

HIGHLAND LAKES CHAPEL MONROVIA, INDIANA

Donald Andrew Minton

APRIL 15, 1992

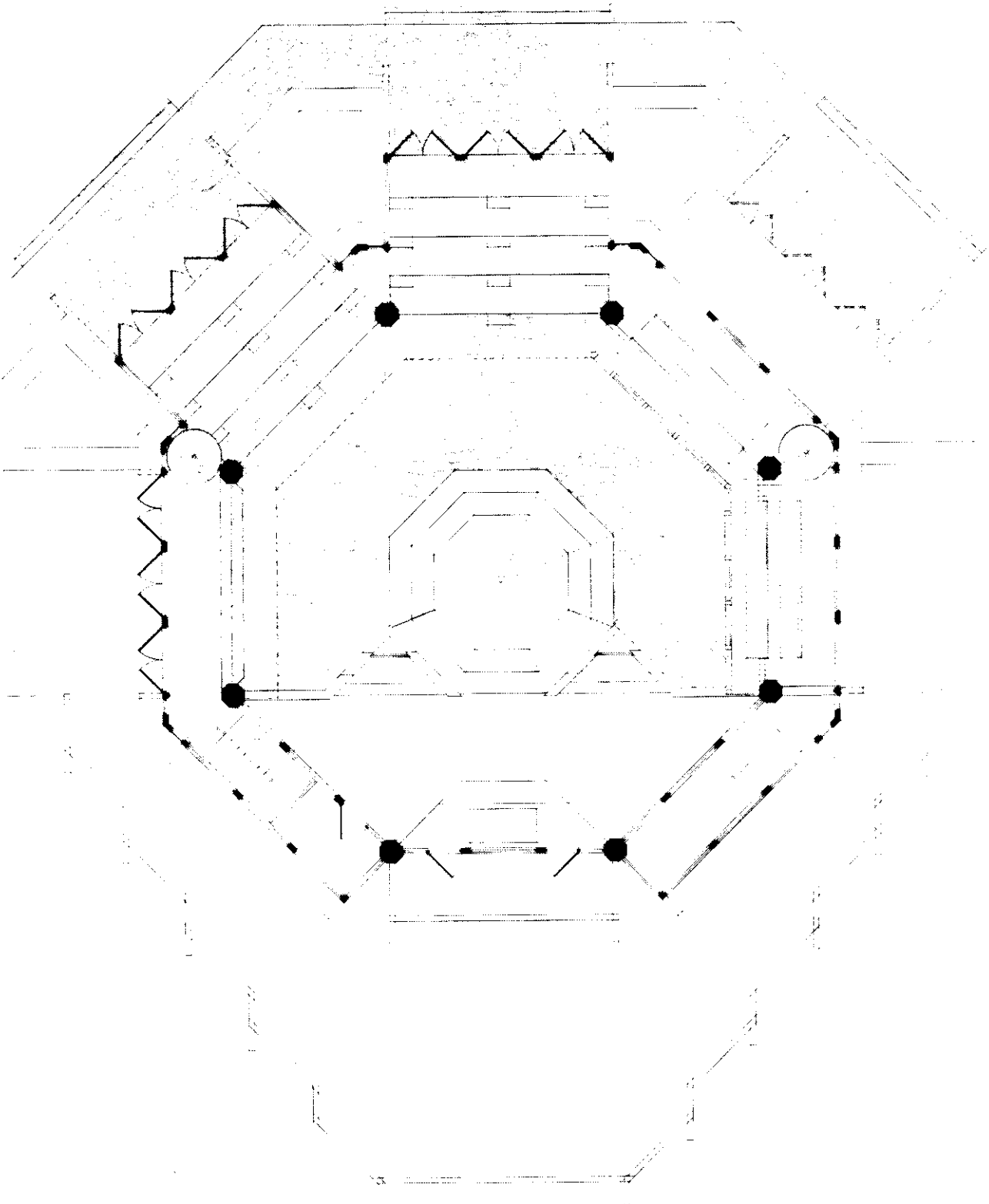

X

ch
re
1
1



56

Donald Andrew Minton

Retreat Chapel for Highland Lakes Camp
and
Retreat Center
Monrovia, Indiana

A Study of "Organic Architecture":
Architecture & Landscape as a Whole

April 1992



Architecture Department
College of Architecture and Planning
Ball State University

Donald Andrew Minton

Retreat Chapel
A Study of "Organic Architecture"

Bachelor of Architecture Degree
Thesis Design

Architectural Design Thesis Committee:

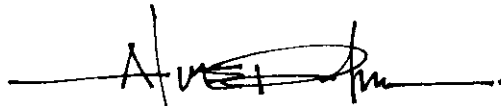

Sonny Palmer
Architectural Design Studio Professor

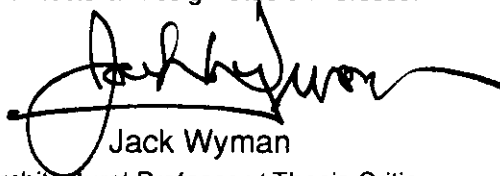

Jack Wyman
Architectural Professor / Thesis Critic

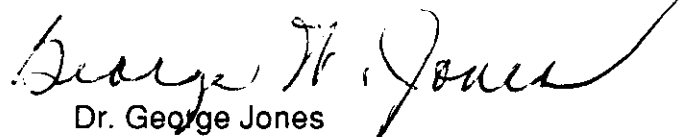

Dr. George Jones
Non-architectural Faculty / Thesis Consultant

Copyright 1992



The production of the information put into this booklet was accomplished with the help of several individuals outside of the thesis committee. I would like to thank the following individuals for their time, energy, and advice which was given to help produce this finished project:

Members of the Highland Lakes Camp Committee:

David Wood

Don Hamlin

Marc Bewley

Bob Hinton

Craig Swofford

Rick Terry

Others who provided valuable information and support:

Teresa Pollock

Family Members

Studio Classmates

Table of Contents

Introduction5
Description6
Thesis7
Research8
Theory Paper10
Programme23
Context34
Methodology38
Design Process39
Initial Ideas41
Plan42
Structure44
Elevation46
Section47
Details48
Final Design50
Model51
Drawings57
Reflection62
Presentation63
Conclusion64
Bibliography65

Introduction

The major emphasis of my thesis is on the strong relationship that can exist between a building and the natural environment. I focused my research on the architects who created their buildings using an "organic" philosophy towards design. The major architects which I researched on this topic were Frank Lloyd Wright, Alvar Aalto, Bruce Goff, and Eruine Fay Jones. The basis of "organic architecture" revolves around the concept that a building is an organism in which all the pieces of it, no matter how small, are integrated in a way that forms a unity of the whole.

The project for my thesis is the design of a chapel for the Highland Lakes Baptist Camp located near Monrovia, Indiana. The final design of the chapel came about through the process of researching existing chapels and combining some of their ideas with the principles used in "organic" design. Originally, I had proposed to design a multi-purpose facility for the camp. This facility was to include the following:

- A worship area for services, conferences, and conventions of around 300 people.
- Indoor and outdoor recreational areas.
- Living and sleeping spaces.
- A dining facility.
- Personal and individual spaces.
- Fellowship areas for small and large groups.

The intent of the camp committee was to construct a large building which would support these functions. My advice to the committee was to divide these functions into three buildings, taking advantage of the beautiful scenery of the site. These three buildings could be constructed in phases as the money became available to finance them. They consisted of a chapel, a combined gymnasium and dining facility, and a series of different sized cottages. The largest extent of my thesis project and research was directed towards the design of the chapel due to time constraints. Conceptual ideas for the designs of the other two phases are included.

Description

Thesis

Since the beginning of time, man has built his spaces / shelter in and around the natural environment. The forms and materials came from the landscape and fit as a part of their surroundings. As technology and knowledge of synthetic materials has increased over time, however, it seems that man has found ways to build his own environment isolated or separate from the influences and context of the natural landscape.

In this project, I set out to answer certain questions about the relationship of the built environment and the natural environment. These questions consisted of the following:

Does form follow function?

The design for the chapel was intended to provide a feeling of openness and serenity. Although its main focus was to provide an indoor space large enough to accommodate a certain number of people for worshipping together, the design of the pieces, form, and structure of the chapel were guided by the desire to create a space which replicated the qualities of its forested site.

How does nature define / identify space, and can it be replicated in architecture?

How do lighting, enclosure, cover, materials, texture, color, and movement in architecture compare to that of the natural environment?

When walking through the trees, thousands of branches and leaves create patterns of lines, voids, shades, and shadows. As the sun moves throughout the day, new patterns are created by the direction of the light moving around and through the natural forms. I attempted to create a similar effect in the design of the chapel. Like Fay Jones' Thorncrown and Cooper chapels, I chose to express the structure of the building on both the interior and exterior. My intent was to try to replicate the repeating vertical lines of the trees and their interconnecting branches above.

I chose to use the natural materials of wood and stone for the major pieces of the building to fit in the context of the site. Stone is used as the flooring material to provide a transition between the interior and exterior of the building. The surface on the inside of the lower floor is stone and mortar. As you move to the outside, the floor changes to stone with grass growing between the individual pieces. The stones then dissolve as you move up the steps, leaving only the grass of the environment. Wood was used throughout the building to provide a unity between all the individual parts. I used natural materials to try to help bring the exterior qualities of the site to the inside of the building.

The original lighting concept of the chapel was to place windows all around the perimeter of the building between the structural frame, providing a picturesque view of the site. I decided to close some of the openings with siding to provide insulation during the winter and cut down the cost of the building. Most of the windows are placed within the triangular trusses below the roof forms, bringing the majority of the light from above.

Research

My research for designing the chapel started with the analysis of several different styles of small churches and chapels. I examined the plans, elevations, and volumes of these buildings to see what they had in common and what made them unique from the others. The most significant element within each of the buildings was the altar. It is the area in which the audience focuses its attention. All of these buildings emphasized the altar in some way different from the rest of the other forms. The techniques used were:

- Raising the altar above the level of the floor.
- Using a different texture or material at or behind the altar.
- Illuminating the altar from above, beside, or behind with lights or windows.
- Placing the altar at the center of the space and /or on axis with the aisles.
- Arranging the seating which is directed towards a focal point.

I chose to use a combination of several of these ideas to help emphasize the altar inside of the chapel. The altar space is raised above the main floor and is covered with wood decking instead of stone, emphasizing its difference. The seating is arranged in a semicircular pattern, focusing on the center platform which steps up towards the altar. The major and minor entrances to the chapel are located on axis to direct you towards the center of the space.

The volumetric shapes of these spaces were the most unique thing about the different churches. Most of them were developed using a system of repeated elements and proportions. Whether square, triangle, circle, or rectangle, the pattern was carried throughout the design. The most successful and inspiring ones were Frank Lloyd Wright's Unity Temple, Unitarian Meeting House, and E. Fay Jones' Thorncrown, Cooper, and Marvin L. Leonard chapels.

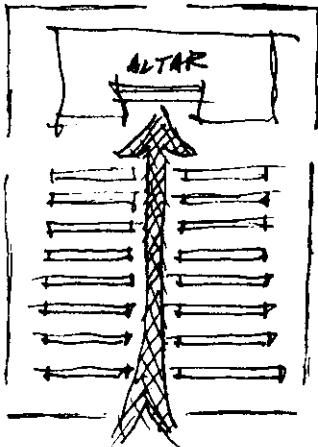

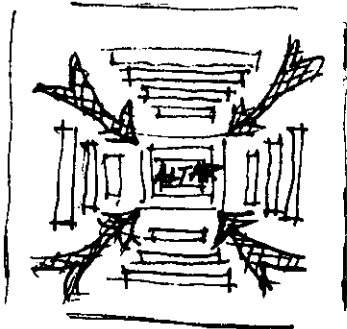

- THE VIEW DOWN THE AISLE(S) ALWAYS FOCUS(ES) ON THE ALTAR. THE INDIVIDUAL'S ATTENTION IS IMMEDIATELY CAPTURED UPON ENTERING THE SPACE.

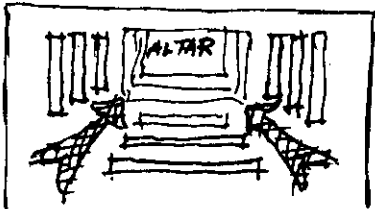

- THE SEATING IN EACH EXAMPLE USE EITHER BENCHES OR PEWS. THE FLEXIBILITY OF THE SEATING ARRANGEMENT IS NOT VERY GOOD.

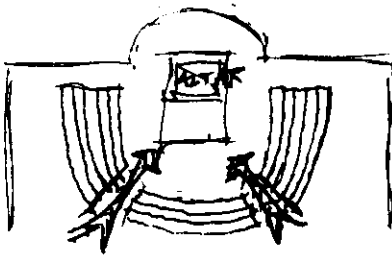



Theory Paper

The following pages consist of a research paper which investigates some of the strengths of communication through architecture. This paper specifically focuses on three of the "organic" architects and some of their constructed masterpieces.

Donald Andrew Minton

ARCHITECTURE AS COMMUNICATION
Communicating Natural Ideas through Design

When we look at the natural environment and examine the forms and spaces it creates, we begin to notice that similar geometrical patterns and mathematical proportions are repeated. These patterns and proportions develop rhythms of space and form from the small scale of a snowflake to the large scale of a mountain range, creating a harmony between the individual pieces and their relationship to the whole. For example, each snowflake is unique from all the rest in its size, shape, and pattern; however, the way in which they are formed and their chemical composition are exactly the same. When millions of them fall upon one another and bond together on the ground, they become as one. Each mountain, in similar fashion to the snowflake, is unique to all other mountains. Whether they are volcanic or solid rock, are on land or below the sea, have slopes lined with trees or tops capped with snow, they each stand alone as individuals, but belong together as parts of a larger whole.

The natural environment creates spaces which provide shelter and comfort, food and water, safety and danger, and life and death. Each element of nature serves a particular function which keeps all things in balance with one another. Architecture is an invention designed by man which is used to create new environment of differing scales to provide particular needs, desires, emotions, and other functions. Several architects of the twentieth century believed that architecture should be created by using the patterns and geometries which are found in nature. They believed strongly that architecture, like nature, is an "organic" thing. Organic architecture seeks to create spaces and forms which tie the building and its pieces together with its surrounding landscape. This type of approach to designing architecture is what Lesnikowski calls "contextualism." He states that contextualism "bridges the gap between artistic feelings and human qualities and needs."¹

The contextualist architects create spaces which communicate and replicate the qualities of their natural surrounding and human feelings. The works of Frank Lloyd Wright, Alvar Aalto, and E. Fay Jones are prime examples of spaces which were created to communicate the ideas of organic architecture. Each of these three architects use unique approaches to communicate this very similar concept of architecture as being a living organism. They each held the philosophy that a building is made of an integration of unique, individual pieces which work together as a group to create one unified whole.

Frank Lloyd Wright's major works were mostly designed and constructed in the early twentieth century. His houses provide the best examples of the ideas which he believed were the ideals of organic architecture. These houses were created using the concept of the home as the center of family life. In the Prairie Style houses such as the Robie House and the Darwin Martin House, the fireplace was placed in the middle of the house as a symbol of warmth, fire, and life. The rest of the forms and spaces in these houses moved outward from this center towards

the exterior, creating a transition of elements between indoor and outdoor spaces.²

He communicated a balance between the interior and exterior spaces using several techniques. The houses were low to the ground and reached out to the exterior with horizontal bands of windows, wide projecting eaves, shallow sloped roofs, and exterior porches and terraces. The low building profile made the houses appear to hug the ground. He used masonry at the base of the houses to give them more visual weight. The bands of windows around the house opened the inside to the exterior, allowing light to filter into the interior spaces. Their placement directly below the eaves of the roof gave the appearance of the eaves to be floating in space. He used this technique to communicate the similar feeling of the light weight branches and leaves of the trees which spread out, providing shade and shelter below. The covered porches and terraces of his houses provided transitional spaces between the enclosed interior and the open exterior.³

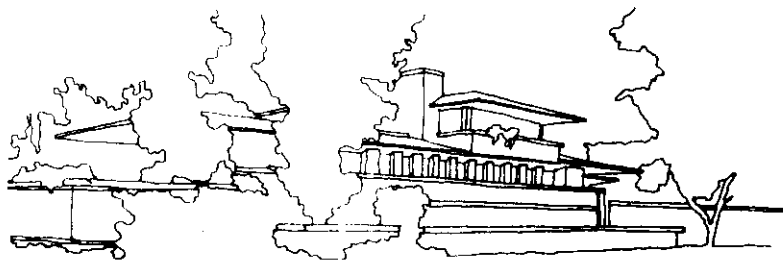

Wright designed his houses with cross-axial, asymmetrical plans. He used this asymmetry to manipulate volumes of space, creating physical and visual movement which does not exist in formal, symmetrical pieces. The interwoven interiors of the houses express the uniqueness of each space, view, and experience which one finds in nature. He believed that each of these spaces should communicate a different feeling or emotion, expressing its functional purpose.⁴ The cross-axial plans of the houses created visual movement in all directions, radiating from the hearth, the center of the house. The fireplace and chimney of his houses was the only vertical element, symbolizing its importance as the "heart" of the built organism. He explains this idea when he states:

Organic architecture sees shelter not only as a quality of space but of spirit, and the prime factor in any concept of building man into his environment as a legitimate feature of it.⁵



His houses were designed to communicate the spirit of family and comfort. He strived to bring a close relationship between the building, its users, and the site. The Kaufmann House, also known as Falling Water, is an excellent example of Wright's ability to place a building in a harmonious relationship with its natural setting. Falling Water is located in a forested area in Pennsylvania. The house rests on the side of a large rock with a stream running across it. The structure of the house is made of large horizontal slabs of concrete which cantilever outwards from a large, vertical, stone chimney in a cross-axial pattern, replicating the layering of the rocks upon which it rests. Although concrete is a man-made material, Wright's treatment of it by using a rough texture and deep thickness creates a strong relationship with the rocks below. The low ceilings and mostly transparent walls direct the viewer's orientation from the inside to the outside.⁶

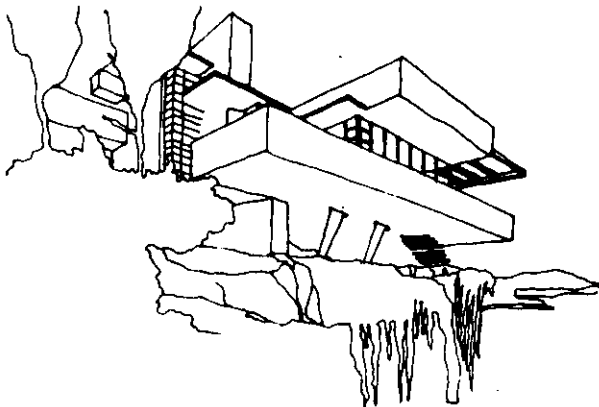
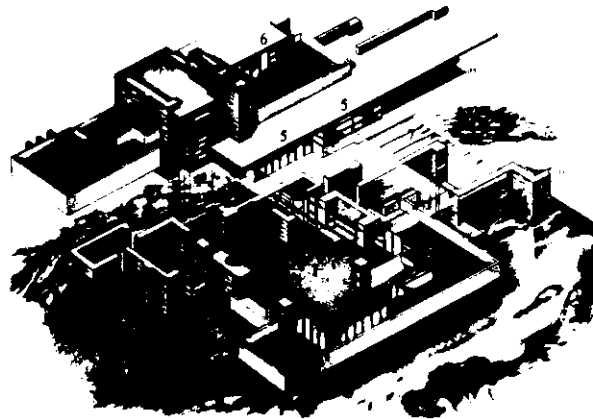

Wright did not limit his organic architecture to be constructed of natural materials alone. When he did use synthetic or man-made materials, however, he believed that they should be expressive of their properties. He expressed the structural properties of steel in the columns supporting the concrete slabs at Falling Water. The thin steel pieces communicate the extreme strength of the material. Because the steel was used to express its natural qualities, it does not take away from the unity of the whole. The concrete and steel work together, forming a skeleton for the rest of the body to grow in and around.⁷

Wright's design of Unity Temple in Chicago, Illinois is very different from his houses. It is not asymmetrical, low to the ground, and directed to the exterior; but it is still organic in Wright's sense of the word. The church is still intended to communicate a feeling of many different parts uniting to form a whole. The outside of the building consists of three massive, square, concrete forms. The top opens up and allows light in through windows and skylights. The massive concrete walls consist of a rough texture, scaling them down to a more human size. The center form is smaller in size, drawing you towards the entrance.⁹

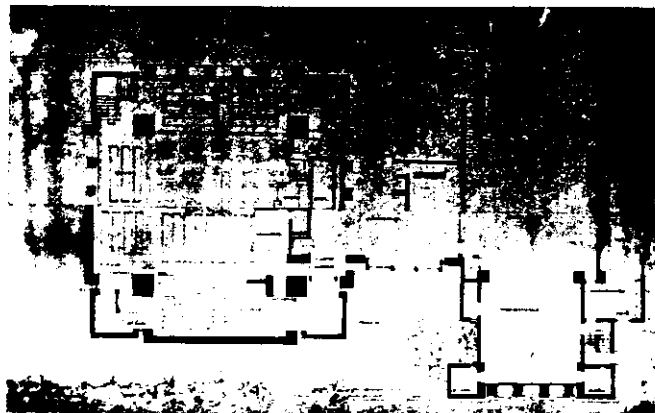
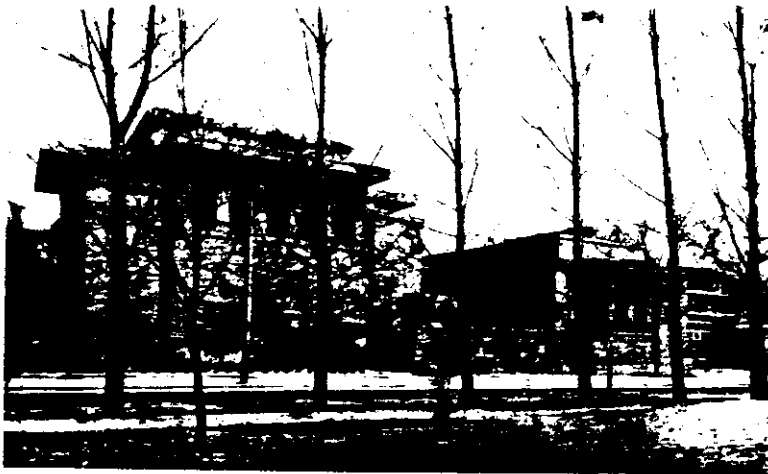

The feeling of unity and closeness is created by the large form containing the sanctuary. As you enter from the low ceiling space of the entry into the high and short space of the sanctuary, your eyes are directed upwards. The light entering through the massive walls and ceiling provides a sense of the exterior piercing its way to the interior. All of the seating is placed tightly together facing the altar, creating a feeling of closeness, togetherness, and unity.

Alvar Aalto's organic ideals towards architecture take an extremely functionalistic approach. Aalto's designs center on the concept of form following function. He creates individual spaces which are unique, dynamic, irregular, and unbalanced. Although each space serves a unique function and has a unique form, they are connected together in ways which make them complement each other.⁹

In his design for the Mount Angel Library in Oregon, Aalto derives the form of the library from the function. The plan of the library is arranged in a fan-like pattern which radiates from the central circulation desk. This communicates the importance of the desk as the control center of the library. The shelves of books are lined up on axis with the circulation desk, allowing the employees to view the entire selection of books.¹⁰

The fan shape is created by Aalto using a triangular shape and repeating a similar but different one next to it. Each of the four radiating pieces of the library contain the same language while providing a unique space to all the rest. The facade of the fan-shaped spaces allows light to enter from different angles throughout the day. Small, private, reading rooms are placed at the perimeter of the fan shape, providing a view out over the inclined slope upon which the building rests.

Aalto addresses the sloped site by building the three story structure into the slope, presenting a one story facade on the flat ground and a projecting three story facade on the sloped side. The interior of the building opens up near the center. This allows the light from the skylights above the circulation desk to penetrate into the lower level. It also allows a greater view of the library from the central desk. Aalto placed a counter with stools around the perimeter of the opening to the lower floors, providing additional spaces for reading and studying.

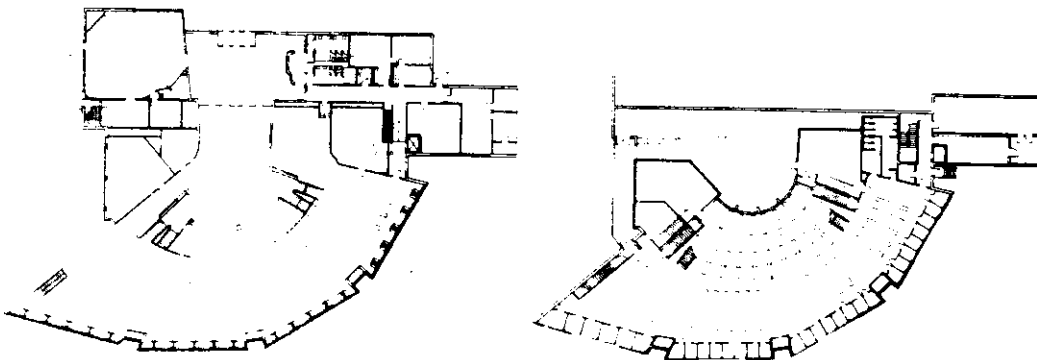

Aalto controlled the movement of sunlight into the space very carefully to prevent the books from becoming damaged from direct light. The top story windows are placed in a horizontal band at the top of the wall to allow light to move over the shelves of books into the central space. The walls and ceilings are painted white to allow the light to bounce around and soften the feeling of the inside. The stacks of books are arranged perpendicular to the windows which prevents light from falling directly on the books themselves.

The staircases are located at the end of each side of the opened space. Everything in the library is organized to support the function of the building. Most of the library spaces can be easily viewed from the central space, allowing ease of movement through the building to the desired destination point. The design of the seating, light fixtures, railings, counters, shelves, and tables serve the purpose of providing a specific function as well as creating visual elements which complement the aesthetic design. The Mount Angel Library communicates to the user an openness to a vast amount of information contained in the thousands of volumes of books.

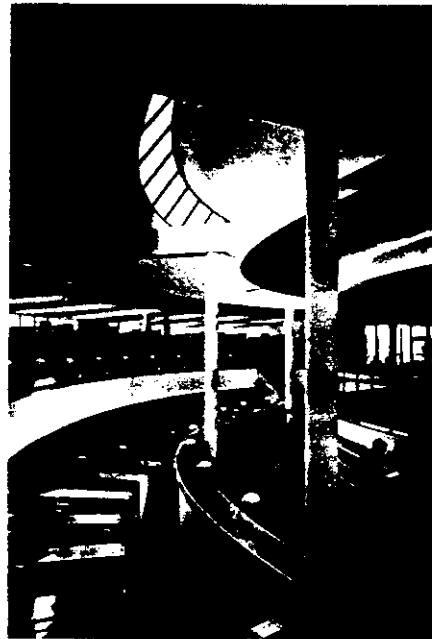
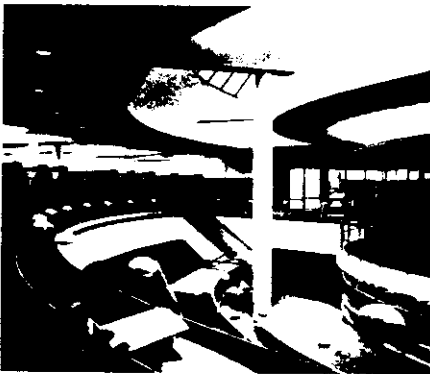
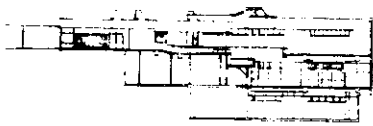

The Villa Mairea was designed by Aalto as a relaxing, retreat home for a wealthy client. The concepts used in the design of this home are very similar to the ones of Wright's "Prairie Style" homes. Each piece of the house was designed using very different shapes, volumes, materials, and textures. The house is arranged in an L shaped plan on the first floor. Extending from the long axis of the L is a terrace which connects to a sauna. The form of the house provides a physical border for the kidney shaped pool along side of the sauna. The main part of the house is divided into several rooms, each containing a floor material of wood, stone, or tile. The elevation of the house has projecting porches, terraces, and windows all around the perimeter. These forms open the building up to the exterior and reach out to points of the site. The pieces of the building are very random and irregular in their forms and connections, communicating a natural feeling. Although many of the pieces are different, Aalto repeats certain elements in more than one space. Vertical wood strips are used as siding for the second floor studio facade, railing on the second floor terrace, and railing for the interior staircase. The same wood strips are also used for the ceiling of the front porch, the deck for the outdoor pool, and the floor of the multipurpose room. These strips are placed at irregular intervals to create a unique spacial quality in each place they are used.¹¹

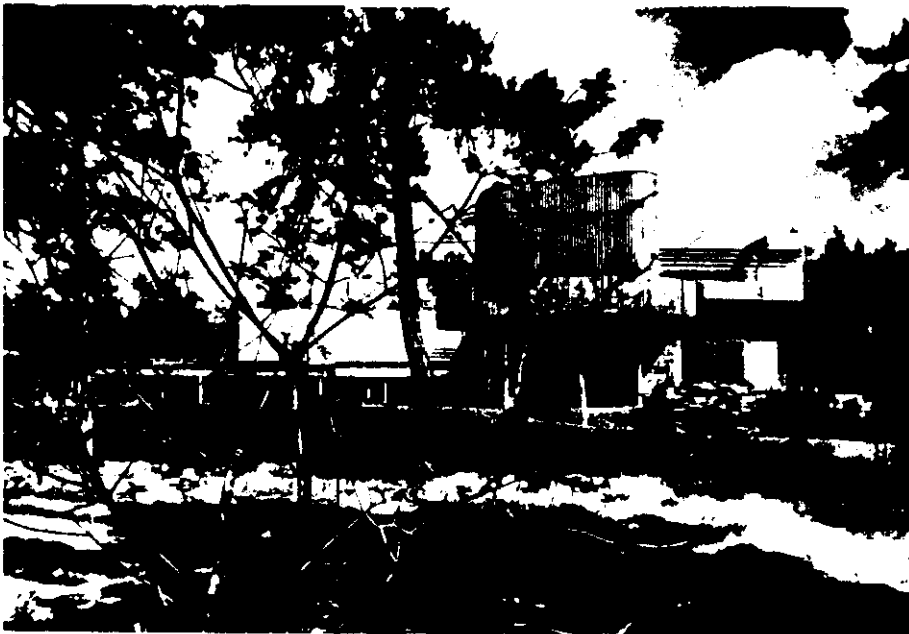

Natural materials of rough and smooth stone are used for flooring and wall material. The exterior fireplace is formed into the wall out of rough stone and has stair steps projecting out of the wall above, providing movement to the upper level. These stairs lead to the grass covered roof over the walkway. This appears to make part of the house grow into the site. The overall organization of the building provides a variety of interior spaces which have controlled openings and views to the site. The irregularity of the forms and surfaces of the house creates a variety of shades and shadows, harmonious to those created by the natural elements of trees, rocks, and hills on the site.¹²

The influence of Wright's emphasis on the honest use of materials, the harmony created between a building and its site, and the importance of each piece as an integral part of the whole can be seen in the work of the present day architect, E. Fay Jones. A one time student of Wright, E. Fay Jones designed several chapels which emphasize and communicate the ideas of rhythm, harmony, and the integration of structure and space. Jones achieves the same organic feeling as Wright's house designs without the use of asymmetry. Both Thorncrown Chapel and Cooper Chapel are placed within the setting of tall, thin trees. Each chapel is designed on a symmetrical plan and repeats specific proportions in plan, section, and elevation. These chapels are almost completely covered in glass except for the thin structural members and roof covering.¹³

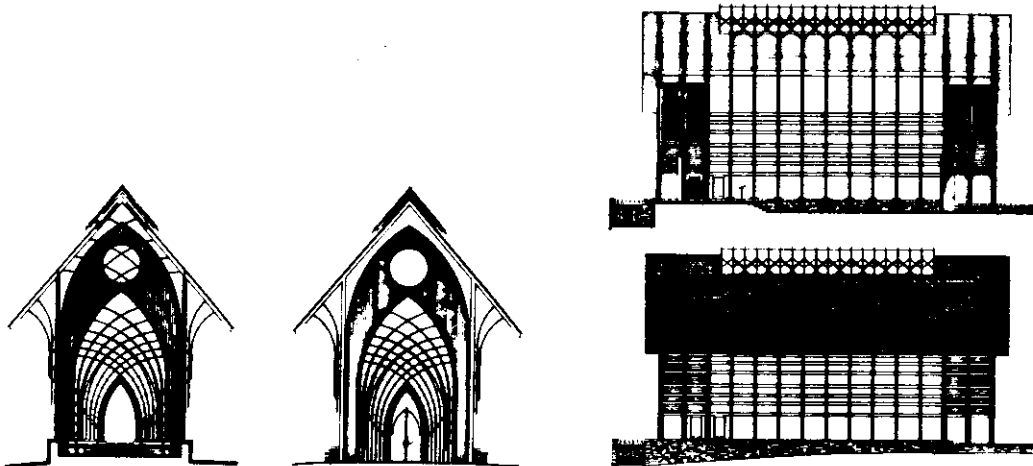

The structure of Thorncrown Chapel is built entirely of 2"x4" and 2"x6" pine members connected together in a modular pattern, forming straight lines of delicate, intersecting pieces. Cooper Chapel uses thin pieces of curved steel to communicate the strength and flexibility of the material. These steel members form Gothic arches all the way through the building. In contrast to the heavy, massive stone walls and columns of the great Gothic cathedrals of Europe, these two chapels use their thin structure to open the walls to the natural surrounding. The structural pieces replicate the trunks and branches of the trees, providing a sense of cover and protection while allowing the sunlight to filter through the space. Jones opens the interiors of these two chapels to the exterior at a much grander scale than most of Wright's work. This openness brings the outside to the inside instead of extending the interior to the exterior.¹⁴

As mentioned earlier in Wright's and Aalto's work, Jones used the manipulation of forms and careful treatment of the materials of each piece as the creation of the ornamentation. Ornament was not to be added as something extra to spice up the design; it was designed as the intricate connections and individual pieces which were to supplement the whole. In Jones' chapels, specific, detailed treatment was used to design the light fixtures, doors, pews, lecterns, and structural connectors. This attention to detail at every scale visually ties the individual parts of the building together to form a singular unit.¹⁵

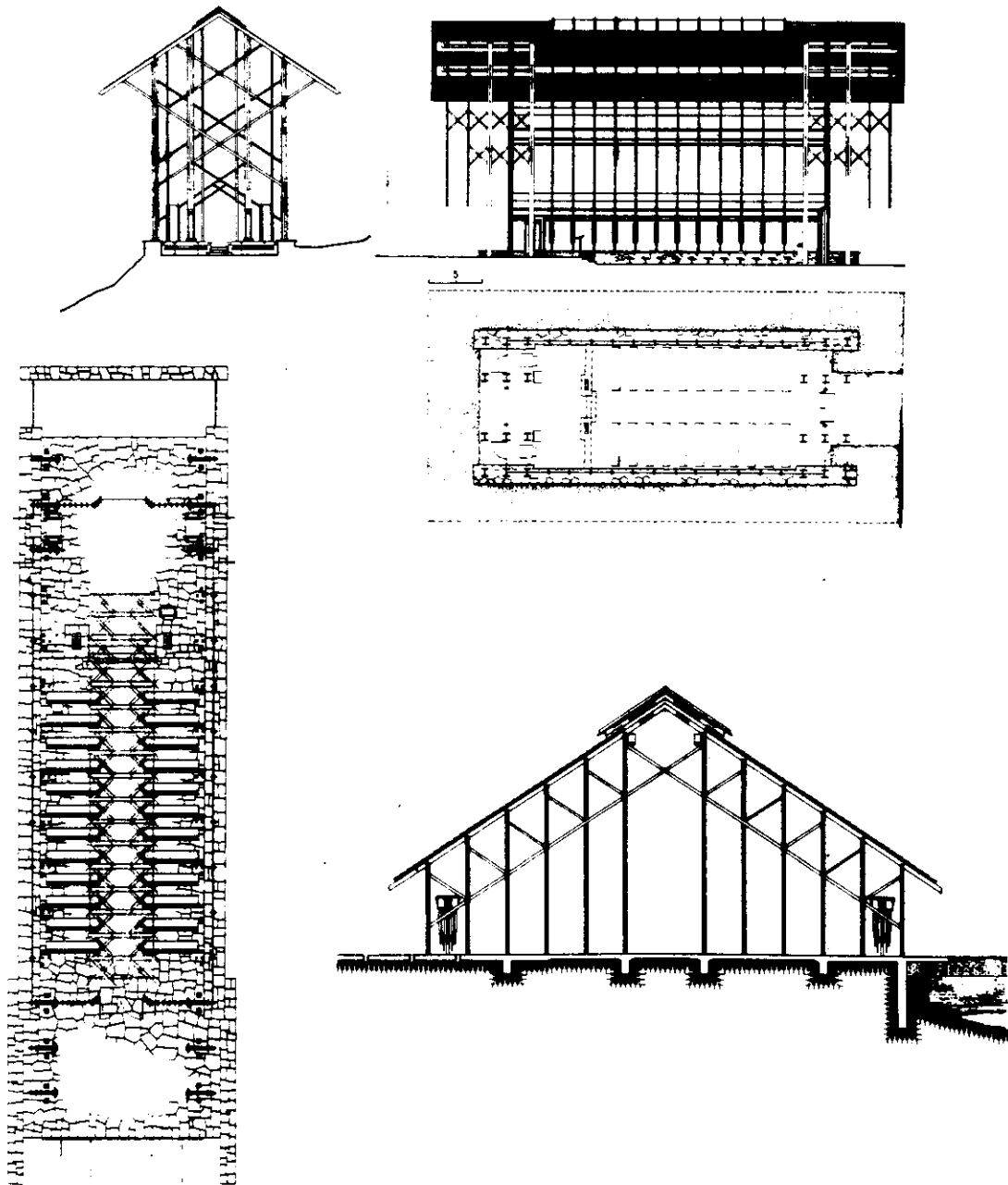

Another philosophy which E. Fay Jones communicates is that the spaces of his buildings unite form and function into one. The Crosby Pavilion in Picayune, Mississippi was designed as an outdoor area for dances, picnics, parties, and festivals. The form is much like his chapels. Made of intersecting rows of wood members, this building is completely open around the perimeter and covered with wood decking and glass skylights. The form functions as a covering, while being completely outdoors. The roof breaks apart and reaches outward to the landscape with only the exposed structural members left on the ends. The lights are made of layered pieces of wood raised slightly off of the ground. At night, the light shines onto the branchlike forms of the structure above, creating a unique space within the forest of natural and man-made trees.¹⁶

Communication through architecture is expressed in many different ways. Wright, Aalto, and Jones each communicated similar ideas of organic architecture through their work; however, their approaches to this type of thinking are each unique. Each of these three architects of the twentieth century manipulated the forms and volumes of their buildings to communicate a strong relationship between the building, the human scale, and the natural surroundings. This was accomplished through the simplicity of ornamentation, the control of light and its movement, the expression of materials, the repetition of similar geometries, and the integration of all the building's pieces.

End Notes

¹ Lesnikowski, p. 213.

² Hollingsworth, pp.17-19.

³ Scully, pp. 17-19.

⁴ Lesnikowski, p. 218-220.

⁵ Lesnikowski, p. 219.

⁶ Hollingsworth, pp. 90-93.

⁷ "World Atlas of Architecture.", p.378.

⁸ Scully, p. 20.

⁹ Lesnikowski, p. 231.

¹⁰ Fleig, pp. 131-132.

¹¹ Frampton, p. 199.

¹² Pearson, pp. 172-175.

¹³ Cordes, pp. 52-57.

¹⁴ Ivy, pp. 82-89.

¹⁵ Cordes, pp. 52-57.

¹⁶ Douglas, pp. 104-109.

Bibliography

- Cordes, Karen. "Encore Delivered with Strength and Delicacy." Architecture. v. 77. Oct. 1988. pp. 52-57.
- Dillon, David. "House of Spirit." Architecture. v. 80. Mar. 1991. pp. 94-97.
- Douglas, William Lake. "The Poetics of Revealed Construction." Progressive Architecture. v. 68. May 1987. pp. 104-109.
- Fleig, Karl. "Alvar Aalto." Imprenta Juvenil, S. A. Barcelona. 1985. pp. 131-132, 209-214.
- Frampton, Kenneth. "Modern Architecture." Ch. 3. 'Frank Lloyd Wright and the Myth of the Prairie 1890-1916.' pp. 57-63. Ch. 22. 'Alvar Aalto and the Nordic Tradition.' pp. 192-202.
- Gandee, Charles K. "A Wayfarer's Chapel by Fay Jones." Architectural Record. v. 169. Mar. 1981. pp. 88-93.
- Hollingsworth, Mary. "Architecture of the 20th Century." Exeter Books. New York 1988. pp. 16-19, 33, 87-93, 131-133.
- Ivy, Jr., Robert A. "Solid Gold." Architecture. v. 80. Mar. 1990. pp. 82-89.
- Lesnikowski, Wojciech G. "Rationalism and Romanticism in Architecture." Ch. 10. 'The Theory of Organic Architecture.' pp. 212-235.
- Pearson, Paul David. "Alvar Aalto and the International Style." Whitney Library of Design. New York. 1978.
- Roth, Leland M. "A Concise History of American Architecture." Harper and Row, Publishers, Inc. New York. 1980. pp. 200-210.
- Scully, Jr., Vincent. "Frank Lloyd Wright: Masters of World Architecture." George Braziller, Inc. New York. 1990.
- "The World Atlas of Architecture." Portland House. New York. 1988. pp. 378-379.

Programme

Background

Highland Lakes Camp and Retreat Center was created by Camp Planner, Charles C. Scott of Raleigh, North Carolina in 1972. Parts of his master plan were approved by the State Convention of Baptists in Indiana and constructed at the site near Monrovia. The intention of the facility is to promote the continued education and spiritual development of the Indiana Southern Baptists by providing a facility which: 1) was in an outdoor setting, away from everyday people, 2) utilized the comforts of nature to express God's power and beauty, and 3) provided buildings to accommodate the individual's basic needs.

In 1989, Urban Planner, Scott Truex, developed an updated master plan to the camp, proposing several different zones of activities. His plan recommended the development of three lakes to be located on the camp property. An earth dam would be necessary to create the proposed lakes. The possibility of forming one or more lakes is still being researched at the present time. The seven zones proposed in the plan were:

- *Worship and Praise Area
- *Group Camping Area
- *Lodge / Conference Center
- *Natural Areas
- *Recreation Area
- *Rustic Camping Area
- *RV Hook-up Area

Scope

This program defines the current objectives of the Highland Lakes Camp Committee. It addresses the recommended space requirements and design criteria for the proposed expansion of the camp's existing facilities. This booklet is intended to provide a completed package of information to serve as a guide for the designer(s), if the committee decides to continue with their plans of further camp development.

Organization

The Highland Lakes Camp and Retreat Center has several different types of facilities to accommodate its users. The Administrative and Support Facility, located at the front entrance of the camp, provides the housing, storage, and workspace for the camp maintenance manager and his family members. The Group Retreat Area consists of several small cabins with the separate functions of sleeping, dining, fellowship, and worship. These cabins can accommodate small groups of individuals throughout the year. The Rustic Retreat Area is a separate section devoted to tent camping. It is mostly used during the warm months of the year. The camp has a swimming pool for water sports, a picnic area for daytime activities, and an outdoor basketball court.

The Highland Lakes Camp Committee is a group of individuals who represent the State Convention of Baptists in Indiana. They are elected to make the decisions on the growth, maintenance, and development of the camp. The committee consists of seven members at the present time. They are David Wood (chairman), Don Hamlin (camp manager), Dr. George Jones, Marc Bewley, Bob

Objectives

The current objectives of the Highland Lakes Committee are:

*to establish a proposal for the development of:

- (1) a sleeping facility for couples and families,
- (2) a combined chapel and dining facility,
- (3) indoor and outdoor recreation areas.

*to keep the impact of building on the camp's natural environment to a minimum.

*to keep the cost of materials for construction around \$300, 000.

*to cut down labor costs by the use of volunteers.

*to provide handicapped accessibility to common areas.

*to break down the construction of newly proposed facilities into three phases, allowing construction when the money becomes available:

Phase I => Combined Chapel and Dining Facility

Phase II => Family Sleeping Spaces (with the possibility of separated dining facility to accommodate entire camp.)

Phase III => Indoor / Outdoor Recreation Area

*to create an image which provides a "sense of belonging" to all ages and groups of individuals using the camp facilities.

Chapel

USERS

Teenage youth groups.
Children 9 years and older.
Adults and family members.
300 people or less.

ACTIVITIES

Worship service (singing & lectures).
Small discussion groups.
Conventions, plays, musical performances,
and movies.

TIME OF USE

Sunrise through noon.
Early evening.
Afternoon.

LIGHTING

Natural lighting.
20 to 75 footcandles.
50 footcandles at the pulpit.
Indirect artificial lighting.

ACOUSTICS

Narrow plan with high room volume.
Wall and ceiling made of sound-reflecting
materials for a high reverberation time.
Pulpit raised above the seating.
250 to 300 cubic feet per person.

THERMAL

Comfortable ambient temperature from
72 and 74 degrees.
Cooler than the exterior in the summer
and warmer than the exterior in the
winter.
Heating and airconditioning.
Continuous air circulation at a moderate
speed.

VIEWS

Seating facing towards the lake.
View from platform should be able to
see every seat.

ADJACENT SPACES

Entrance / Lobby.
Visitor Bedroom / Office.

AUXILIARY SPACES

Seating storage.

EQUIPMENT

Movable seating for 300 or less.
Altar / Stage / Platform.
Podium / Pulpit.
Choir seating (10 to 20 seats).
Fireplace.

DESIGN CRITERIA

The design should incorporate the beauty
of the natural surroundings to enhance
the spiritual experience of the space.
Glare from natural light into the seating
area should be prevented with shading
devices.
The space should be able to divide with
partitions into several smaller sections
to be used for smaller discussion groups.

Dining Hall

USERS

Teenage youth groups.
Children 9 years and older.
Adults and family members.
300 people or less.

ACTIVITIES

Eating & dining.
Meetings.
Fellowship.
Reading, Writing, & Studying.

TIME OF USE

Morning (breakfast), noon (lunch), & early evening (dinner).
Afternoon.
Evening.

LIGHTING

Natural light.
General artificial lighting.
Task lighting over serving counter.
10 to 30 footcandles.

ACOUSTICS

Building surfaces should be of sound absorbing materials.
Sound should be kept from filtering into other areas.

THERMAL

68 to 72 degrees.
Continuous air circulation.
Heating and airconditioning.

VIEWS

Desire for most seats to have a view looking outdoors.
A direct view into the kitchen should be avoided.
Possibility of viewing chapel area.

ADJACENT SPACES

Kitchen.
Entrance / Lobby.

AUXILIARY SPACES

Table & seat storage.

EQUIPMENT

Tables & seating for 300.
Serving counter.

DESIGN CRITERIA

The floor should be made of an easily cleaned material in case of spills.
Rectangular tables which conserve wasted space should be used.
The possibility of combining parts of the dining and chapel may exist in order to conserve space.
The image must not come across as being institutional.
A comfortable and casual dining atmosphere is desired.

Kitchen

USERS

Teenage youth groups.
Children 9 years and older.
Adults and family members.
Camp cooks.

ACTIVITIES

Cooking.
Dish washing.
Food preparation.
Food storage (dry & refrigerated).
Serving.

TIME OF USE

Morning (breakfast), noon (lunch), and
early evening (dinner).

LIGHTING

General and task lighting.
70 footcandles.

ACOUSTICS

Sound-absorbing wall materials.
Hard, sound-reflecting ceiling.

THERMAL

65 to 70 degrees.
Good ventilation over stove.
to expel excess heat.
Heating and airconditioning.

VIEWS

A partial view into the serving area
is desirable.

ADJACENT SPACES

Dining Hall.

AUXILIARY SPACES

Food storage.
Temporary garbage storage.

EQUIPMENT

Sink & garbage disposal.
Refrigerator.
Freezer.
Oven.
Preparation counter.
Food warmers.
Serving counter.
Storage cabinets.

DESIGN CRITERIA

Traffic through the kitchen should be
limited.
Equipment and building surfaces should be
easily cleaned.
Built-in storage for dry foods is needed.
Serving counter should allow access to
both sides by individuals who are dining.
Materials and design should be in
harmony with those of the dining area.

Lobby / Entrance

USERS

Teenage youth groups.
Children 9 years and older.
Adults and family members.
50 people or less.
Visitors.

ACTIVITIES

Arrivals and departures.
Greetings and welcoming.
Check-in and check-out.
Fellowship.

TIME OF USE

24 hours.

LIGHTING

Natural light.
General lighting.
15 - 30 footcandles.

ACOUSTICS

Walls and ceiling to be made of
sound absorbing material.

THERMAL

68 to 72 degrees.
Heating and airconditioning.

VIEWS

Reception area should have view of
the exterior drive-up area.
Parking area should be shielded from
the view from the entrance.

ADJACENT SPACES

Chapel.
Dining Hall.
Bedroom corridors.

AUXILIARY SPACES

Check-in and message counter.

EQUIPMENT

Counter.
Desk & chair.
Storage cabinets.
Mailboxes.
Chair.
Lounge seating for 10 to 20 people.

DESIGN CRITERIA

The reception area should be open and
located next to the front entrance doors.
A covered drive-up area is needed for
individuals to unload their belongings.
The check-in counter should have
message boxes for each room.
A comfortable lounge type of atmosphere
with seating for small group
conversation is desirable.
The design of this area should have a
"welcoming" feeling.
Floor material will need to resist wear
from high amounts of traffic.

Family Bedrooms

USERS

Individuals 9 years and older.
Family members.
Couples.
2 to 4 people.

ACTIVITIES

Sleeping.
Reading.
Private Conversation.
Personal Meditation.

TIME OF USE

Late evening hours.
24 hours.

LIGHTING

General lighting.
Task lighting for reading.
30 footcandles.
(20 footcandles in the corridors).

ACOUSTICS

Minimum sound intrusion.
Use of sound absorbing materials
on walls, floor, and ceiling.
Provides atmosphere for quiet
conversation.

THERMAL

73 to 75 degrees.
Heating and airconditioning.
Cooler in the evenings.

VIEWS

A view of the proposed lakes is
desired for every room.

ADJACENT SPACES

Corridor.
Other bedrooms.

AUXILIARY SPACES

Bathroom.

EQUIPMENT

Two double beds.
Chair.
Small reading table.
Large dresser.

DESIGN CRITERIA

Built in storage shelves and hanging bar
should be used to save space.
Room should provide a cozy and relaxing
space for personal time and rest.
Access to an adjacent room.

Gymnasium

USERS

Youth groups.
Individuals 9 years and older.

ACTIVITIES

Basketball.
Tennis.
Volleyball.
Large meetings.
Other hard surface sports.

TIME OF USE

Late morning, afternoon, and early evening.

LIGHTING

100 footcandles.
General lighting.
Natural lighting.

ACOUSTICS

Sound absorbing walls to prevent loud echo.

THERMAL

65 degrees and below.
Ceiling fans to circulate air.
Heavy air flow to expel smell and heat generated from exercising.

VIEWS

None required.

ADJACENT SPACES

None.

AUXILIARY SPACES

Locker rooms.
Storage for equipment.

EQUIPMENT

Two basketball goals.
Volleyball net with stands.
Tennis net with posts.
Seating for 30 persons or more.

DESIGN CRITERIA

The ceiling height should be kept to a minimum to fit in better with the surroundings.
Glare from natural light on playing surface should be avoided.
The area should be somewhat open to the outdoors.
Floor area should be kept to a minimum to conserve costs.

Office / Bedroom

USERS

Visiting pastor / lecturer.

ACTIVITIES

Sleeping.

Personal meditation.

Sermon / lecture preparation.

One on one conversation.

Reading.

TIME OF USE

24 hours.

LIGHTING

General lighting.

Task lighting for reading.

30 footcandles.

ACOUSTICS

Minimum sound intrusion.

Use of sound absorbing materials
on walls, floor, and ceiling.

Provides atmosphere for quiet
conversation.

THERMAL

73 to 75 degrees.

Heating and airconditioning.

Cooler in the evenings.

VIEWS

A view out towards the proposed
lake is desired.

ADJACENT SPACES

Chapel.

AUXILIARY SPACES

Bathroom.

EQUIPMENT

Single bed.

Desk.

Chair.

Dresser.

DESIGN CRITERIA

This room should provide a private
space for the visitor to prepare for
his / her presentation.

The atmosphere storage requirement
should be the same as that of the family
bedrooms.

The room should be directly accessible to
the pulpit area.

Building Criteria

Function

Chapel, Dining Hall, Kitchen, Entrance / Lobby, Bedrooms, Gymnasium

The new buildings which are being added to the campsite are to increase the useable spaces of the existing buildings and possibly replace them if necessary. The intent is to bring a new image to the camp which is consistent throughout the site in both appearance and character. The new spaces will encourage the individual(s) to participate in his / her spiritual growth. They will provide more modernized accomodations without creating spaces similar to those used in their every day lifestyle. The facility will function as a more complete community environment within its own camp boundaries.

Flexibility

Most of the larger spaces should be flexible enough to be used for a variety of activities for a varying number of people. The spaces should provide an openness to all ages.

Circulation

Circulation space should be kept to a minimum. The chapel should have a circulation pattern which directs the user(s) towards the alter space. If the separate functional spaces are not located within the same building, there should be a physical or visual link between the programatically connected spaces. Individuals should be directed through the lobby space before entering the chapel area.

Economic Efficiency

Quality materials which are easy to clean should be used. The construction techniques should be kept to an appropriate level of simplicity for the possible use of supervised volunteers to help cut down labor costs. Materials should have good insulating qualities for the winter months. The physical dimensions of the buildings should be adaptable to common dimensions of construction materials.

Energy Conservation

Passive solar techniques should be considered. Ventilation of air through the buildings with fans in place of air conditioning may be favorable. The use of fireplaces as a heat source can cut down heating costs as well as providing light and a more "natural" atmosphere. Use of existing camp utilities will make maintenance easier. Consideration of the existing landscape will allow the need for less energy to be used for heating, cooling, and lighting.

Security

Individual bedrooms should have separate locks, at least from the inside of the room. Access to the kitchen area and offices should be kept at a minimum. All storage rooms and containers should be reasonably secured. The public areas should be supervised on a frequent basis.



Exterior Criteria

Colors / Materials

Natural colors such as browns, reds, whites, and grays as well as natural materials such as wood, rock, and stone should be used to give the buildings a stronger connection to the camp's context. Materials should be durable to both the weather and excessive use. Colors and materials should complement each other and their surroundings. They do not necessarily need to be of the same materials as the existing buildings.

Image / Character

The new buildings should each be complementary with one another. The buildings want to each be unique when compared to the typical churches and parklike lodges found around the country. The structure and connections of the materials should express the intentions of the functions within the spaces they define. An image of similar forms and patterns should be created across the camp to visually link all of the buildings and spaces on the site. An overall unity between nature, the participants, and the building is the main goal which is trying to be reached. The character of the spaces should provide inspiration, curiosity, appreciation, and desire for education and growth.

Service

The kitchen area should be accessible to a road surface for easier transportation of food and garbage from the site. The bedrooms will need to be cleaned before new users arrive.

Parking

More parking space must be added to accommodate the proposed expansion of the camp's facilities. It must be kept at a minimum in order to preserve as much of the natural environment as possible. All parking should be kept near the front entrance to the camp away from the main facilities, allowing the individuals using the camp to get as distant as possible from the normal sights and sounds of their everyday lifestyle. Gravel should be used versus hardtop pavement. Vehicular accessibility to the camp facilities should be limited to the camp employees and special guests.

Context

Site Data

The context of the project is in a beautiful, natural setting. The site is located in a wooded area of Morgan County along State Road 39 about 25 miles southwest of downtown Indianapolis. Many small towns are located within a few miles; however, for the most part, the camp is isolated from the outside world. The camp is in an area where the landscape ranges between steeply to slightly sloped hills with elevations between 700 to 910 feet. Only the higher elevations of the camp are used for construction or camping. Because they are some of the highest points in the county, a moderate wind is prevalent throughout most of the year. Most of the forest area is hardwood vegetation, consisting of white oak, American beech, northern red oak, white ash, pin oak, and yellow-poplar. The soil consists of deep gray and black soils on top of sandstone and shale.

Climate Data

The climate of this area consists of four seasonal changes with temperatures ranging from extremely hot (90s) in the summer months to extremely cold (-10s) in the winter.

Average annual temperature	52 degrees F	
Average winter temperature	17 degrees F (low)	34 degrees F (high)
Average summer temperature	63 degrees F (low)	68 degrees F (high)
Average annual precipitation	40 inches	
Average annual snowfall	15 to 30 inches	

The freeze cycle occurs on the average anywhere from October 15th to April 30th. Heavy flooding occurs frequently due to heavy rains and the rapid thaw of the area.

The pictures on the following three pages show a few views of the site as they would appear during the winter months. The buildings shown in some of the photographs are the small cabins which make up the only buildings that are currently on the camp's property, except for the manager's house and maintenance shed near the camp entrance. As you can see, the area is heavily forested with plenty of flat ground for constructing small buildings to fit within the pattern of the trees.





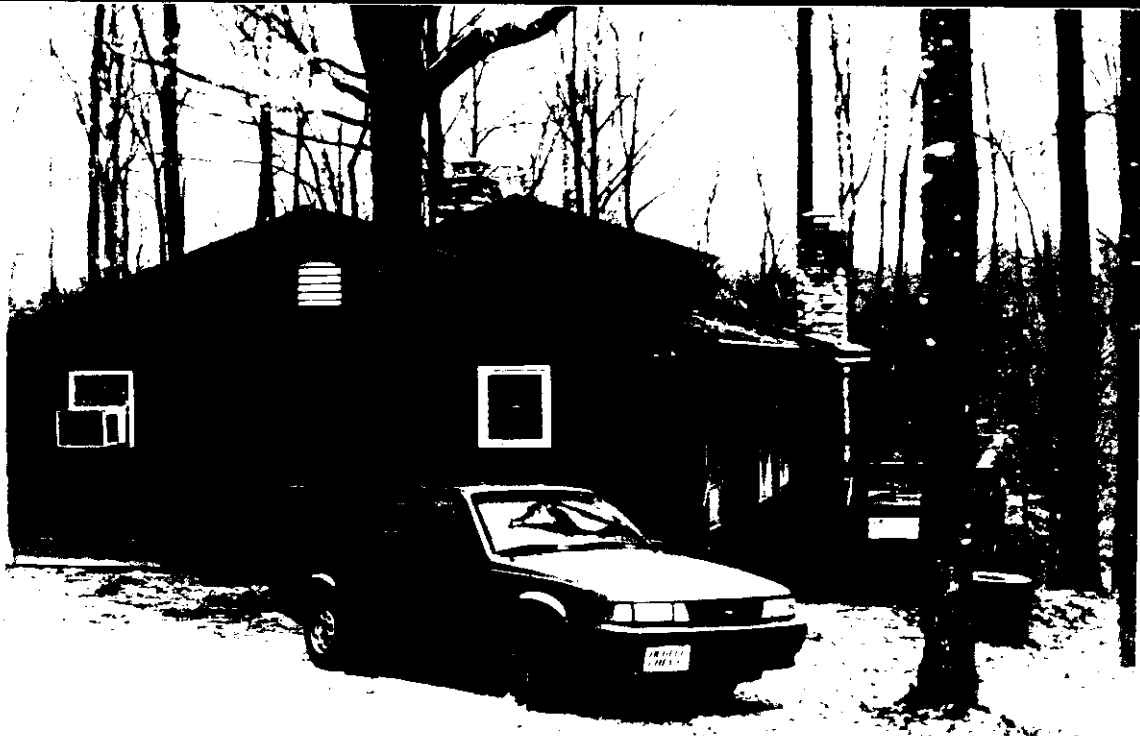

Methodology

Three main factors guided the approach which I took in creating a final solution to the design of my chapel. First of all, I considered the possibility that my design or ideas used in my design might possibly be applied by the camp committee to construct an actual building. This meant that technically, I needed to be very detailed in the design of each piece, dimension, and connection of the building. The structure had to be thought through carefully to allow the best possibility of actually being constructed. Second, several times during the semester I presented my ideas to the camp committee. During these meetings, I attempted to get them to understand why I had changed certain preconceived ideas. I explained to them the reasons that these changes were made, and how the design would benefit from them. At the same time, however, I tried to meet their needs and desires as much as possible without breaking away from the confines of my thesis topic of organic architecture. Third and most important, I attempted to create a design that followed the concepts, created the quality, and applied the techniques used in the churches and chapels designed by the architects in which my research was focused.

Design Process

Initial Ideas

In the early stages of the design, I separated the project into three parts. The first part concentrated on the conceptual design of the individual cottages which were to be used by groups of small families. The second part consisted of the gymnasium and dining facility, and the third was the chapel. Because of time constraints, the first two parts were only partially developed. The rest of my time was devoted to completing a design for the chapel.

Cabins

Since the existing cabins have many beds on each side, they are not private enough for the use of families. My idea was to design a modular bedroom space which could be grouped together with others to create a larger building. I created a pinwheel shaped cabin as the basic model. The sketches shown below communicate how these pieces would fit together. Each cabin would have a tall center piece, containing the bathrooms and all of the mechanical heating and cooling equipment, if desired. Each bedroom space would have a lockable door connecting it to the other bedrooms. These doors could be left open, if a large family needed to use more than one bedroom. The structure would be made of wooden trusses and members. Because all of the plumbing and mechanical systems are isolated in the center of the cabin, the exterior walls could be constructed of doors which framed in between the structural members. This idea allows the cabins to visually open up to the natural surrounding from the interior. Natural cooling from the wind could be used during the summer months. The flexibility of the design provides the possibility of a variety of different sized cabins to be built. It also allows the cabins to fit in and around the trees, limiting the number of them which need to be moved or cut down. The small size creates the opportunity for the camp to build the cabins one at a time as the money becomes available.

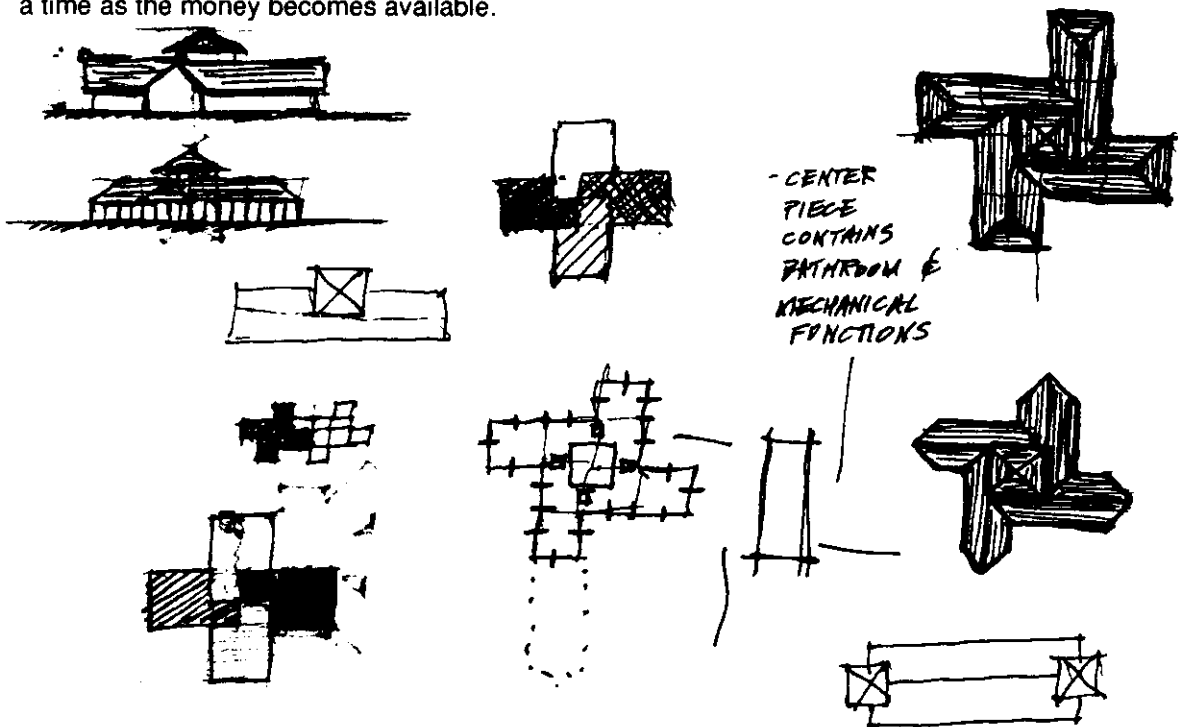

Indoor Recreational Building

The second part of the project was the design for a building which functioned as the combination of a dining hall and gymnasium. I separated these function from the chapel space, because I saw the chapel as being unique from the rest of the other spaces. My design of this building was limited to the conceptual ideas shown below. The main part of the building is the large gymnasium space where sports activities and dining would occur. At the two ends of the long axis of the central space would be a kitchen on one end and a stage at the other.

The building would be located near the front half of the camp with the kitchen nearest the entrance. This would prevent large trucks from coming far into the camp to deliver food and take away trash. Along the long sides of the gym floor would be an outdoor deck to one side and the entrance with small room to the other. The height of the building would be tallest above the gym floor and lower on the sides. The walls along the long sides of the gym would be constructed of doors placed in between the large columns supporting the gym roof. This would allow the building to open up. Clerestory windows would be located around the perimeter of the central space where the walls are higher than the roofline of the surrounding spaces. These windows would bring light into the gym and could be opened for ventilation. The building could be built into the side of a slope on the site with the deck facing down the slope. This would bring the height of the building down and make it appear to visually tie itself to the ground.

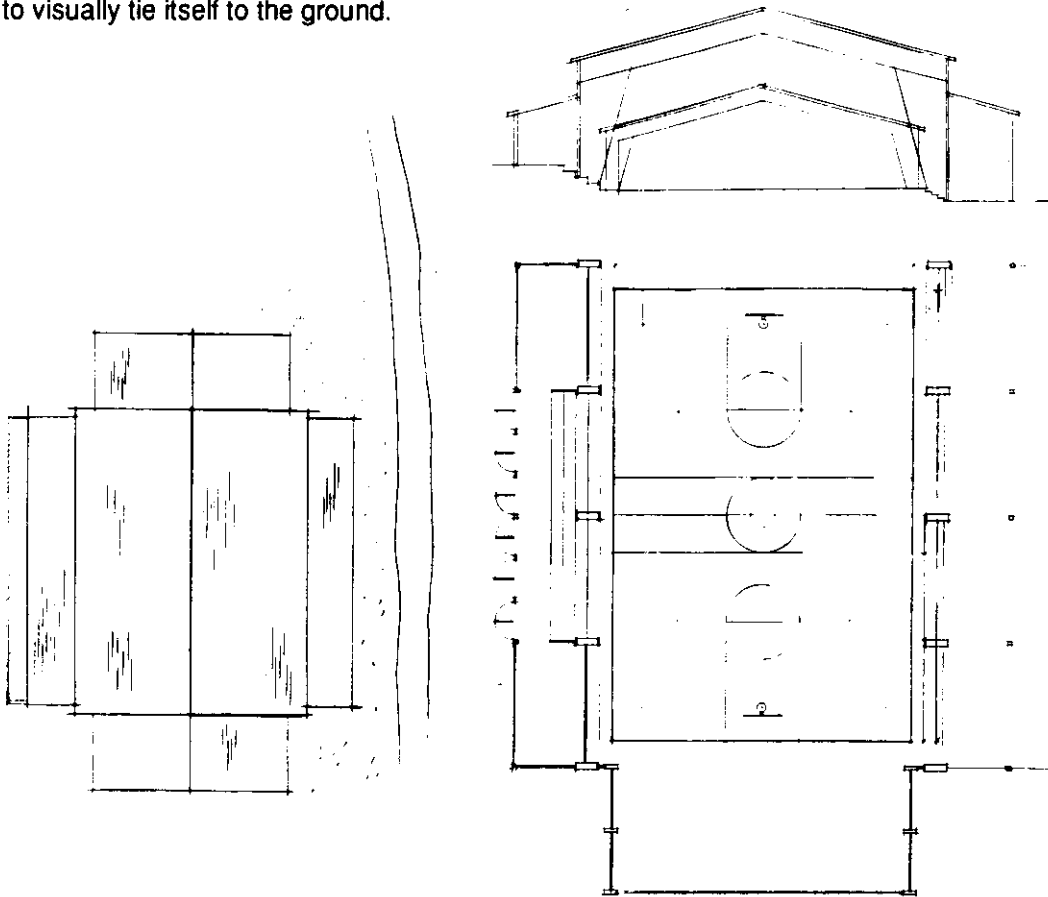

Chapel Plan

The design for the chapel started out with some of the similar ideas used in the concept of the cabins and the gymnasium. I began with the concept of the Greek cross as the form of the plan. This form is used as the layout for many of the early Italian Renaissance churches. The cross was divided into five equal squares with the seating being placed facing inward towards the center square. The Greek cross plan did not allow for the movement from one square to the other without moving through the center; so I chose to rotate the plan 45 degrees creating an octagon. The octagon shape creates a focal point from each side. By lengthening three sides of the octagon, the center space became a Latin cross and emphasized the long axis.

Although I wanted the seating to focus on the center of the chapel, I decided to move the altar to the end of the long axis so that the speaker would not have an audience sitting behind him. The center of the octagon is raised to help keep a focus on it. The altar space then steps up higher to emphasize its importance. To help emphasize the idea of the cross and the focus on the center of the interior, I pulled the massing of the building upwards in the center. A problem still existed in defining the major entry into the building. It was my intent to design the chapel as a focal point between the cabins and the gymnasium. I chose to place the major entrances at the sides of the short axis. They are emphasized by raising the height of the ceiling.

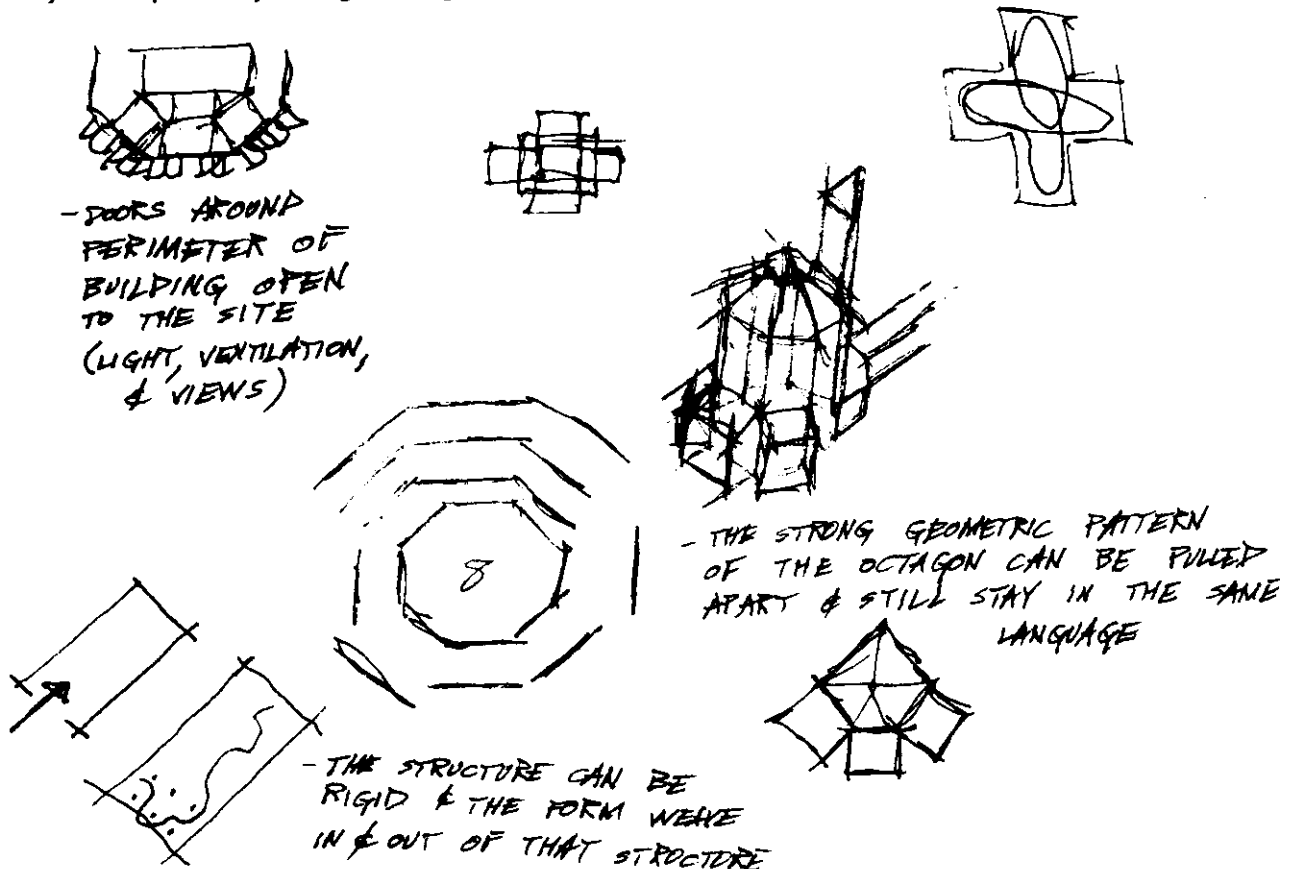

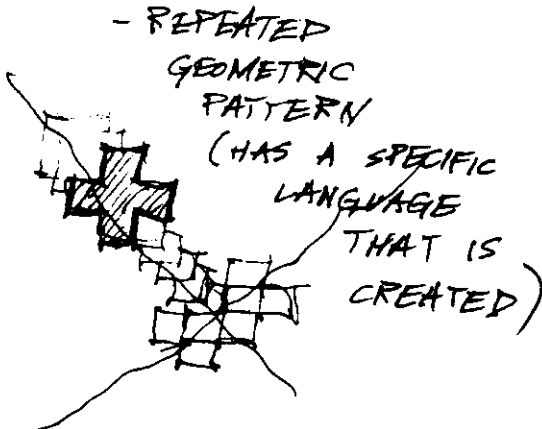
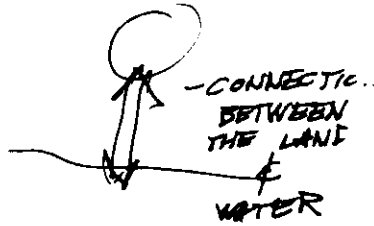
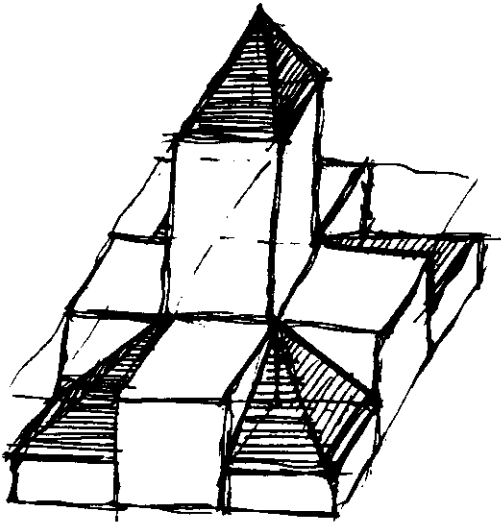
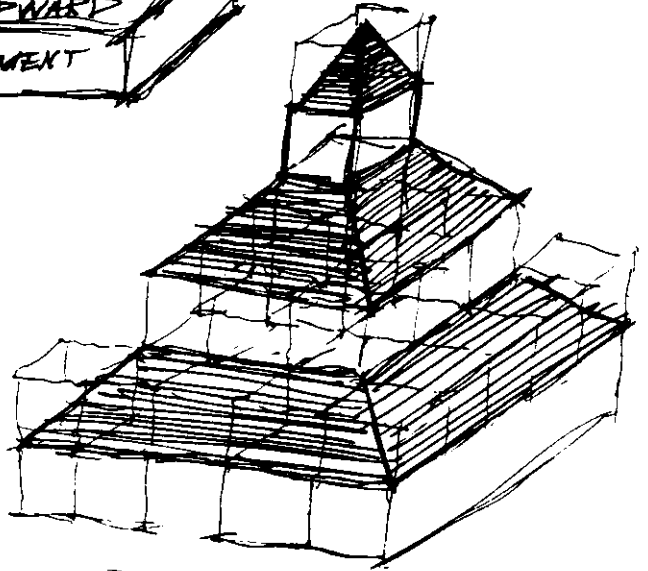
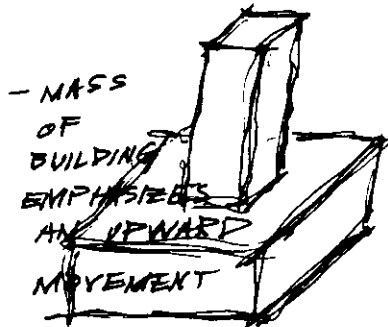
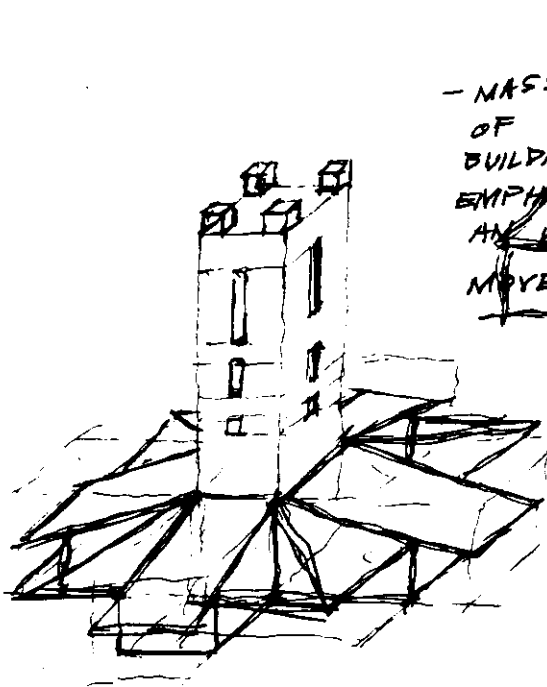

Structure

At this point in the design, I focused my attention on the structure of the building. I knew that the structure would be the key to how the pieces of the chapel fit together. I chose to use a similar method which E. Fay Jones used for the designs of several of his buildings. This method consists of building the structure out of many small pieces of wood connected together. I also wanted to expose the structure of the building on both the interior and exterior to provide a transition between the two.

The module which I developed through experimentation resulted in a 20 foot dimension. I chose to replicate the proportions of the chapel in both plan and elevation to provide a harmony between them. The columns which supported the framework for the roof above needed to be placed at the edges of the octagon to prevent blocked views from the seating areas. This meant that the span from one column to the other would require a large beam. My first idea was to design a flat truss to span the distance between the columns. These trusses would interconnect with each other, forming a cross which would help emphasize the center of the space. The first truss I designed was too thin, so I added a second layer of members in the vertical direction. This helped to emphasize the cross more and provided enough structural depth to support the span.

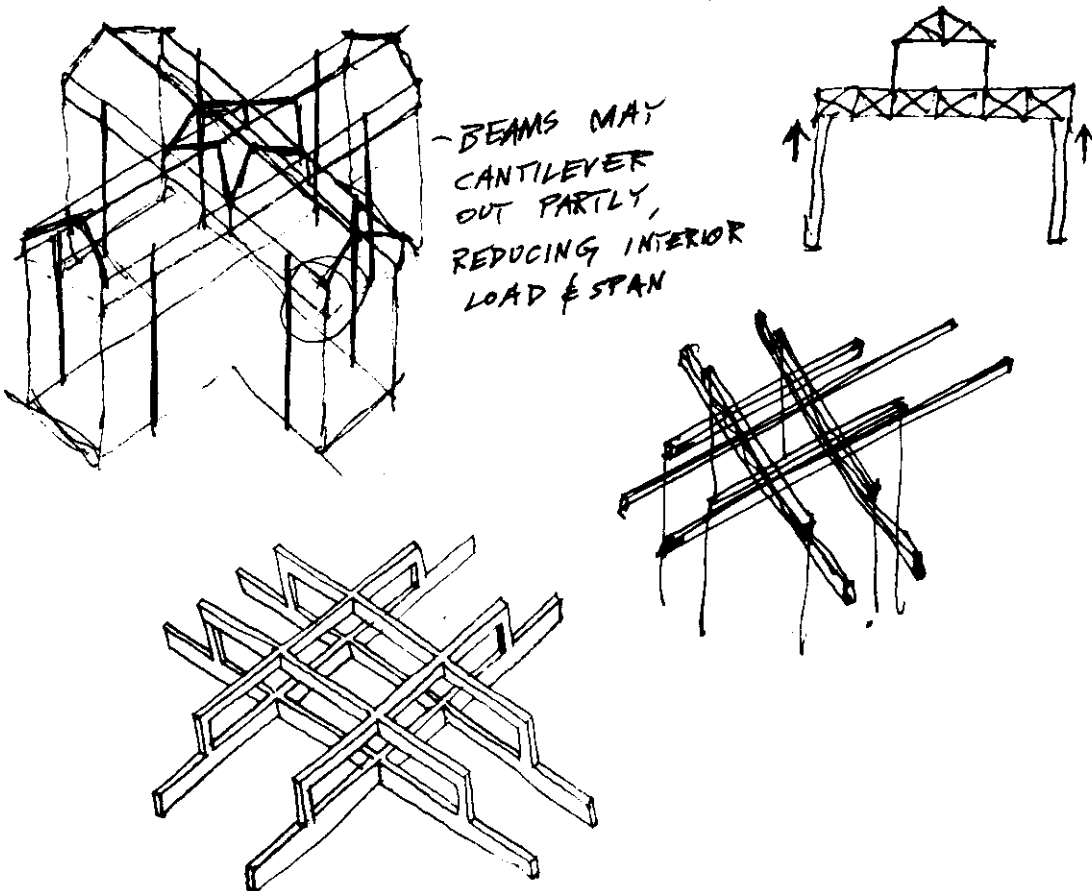

My intention from the start of the design was to make the structure as thin as possible in a network of interconnecting pieces. I did this to try to replicate the pattern of the trunks and branches of the trees next to the chapel. The triangular truss which is replicated throughout the chapel was designed using the proportion of an equilateral triangle and the proportions of the chapel plan. This triangular truss is used for spanning the distance of 20 feet between the large trusses to support the pitched roof. The two center members of the truss are extended to hang down like branches.

The original columns I designed started out as thick octagonal wood members. Later in the process I tried to design them into a cross shape made of many thin pieces put together; however, the shape of the plan brought me back to the original form. The octagonal column allows the small trusses of the three projecting bays to easily frame into the column. These small trusses were designed to support the roof of the projecting bays and to hold the floor of the upper balcony.

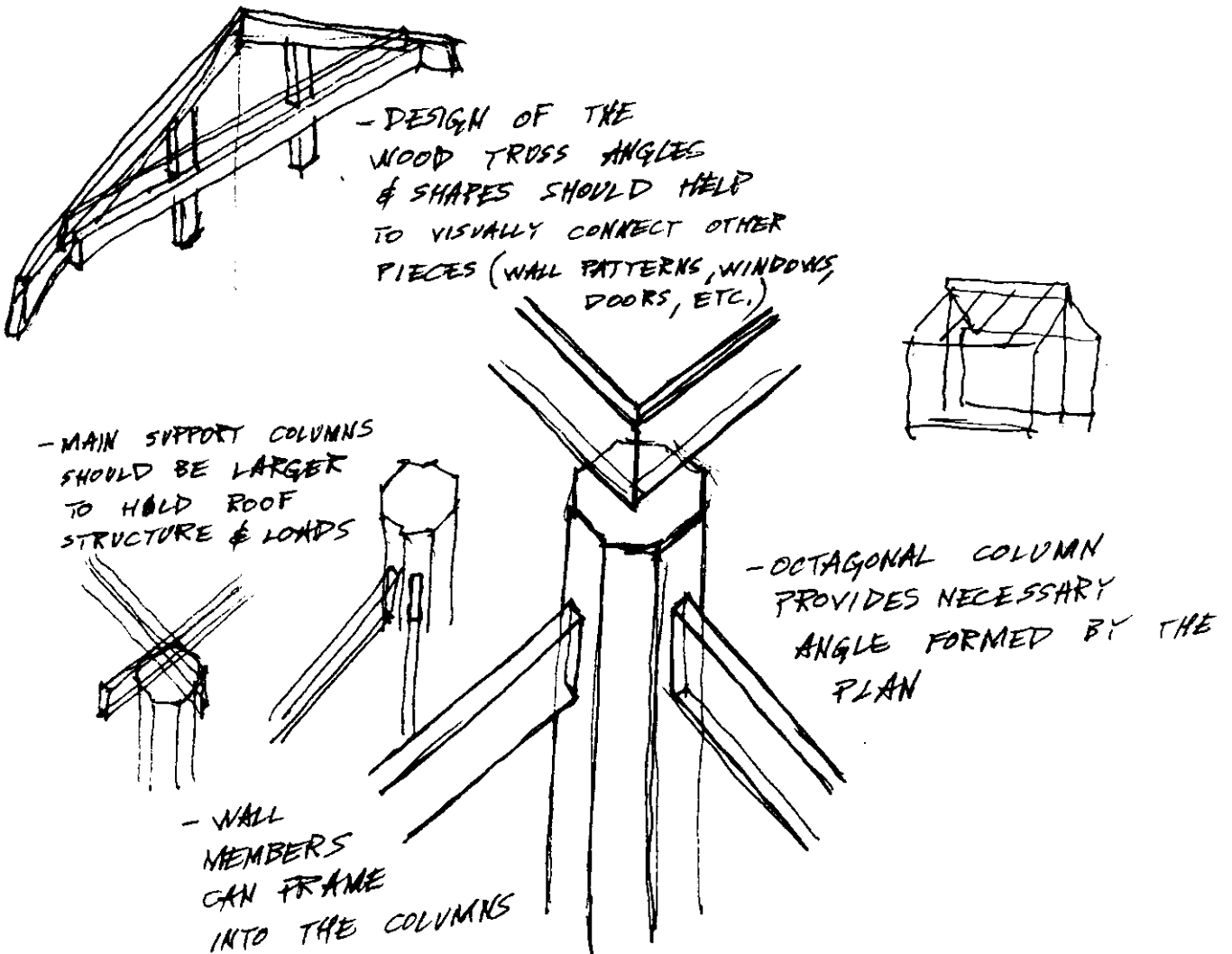

Elevation

The elevation of the chapel is based on the proportions of the shapes created in the plan when the cross is rotated 45 degrees and layered on top of itself. Using the 20 foot module, dimensions of 14 feet and six feet are created between the crossing points. In the elevation, the pitch of the roof was decided by using a six foot high rise and a run of 10 feet or span of 20. The original elevation consisted of four doors on five sides of the chape. Because the space between the two vertical members of the triangular truss is 6 feet, I was able to place two 3 foot wide doors in between them. This allowed me to place six doors on the five sides, opening the building up more.

The concept for the design of the doors was to place more glass surface than wood surface on each door to allow a greater penetration of light into the chapel. The glazing on the doors are turned in the vertical direction to emphasize the upward movement of the structure. Windows are placed above each door in the shape of the triangular trusses. The trim from these windows corresponds with the trim on the doors. To further emphasized the vertical direction, I stretched the facade of each bay upward and added vertical siding.

The structural frame of the building is designed to allow glass or siding to frame in between each member, keeping the expression of the chapel's skeleton on the interior and exterior.

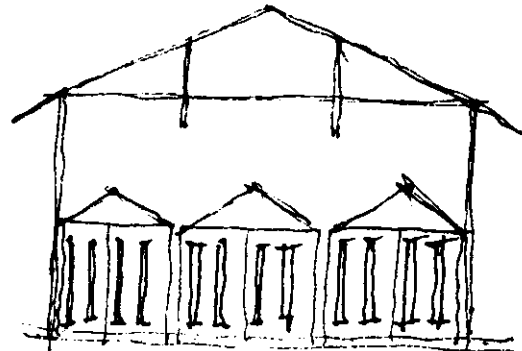

- PATTERN OF DOOR GLAZING
EMPHASIZES VERTICAL
DIRECTION

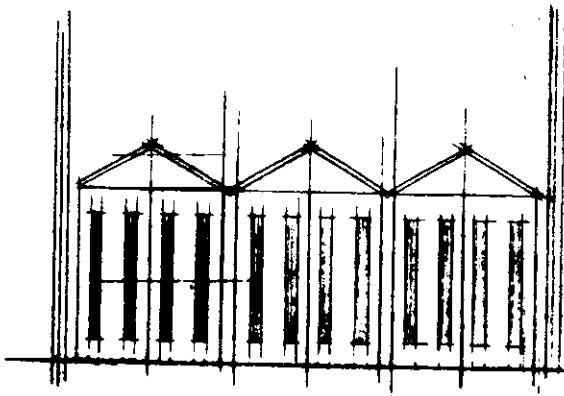

- MORE
GLASS
THAN
WOOD
SHOULD
EXIST
ON
DOORS

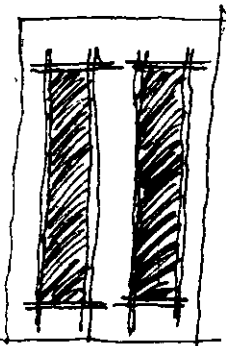

Section

The chapel was placed into the side of the hill to tie the building to the ground and provide a natural incline for the seating. By raising the altar space above the level of the central floor, a large space is created below due to the downward slope of the site. The area below the altar is used for bathrooms and the mechanical heating and airconditioning system. By placing the systems below the altar, they become hidden from view and do not disrupt the harmony of the buildings natural materials and forms. The air vents are located along the lower walls of the altar, allowing the air to move upwards into the space.

The balcony was created to provide more seating within the same area in plan. It rests on the small truss which frames into the eight major columns of the chapel. Two rows of pews are located around the inside perimeter, leaving circulation space along the exterior wall. In my original plan, the staircases leading to the balcony were exterior elements which framed into the corners of the chapel. After going through several unsatisfying designs, I moved the stairs to the interior. Two spiral stairs are located on two of the corners of the octagon. These stairs are too narrow to provide enough exit room for the capacity of the balcony seating. To solve this problem, I decided to extend upward the stairs which move down to the basement. These stairs bring you up to the balcony level at the two ends.

The octagonal stairs located in the very center of the chapel were designed to slide into the wall, providing a larger main floor space to be used for special functions. A curtain is placed at the sides of the large columns to divide the three bays off from the main space. A curtain is also placed at the side of the two columns located at the corners of the raised wall which runs through the short axis of the plan. These curtain provide a partition for plays and other performances to take place.

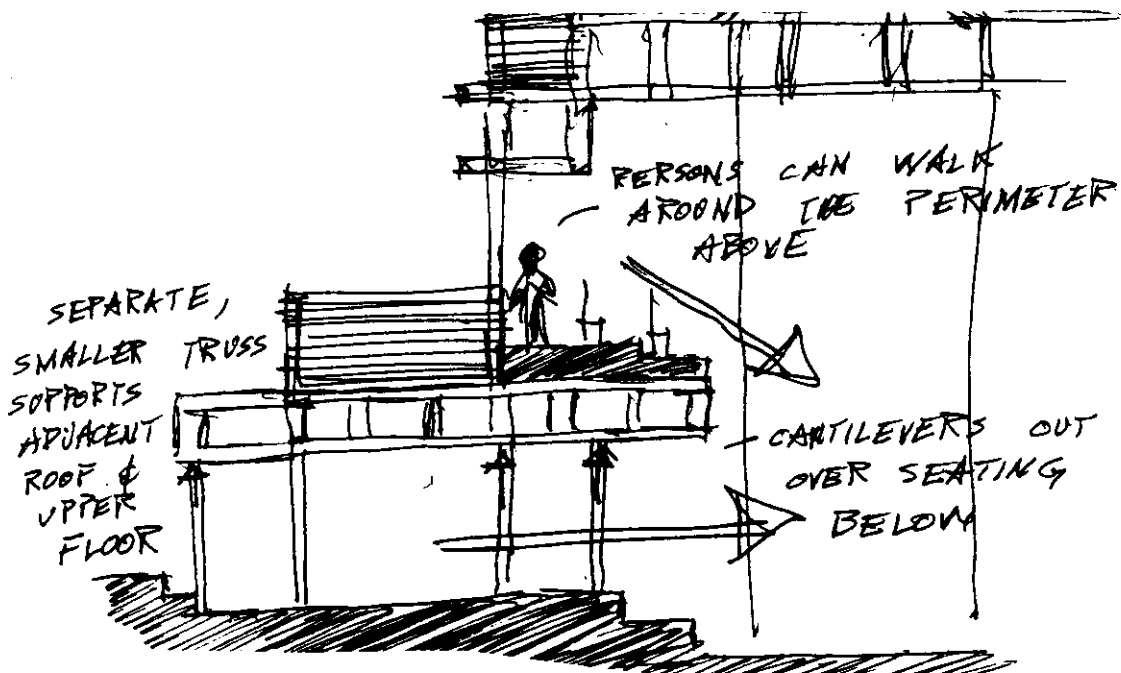

Details

In the ideals of organic architecture, each piece of the building is an integral part of the whole. Using this philosophy, I designed several of the small elements within the building. The design for the podium comes from the plan. The triangular top replicates the same angles of the platform on which it rests. The legs of the podium / lectern are made of several thin wood members. The top of each leg is made thicker to support the triangular piece. The individual lights were created to illuminate the structure at night. The opening at the top and bottom directs the lights onto the structural members which it is connected to. The frosted glass allows lesser amount of light through to soften the rest of the interior. The proportion of the small vertical pieces of the light is based on the same one as that of the triangular truss.

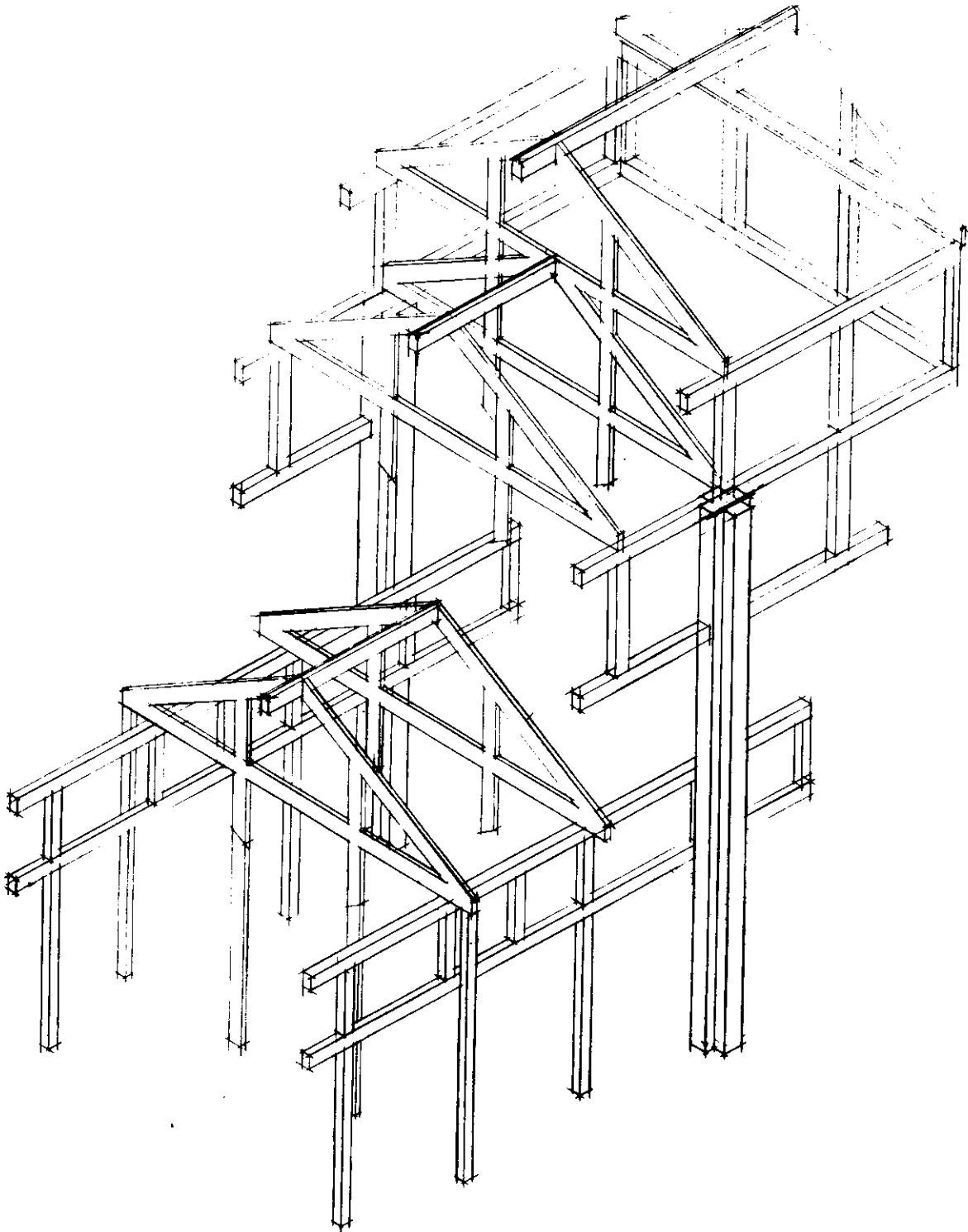



Final Design

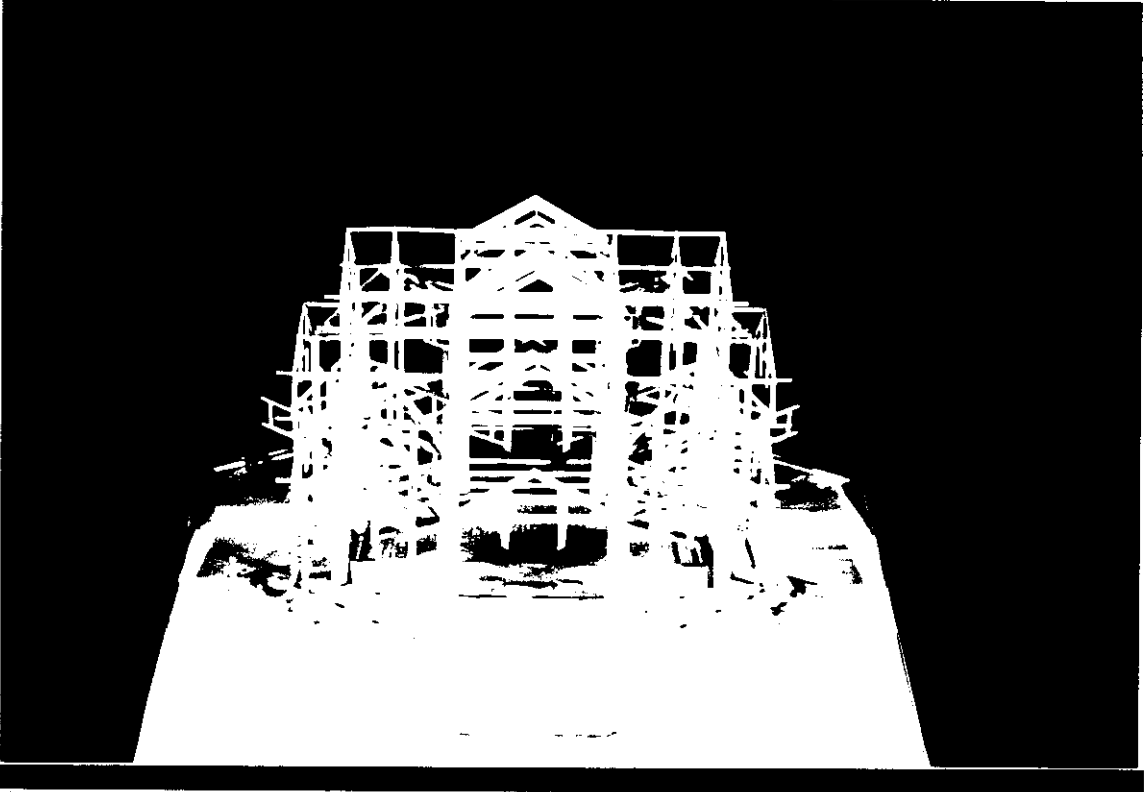
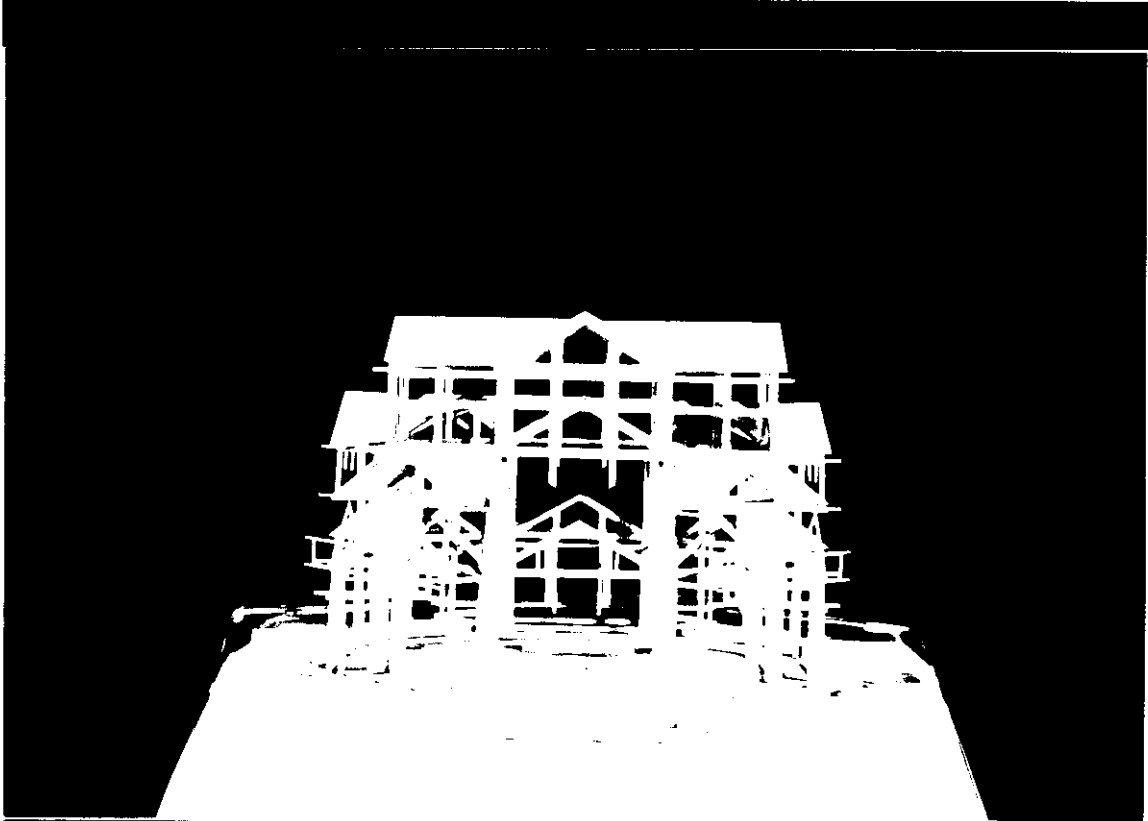

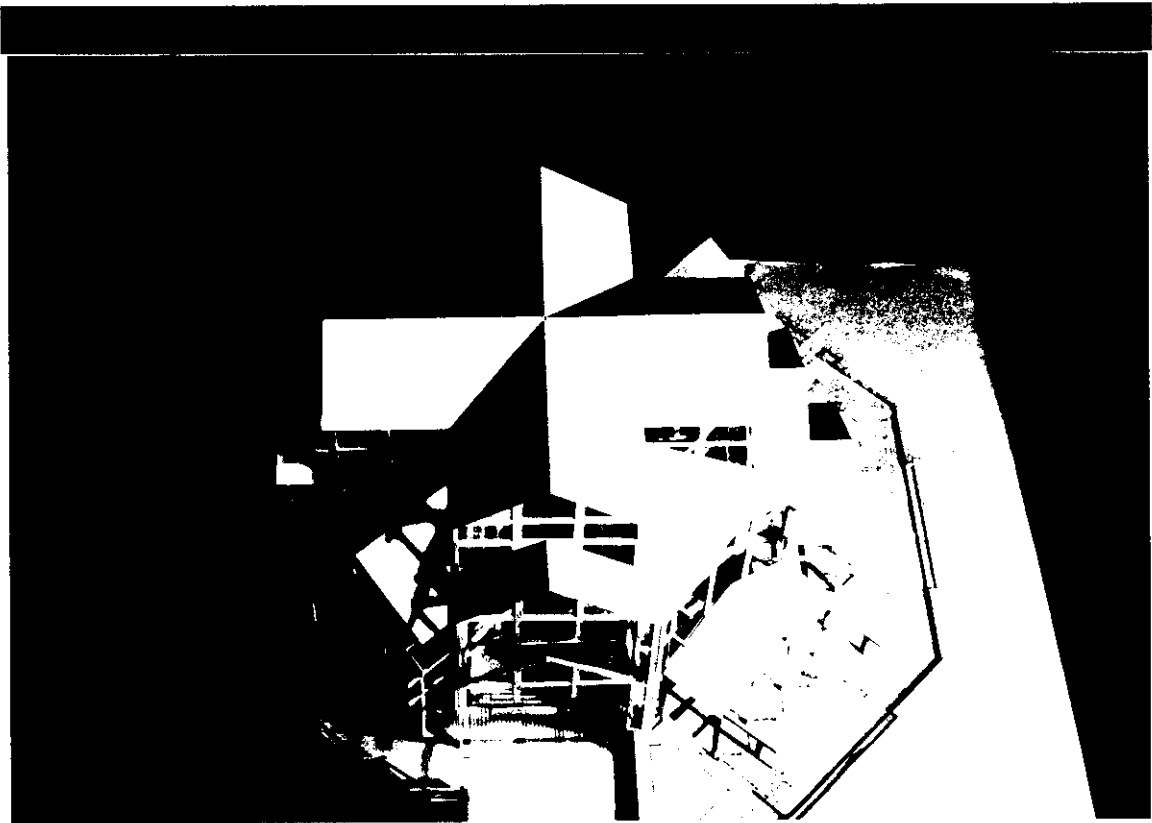

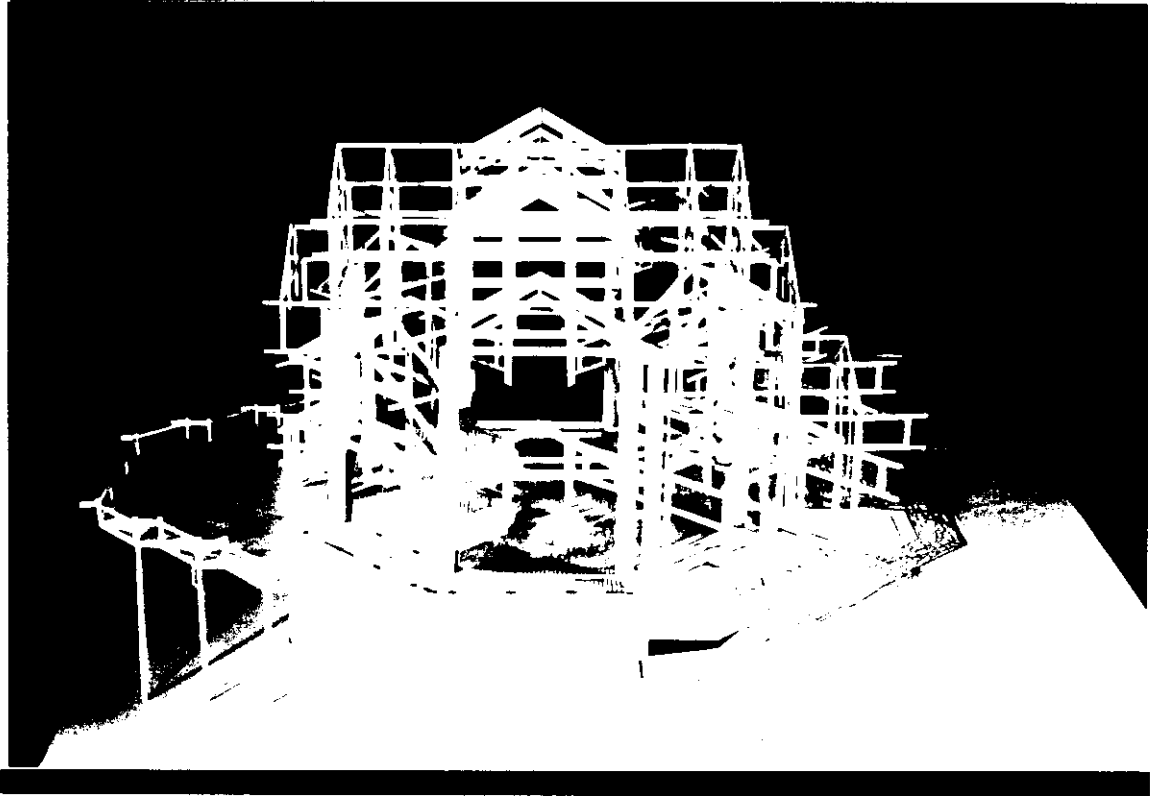
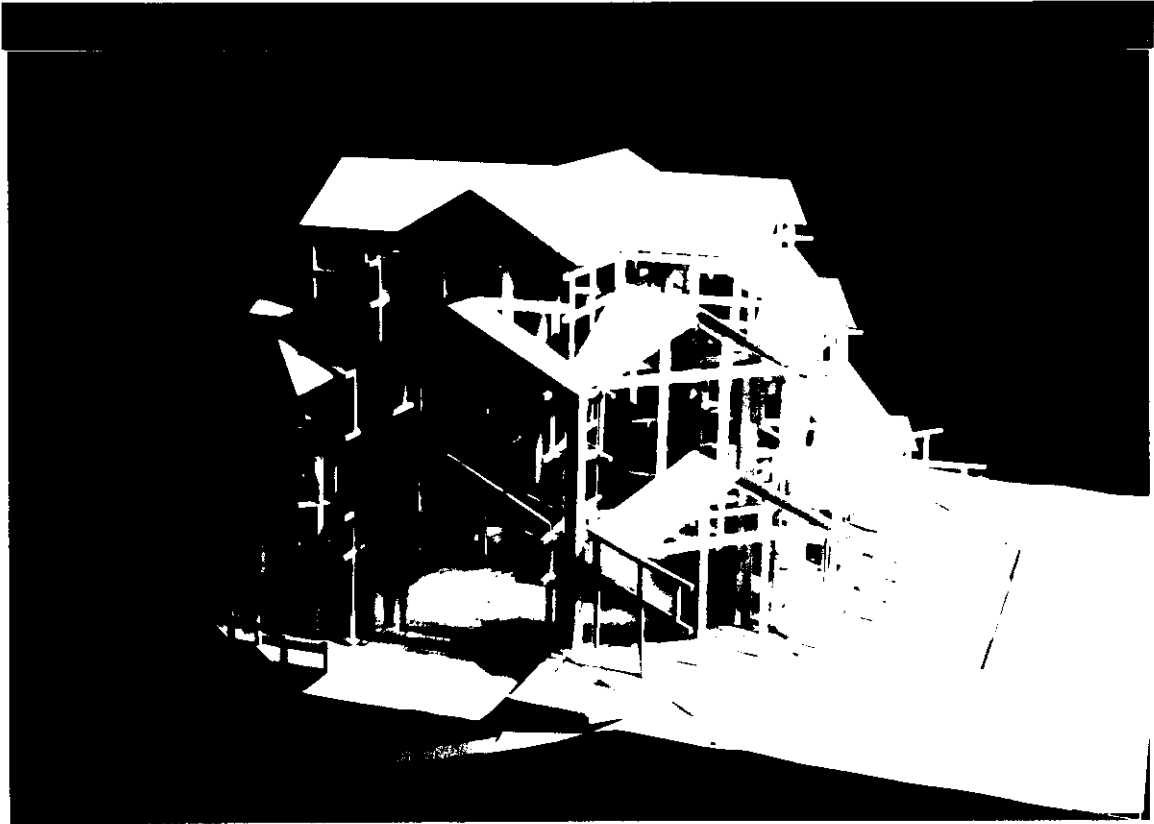

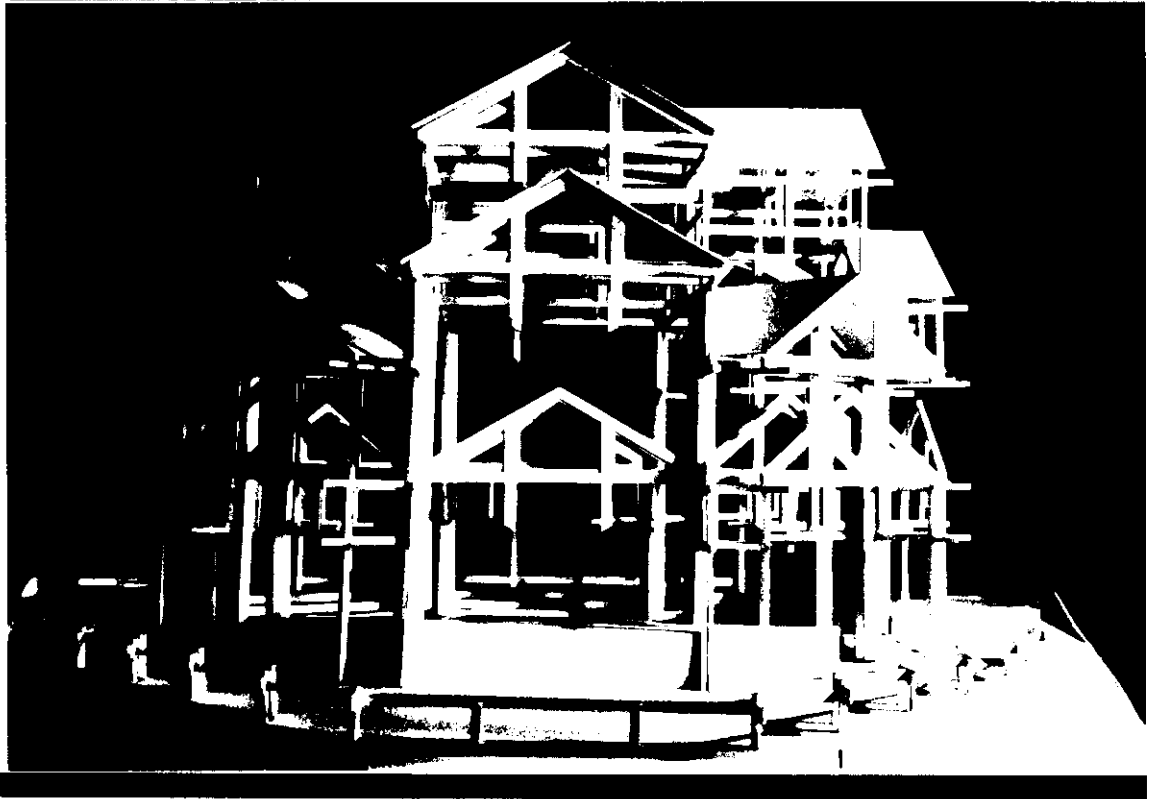
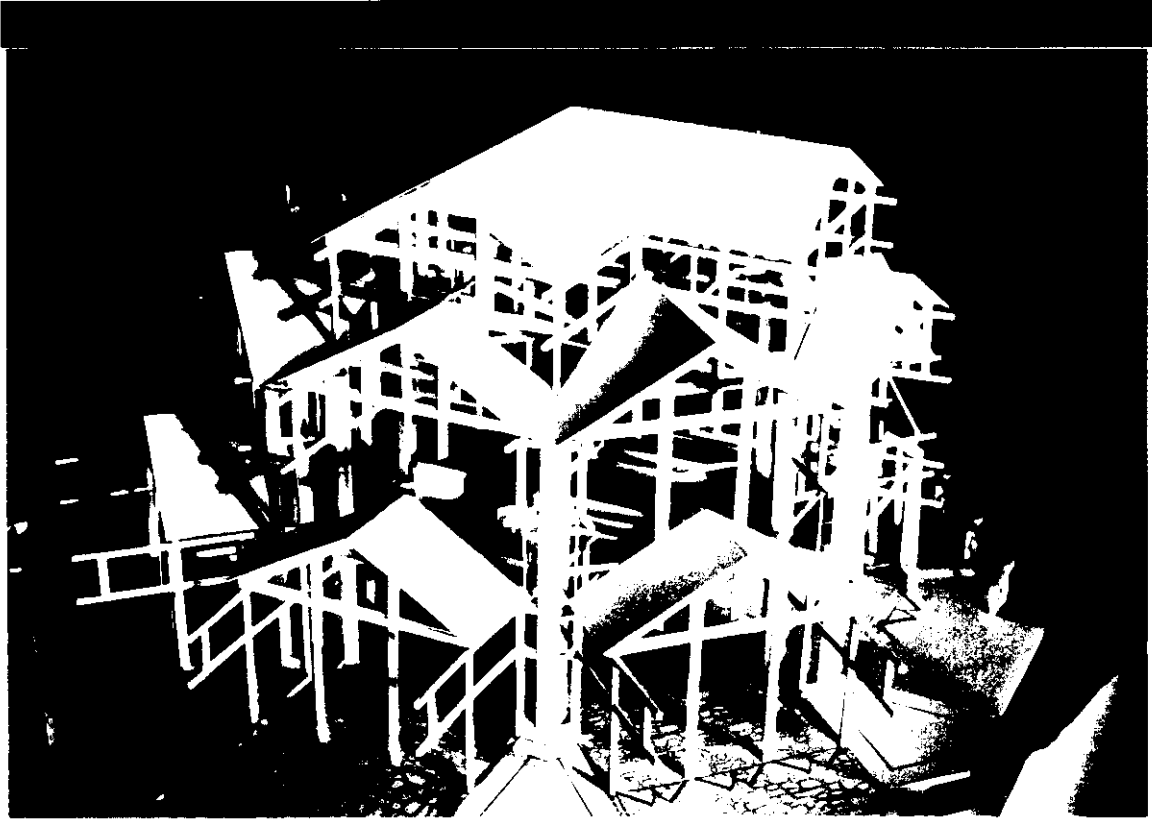

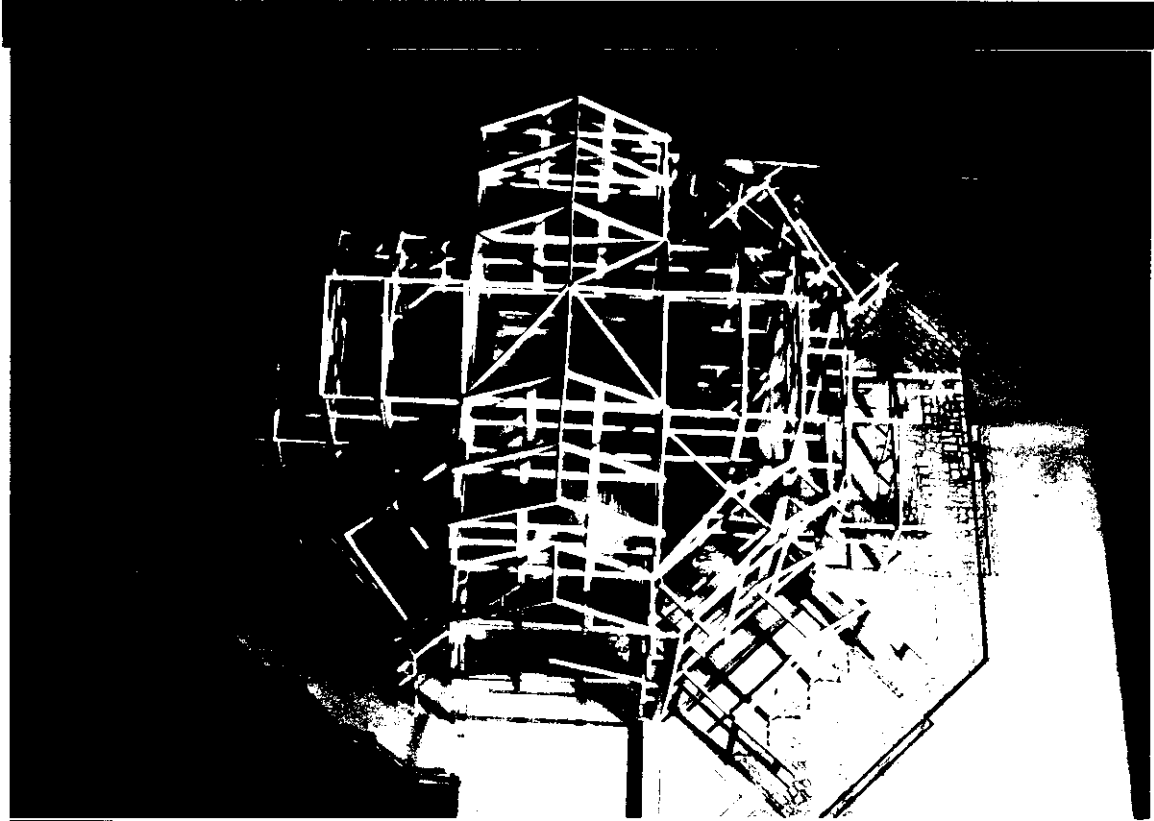

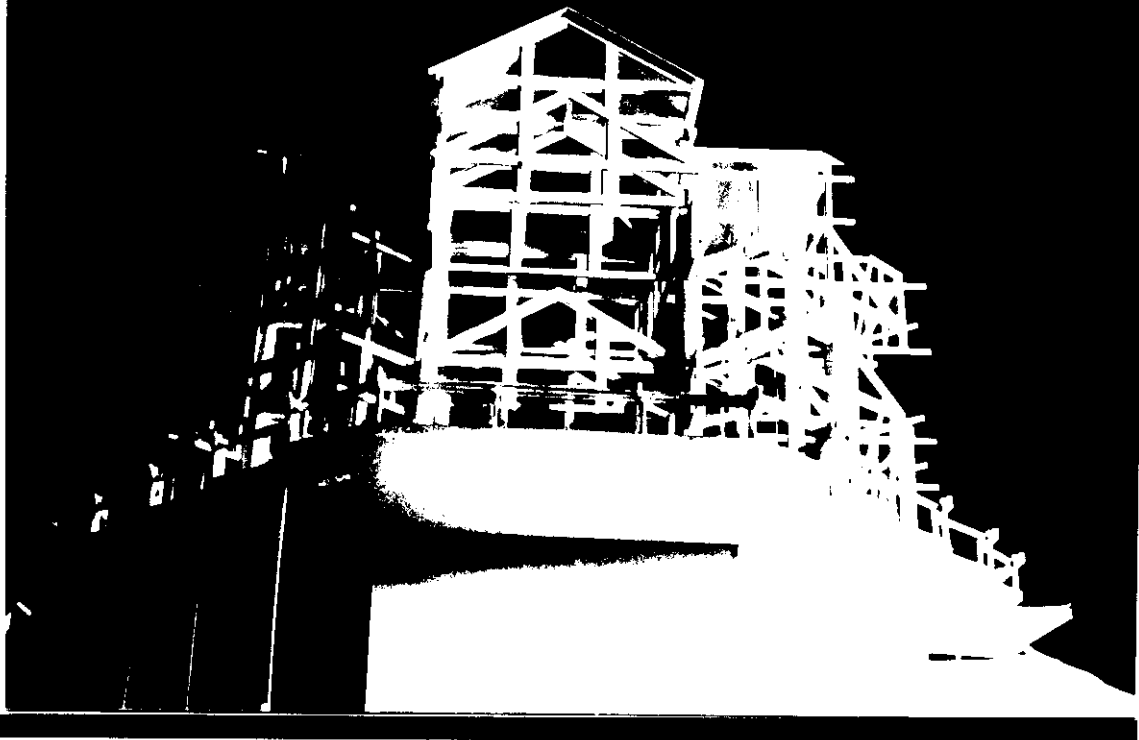
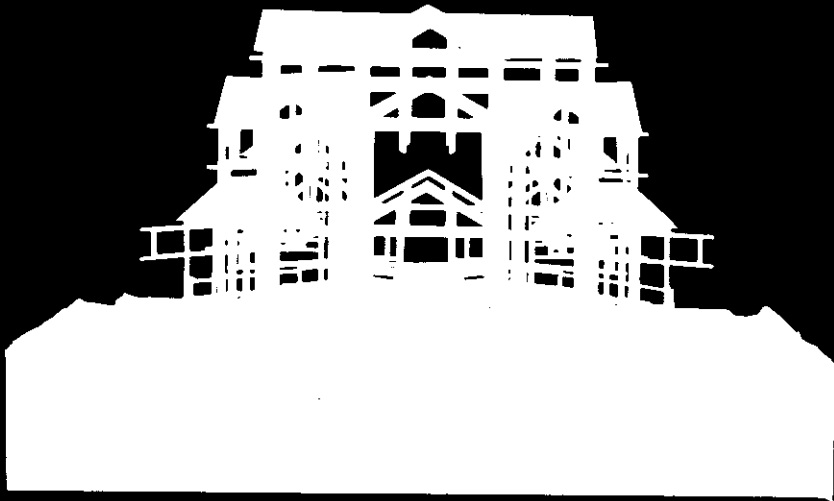

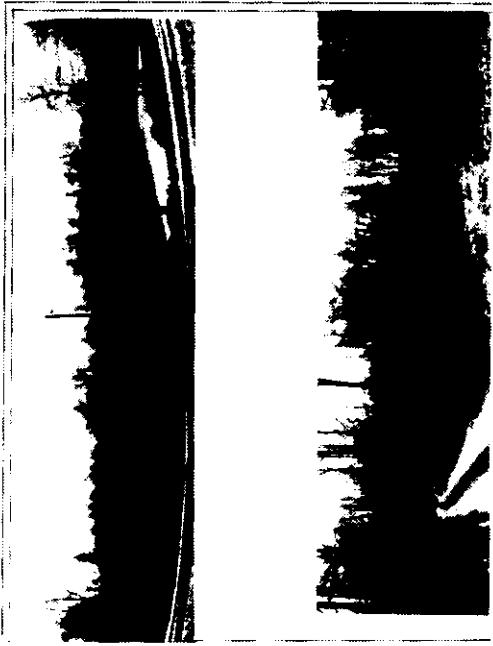
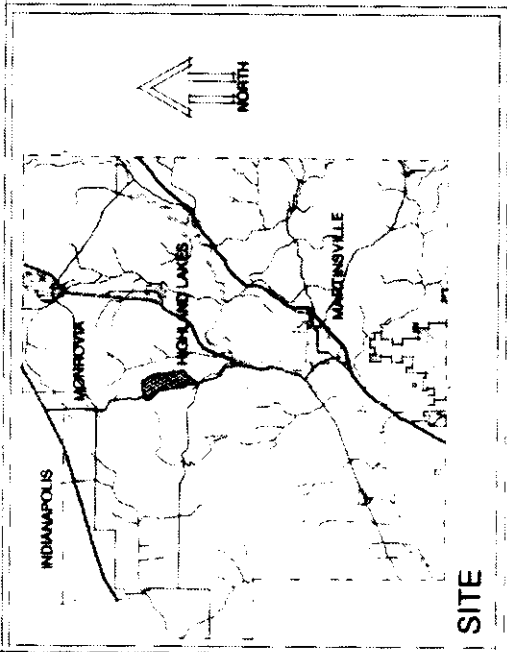

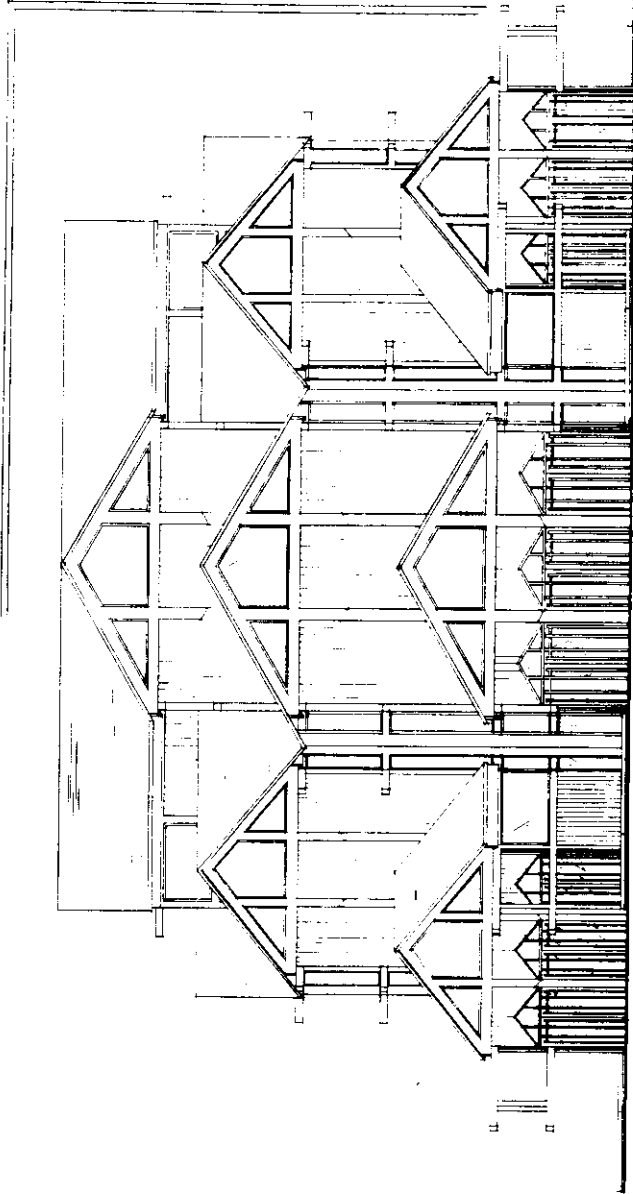

FRONT ELEVATION

SCALE 1/4" = 1'-0"

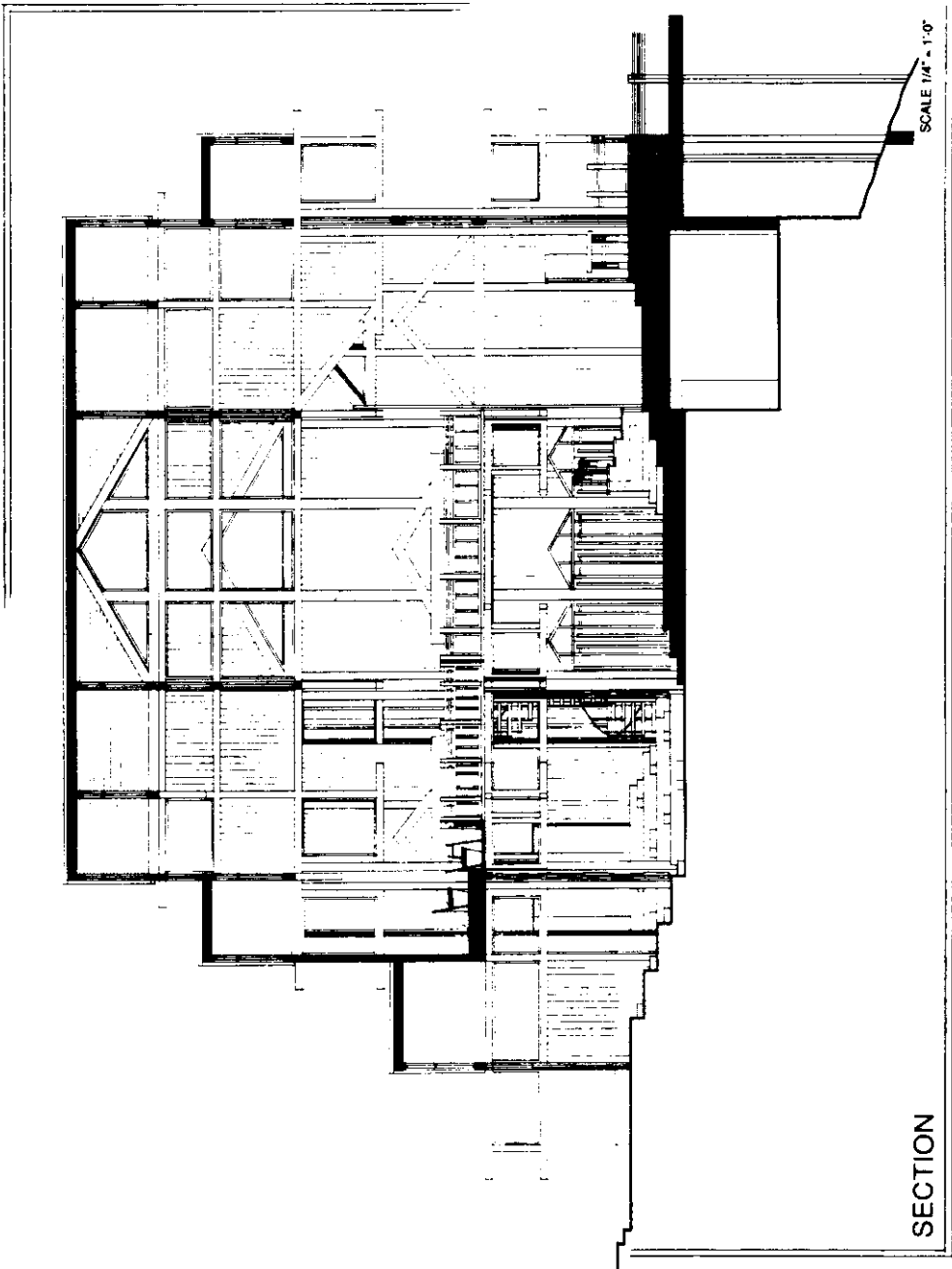

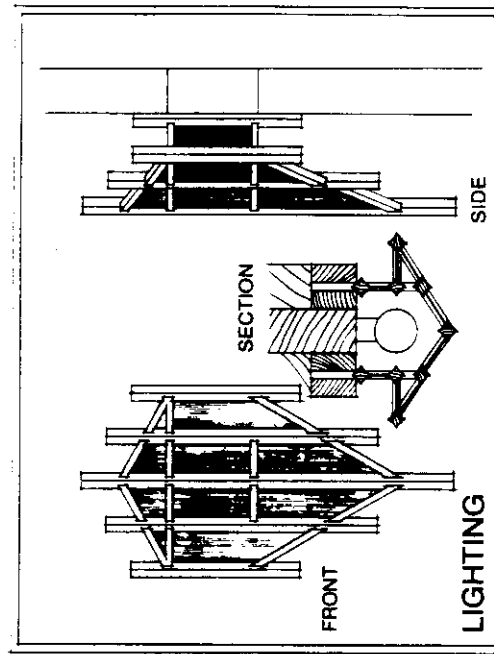
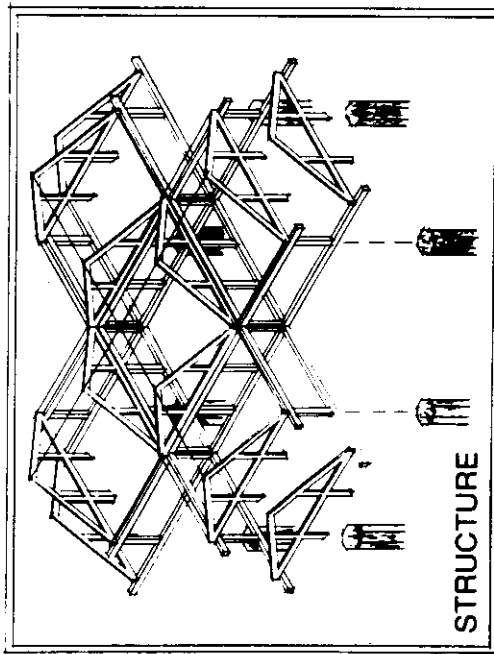
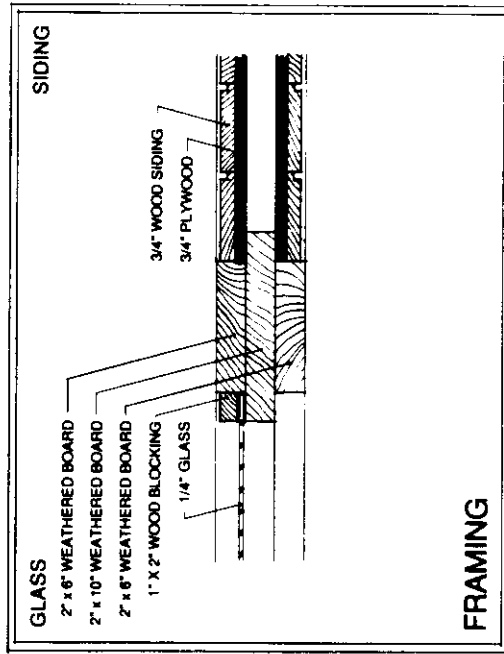
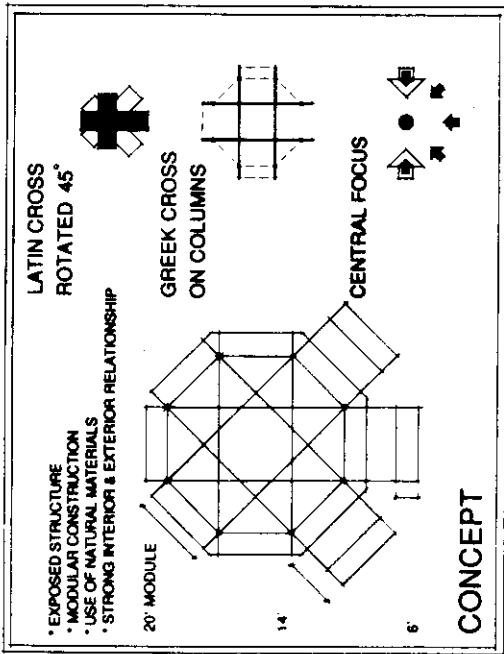

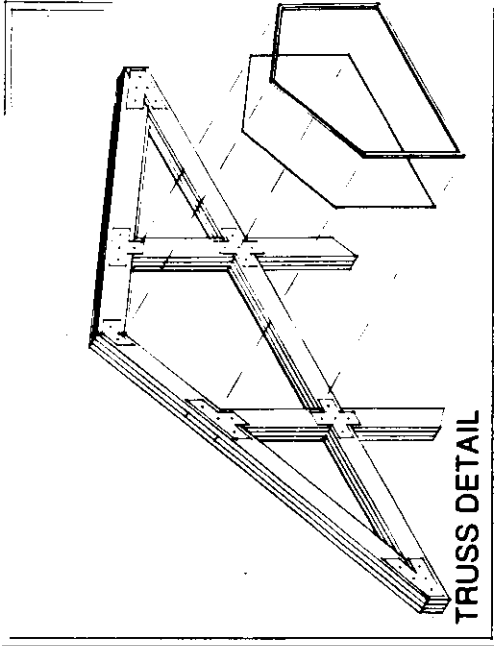

TRUSS DETAIL

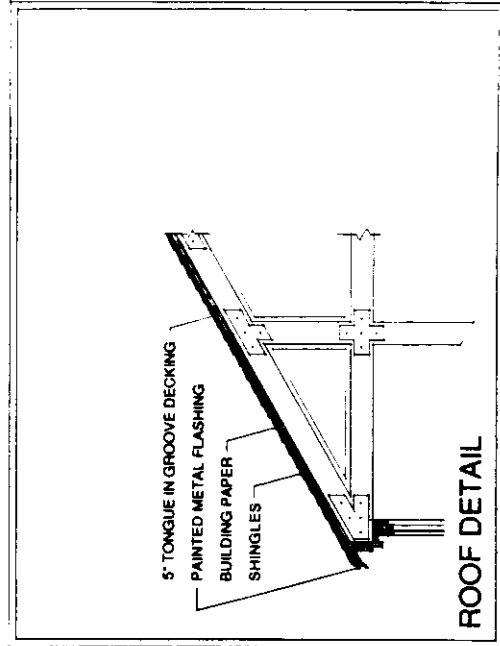

ROOF DETAIL

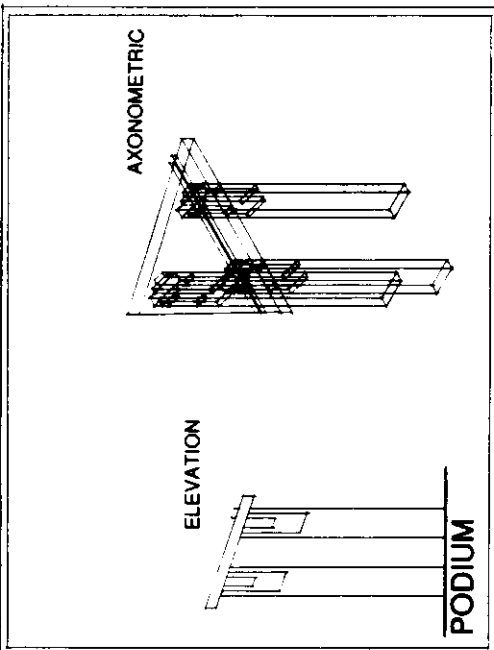

PODIUM

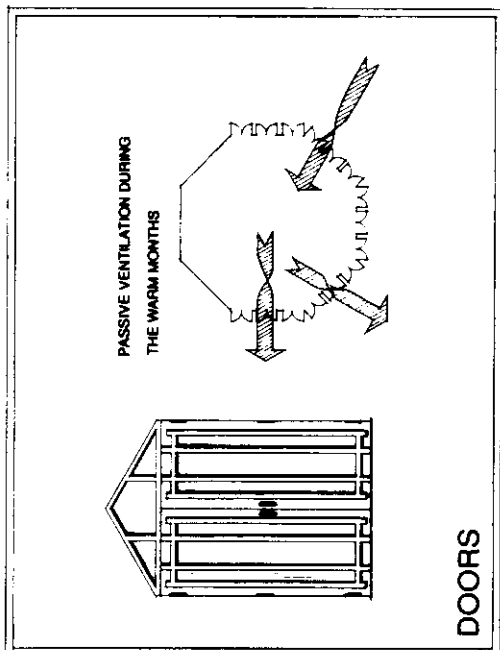

DOORS



Reflection

Presentation

During my thesis presentation, many valuable comments were made. One of the major items which needs to be included in this packet is a detailed site plan of how the chapel and the other buildings relate to one another. Because of the detail in which I approached my design, several questions were addressed to why I had not taken the time to detail some of the other elements in the design. If time were available, I would detail each piece of the building to make sure that they fit within the context of the building.

Some of the other items addressed were the following:

How does the design of the railing allow the people in the balcony area to see and hear the speaker? The railing is lower than the standard code to allow a direct view to the podium. The space between each rail post could be made of glass or wood. If glass is used, you will be able to see through the railing; however, the glass must be thick enough to keep from being broken.

If the chapel is to be used for several different functions, are spotlights hung from above and how do you adjust them? My idea to solve this problem would be to hang the lights from the truss system above. The lights could be hooked onto a pulley system so they could be adjusted and maintained properly.

The doors and windows will allow ventilation during the warm months; however, the air will be very still inside the large volumed interior space. Where would you place fans to help move the air? The fans would be designed in the same manner as the light fixtures. I would place four of them at the intersections of the main truss above the central space. A few other ones would be placed above the balcony seats.

One of my main goals was to create a treelike structure which moved outwards into the site. When the siding is placed between the structural members, some of this feeling is lost. One of some of the truss pieces should project further out from the building to help emphasize this concept even stronger.

Which of the windows can be opened? It was my intent to allow the windows at the corners of the octagon be able to swing outwards as do all of the doors.

Conclusion

The basic philosophy of organic architecture is a very strong concept and one which I believe in strongly. I feel that it is necessary for architects to understand how their buildings effect the people and things around them. Organic architecture attempts to provide a harmony between the building, site, and its users. The final design of my project takes a step towards this type of design; however, it still falls short of accomplishing all of my intents.

Working in a very detailed approach taught me a lot about how the pieces of the building work together to make the whole. Developing the connections and individual members of the structure helped me to better understand how wood can be used as both a decorative tool and a structural material. I feel that with a few modifications, this chapel could easily be built and would serve its function quite adequately.



Bibliography

Bieler, Andre. Architecture in Worship. Westminster Press. Philadelphia. 1965.

Buxton, David Roden. The Wooden Churches of Eastern Europe.: An Introductory Survey. Cambridge University Press. New York. 1981.

Clowney, Paul. Exploring Churches. W. B. Eerdmans Publishing Co. Grand Rapids. 1982.

Cook, George Henry. Mediaeval Chuntries and Chantry Chapels. Pheonix House. London. 1963.

Fifty Modern Churches. Church Building Society. London. 1947.

Kennedy, Roger. American Churches. Crossroad Publishing Co. New York. 1982.

Kidder, Frank Eugene. Churches and Chapels. The W. T. Comstock. New York. 1910.

Maguire, Robert Alfred. Modern Churches of the World. Dutton. New York. 1965.

Mason, Grant Carpenter. Frank Lloyd Wright to 1910: The First Golden Age. Van Nostrand Reinhold. New York. 197-?

Ronner, Heinz. Louis I. Kahn: Complete Works, 1935-74. Westview Press. Boulder. 1977.