

THE EVOLUTION AND TRANSFORMATION OF TRADITIONAL IDENTITY AND VALUES INTO  
NEW BUILDING PATTERNS IN HOUSING THAT IS ROOTED IN TRADITION

## ACKNOWLEDGEMENTS

---

To my parents for their never ending support, guidance, and faith. Thank you.

THESIS COMMITTEE CHAIRMAN: Prof. Stan Mendelsohn

THESIS COMMITTEE MEMBER: Prof. Alfredo Missair

Warmest thanks to both Prof. Mendelsohn and Prof. Missair for being inspirational to my project and for their wealth of knowledge in the area of my studies. A special thanks to Prof. Stan Mendelsohn for allowing me to be a part of his memorable trip to the Middle East, that opened my eyes to the world and has changed me permanently.

# TABLE OF CONTENTS

## PREFACE TO THESIS

Introduction.....	1
Abstract.....	2
Thesis Position and Implications.....	3-6
History of the Traditional Jewish Neighborhood Outside the Walls of the Old City.....	7-14

## ANALYSIS

Traditional Neighborhood Analysis.....	15-30
Contemporary Neighborhood Analysis.....	31-37
Constructs: The Site.....	38-41
Constructs: The Built Form.....	42-46

## SITE STRUCTURE AND CONCEPTS

The Region and Location.....	47
Map of Site and Surrounding Area.....	48
Conceptual Land Use Options.....	49
Movement Patterns and Connections.....	50
Landscaping Aspects.....	51
A Look into the Preservation of Jerusalem's Skyline.....	52

## HOUSING PRINCIPLES AND CRITERIA AS RELATED TO TRADITIONAL/CONTEMPORARY ASPECTS

Summary of Criteria from Traditional Analysis.....	53-54
Type Plan Analysis--Traditional/Contemporary.....	55-56
Climate/Material/The Site/Image.....	57-58
Interview with Arie Rohamimoff.....	59

## PROGRAM

Density/Site Content.....	60-62
---------------------------	-------

## TRANSLATION INTO DESIGN FORM

Design Types.....	63-65
Typical Floor Plan.....	66
Massing.....	67-68
Schematic Partial Site Plan.....	69
Images.....	70-72

## THESIS INSIGHTS AND CONCLUSION.....73

## APPENDIX.....

# **PREFACE TO THESIS**

---

G. Evelyn Hutchinson states in the book Knowledge Among Men, that "we need the rich time dimension to help us avoid the all too common triviality of living in the moment, as a continuous prelude to rushing thoughtlessly into the future." Amos Rapoport goes on to analyze this in his book House Form and Culture, that "we cannot assume a sudden break with all that went before, or that we and our problems are so different that the past has no lessons for us. While technology may progress, architecture does not necessarily do so."

These thoughts are the basis of this thesis, which wishes to identify certain traditional ethnic values and identities in modern Jewish housing communities in the city of Jerusalem. It is proposed that these values and identities will be broken down from case studies into constructs and studied with the result that through evolution and transformation new patterns which are rooted in tradition will be used in the building of these neighborhoods, thus creating new neighborhoods with great vitality that contribute to the city as a whole rather than ignore its visual impacts and cultural context.

My career goals include continuously building upon my knowledge of architecture; its theories and history. Also, to help promote the field of architecture as a critical part of creating new vernacular architecture for people on a more intimate scale (i.e. housing forms). Not to be seen completely as luxury, but mostly as a necessity (although not exclusively utilitarian) in building a more successful community fabric as a whole.

My thesis studio expectations, aspirations, and areas of interest include getting an insight into the effect of a culture's philosophies, images, and traditions on urban shelters. The ultimate goal being the gaining of sensitivity as a designer towards the relationship between society and shelter. To then explore ways to apply this knowledge with the aims of contributing and enhancing my own development.

## THESIS POSITION AND IMPLICATIONS

Jerusalem is a city made up of a mosaic of cultures and settings and in many respects is a unique blend of nationalities and traditions of countries mainly from Asia, Africa, and Europe. The processes of development in Jerusalem have been dominated in recent decades by political and time constraints with the result that urban development does not always address the basic concepts and expressions that make up this special environment.

Urban housing in Jerusalem is being fragmented by norms and processes that relate more to city planning in general than to Jerusalem in particular. Christopher Alexander from the Jerusalem Committee has stated that "Jerusalem is made up of a number of urban villages." These villages are losing their sense of cultural and traditional community interaction through the adoption of western attitudes, symbols, and images in the planning and development of their shelters. These villages, as autonomous elements, contribute to the vitality and success of the city as a whole and therefore their identity and values should be preserved. Through the evolution and transformation, new building options and patterns that are rooted in tradition can be created.

These diverse cultural attitudes and symbols, images and identities are important contributions to the city as a whole and should therefore be enhanced and preserved through the enrichment and enlightenment of applying the vernacular architecture of a certain ethnic culture or cultures enhanced through evolution and transformation to the design-

ing and planning of urban shelters for that culture. By addressing specific cultural themes and influences in the planning and design of shelters as ingredients and criteria for design, the fabric of communities within the built environment will be richer and have greater vitality and integrity. The question arises-- why study the primitive and preindustrial house form in this day and age of rapid change? In his book House Form and Culture, Amos Rapoport tries to answer this question. He states that one reason is that these houses are the direct expression of changing values, images, perceptions, and ways of life. Also, the need for cross-cultural studies and comparisons are useful in the following two ways: 1/From the practical point of view, different cultures and subcultures coexist in cities, with the consequent need for different housing and settlement patterns; 2/Comparisons of this type can offer an insight into the basic nature of shelter and dwelling of the design process and the meaning of "basic needs."

A certain set of criteria must be set up when dealing with the design issue of housing as a part of a community for a certain ethnic group or groups. The approach taken will include a number of options including the following to determine the relationships of people and their activities to setting:

- 1/Patterns of living such as:
  - a/Use of outside areas including public space, private space, and semi-private space.
  - b/Use of inside areas that may be unique to this ethnic group. For example, the use of patios for receiving guests, the way people use entrance and approach areas, the way they decorate, and the use of gardens.
- 2/Privacy
- 3/Density patterns
- 4/Symbols and images (including gateway, use of the arch above windows, and the use of Jerusalem stone as a building material).
- 5/Movement patterns
- 6/Sensitivity to the landscape
- 7/Micro-climate
- 8/Personal identity/territory
- 9/Potential growth

These constructs will be studied individually in a number of traditional Jewish neighborhoods in Jerusalem. Similar ones will be grouped and from these given constructs, new options will be studied that could be applied towards new developments. These constructs will be shown as graphic representations. The new possible options

will be also depicted graphically for clarity and publication reasons.

Once these new graphic options are evaluated they will be used to put together various prototypical three-dimensional models and applied to a chosen site. They can then be easily evaluated and further refinements can be made as to the successful and unsuccessful options.

Comparisons will also be made between the old traditional neighborhoods and modern developments by the use of sketches of various similarities (i.e. the gateway concept as one example) between the two. Studies (including sketches of traditional and modern courtyards) will be done also to show the success and vitality of traditional neighborhood elements vs. the unsuccessful modern neighborhood elements.

By applying the interpreted findings, principles and guidelines will be proposed to be discussed and used as the basis of design development. Using generic images to convey images and symbols; and diagrams to demonstrate and develop principles and guidelines. It is hoped that lessons from this study will be drawn that could apply to other cities such as Chicago, New York, San Francisco, and various other international cities.

Firsthand exposure includes case studies made of various ethnic communities. While on a Middle Eastern Study Tour, the author of this proposal had a chance to visit some ethnic neighborhoods. In Jerusalem regular visits to traditional Jewish neigh-

borhoods and tours of the various modern satellite communities were made. Three weeks were spent on an Israeli Kibbutz adopting to their lifestyle. While on this kibbutz other kibbutzim were visited and studied. In the town of Acre in Israel, a visit to traditional Arab housing was made and studies of its layout and the reasoning behind it were made. And, while on the island of Santorini in Greece, the author of this proposal lived in a renovated traditional ethnic village, which at one time was a community of cave dwellers.

Besides this firsthand exposure, there will be access to other information obtained by others during the Middle Eastern Tour such as information on various ethnic communities in Venice, Italy; and in Alexandria and Cairo, Egypt. Also a bibliography of various written sources which will be used as resources. Notes will be taken from these resources. Exact text quotations will be used as will the reader interpret the text, form opinions and use graphic and three-dimensional representation of the concepts involved. An ongoing dialogue with Ronen Kishon and Yaron Turel, two Jerusalem city planners, will be kept to further answer any questions that may arise. There will also be an evaluation by both Kishon and Turel of the set of guidelines proposed as to how effective they would be if actually applied to a project.

These studies will be concentrated in Jerusalem. This city was chosen over other cities because of its kaleidoscope

of urban villages. For example, the four quarters within the Old City: the Armenian, Jewish, Moslem, and Christian Quarters; identify important ethnic parts of Jerusalem. Jerusalem's distinct traditional Jewish neighborhoods and Arab villages outside the Old City are two other groups that are prominent within the city.

The actual site chosen will be used as a given base for consideration. It is located in the northern region of Jerusalem. The site was selected by the recommendations of experts such as Yaron Turel, a city planner, and architect David Kroyanker. In Kroyanker's book Jerusalem Planning and Development 1979-1982 (p.16), he states two obvious reasons for this site as a potential future area for housing development. 1/There is a wish to create a more united integrated city by allowing a continuous urban development from the northern neighborhoods to the city center. 2/The observable shortage of building areas in Jerusalem.

Because of these reasons, the feeling is that the city of Jerusalem and the particular site chosen would be the most logical choice in which to implicate the findings. In analyzing the site the physical, topographical aspects of the site, the climatic impacts on it, and the adjacent areas of other cultural neighborhoods will be looked at, as will the impacts of the fact that Jerusalem itself is located on a watershed between the Mediterranean Sea and the desert region of the Dead Sea.

Recent housing developments in Jerusalem have been insensitive to the user and have in recent years been influenced by geopolitical and military considerations. Traditional symbols and images have been used in this housing to the extent of over exaggeration. The over use of the arch above windows, entries, etc., is one example. Another example is the unsuccessful development of the central public courtyard--traditionally an extensively used space, now a mostly barren cold atmosphere or unexistent all together. There has also been very little consideration by these developments on their environmental and visual impacts on the visual image of Jerusalem.

In summation, the author of this proposal expects to develop criterial and guidelines for housing in strong ethnic communities by preserving that group's identity and values. These symbols and values will be transformed and evolved into new patterns, yet retain their traditional roots. It is hoped that by obtaining this criterial that in the future these neighborhoods will become more successful sub-communities within the international city itself.

In being able to understand present norms and influences in a society, one must study the past. The past tells a person about what has preceded and can give an understanding as to what became as a result of the existing cultural attitudes and traditions of a society. The following wishes to look at the history of the Jewish population in Jerusalem and their development of communities outside of the Old City. It is thought that by studying these traditional housing neighborhoods and the breakdown of them, that one eventually would get a better understanding of the modern Jewish satellite housing communities and if they, infact, are the best solution to a cohesive community, and if not; what factors would enable the Jewish population in Jerusalem to develop communities that are cohesive.

Jerusalem is a city with many historical ethnic groups, districts, and urban villages which all have their own identities and territories. The following will touch on the Jewish population and their traditional housing. It should be noted that it is misleading to consider the Jews as one ethnic group. The Jewish population has ethnic groups within it including religious and non-religious groups from European and North African countries. But before examples and discriptions of various traditional Jewish neighborhoods can be shown and discussed, it is necessary to have a general background of the Jewish Quarter neighborhoods including their history, building forms, and listing of various elements which make up these traditional

neighborhoods.

For many years the walled Old City of Jerusalem could be compared to an island. It was the only area of development isolated among a vast wasteland consisting of hills strewn with rocks and scrub. The only linkage Jerusalem had with the outside world was by the Jaffa Road (which was really only a dirt trail) and other trails. The Jaffa Road was the main transportation route and it lead from the Old City to the coastal plain. At this point in time and up until the middle of the nineteenth century, the Jewish population in Jerusalem was concentrated within what was called the Jewish Quarter of the walled city.

The Jewish Quarter area was small with limited possibilities for expansion. There was overcrowding, and poor sanitation which caused epidemics. Along with the existing poor conditions, there was an influx of immigration which subsequently caused the Jewish population to buy land outside the walls and start building new settlements there. This all came about in the 1860's. Being desolate and far from the city, the land was sold quite cheaply to the Jewish people. (Kroyanker, p.17)

The first quarter to be built outside of the city walls, yet still remaining close to the Old City, was the Mishkenot Sha'ananim Quarter in the 1860's. By the year 1914, the Jewish population had established roughly seventy quarters, not all of which remained as close to the Old City as the Mishkenot

Sha'ananim Quarter. These quarters also varied in size and degree of importance, but certain aspects remained similar, such as: Intimate community life, the make-up of their population, and in administrative organizations which focused on land purchase and construction of new homes. These Jewish quarters started Jerusalem's neighborhood structure, and formed the beginnings of New Jerusalem. They were mainly built randomly along the Me'a She'arim road and the Jaffa Road and in time grew into one another and formed a continuous block of settlement. These neighborhood groupings produced large built-up areas, in contrast to the Muslim's private scattered building and the Christian's luxurious public and religious structures built for the thousands of pilgrims in Jerusalem. (Kroyanker, p.17)

A homogeneity was formed by the Jew's common religious, national, social, and economic background, habit of mutual assistance and developed community life. All of this leads to a great similarity in patterns of planning and construction. The Jewish Quarters were concentrated in two principle and three secondary areas and were distributed around the Old City on the north, west, and south in the form of a half crescent. (Kroyanker, p. 17)

The present differences between the quarters can be traced to the motives behind their establishment, the characters of their founders, the amount of funding at their disposal, and their initial character.

Bylaws for each neighborhood was drawn up in accordance with halacha, the system of Jewish law which governs every aspect of a Jew's life. The style of building around a central court was designed to accommodate Sabbath observance laws. A Jew may not carry objects from his private domain to the public domain on the Sabbath. They provide that the private domain consisted of houses facing a central court, thus allowing the residents to transfer things between their homes and the court, since the court is regarded as an extension of the private domain. Also, on the Sabbath, a Jew wasn't allowed to walk more than 2000 cubits (1120 meters) beyond the borders of his town. This worked fine at the beginning when the Jewish quarters could be built close enough to the Old City, but later, when the quarters were forced to build farther from the Old City, it was permitted to walk more than 2000 cubits beyond the quarter. (Kroyanker, p.22)

The placement of windows also fell under the halcha. According to the law it is forbidden to open a window onto a neighbor's courtyard. Most neighborhoods positioned the main window of the house on the opposite wall containing the front door. The main windows open onto the main street or public domain, to respect the neighbor's privacy, while the doorways face the central court. It is permitted though to have a window facing a neighbor's window when both windows open to the public domain. (Kroyanker, p.22)

Other neighborhood ordinances put emphasis on the importance of open public areas

and the planting of trees. The trees provided fruit and helped the Jews to get accustomed to working the land and ensure open green areas. Although these ordinances were established, only a small number of areas were planted. Most of the courtyards were nothing more than vacant lots. (Kroyanker, p.22-23)

Public cisterns were generally built before the homes were built, in order to have water available for the building. The water was channeled into the cisterns from roofs and stone-paved courtyards. Some quarters had separate cisterns for drinking water and for irrigation and bathing. Presently the cisterns no longer serve the residents of these neighborhoods and most of them have been sealed. (Kroyanker, p.23)

Building patterns were influenced by not only an economic factor, but by the need for security which provided defense and self-enclosure in the face of hostile surroundings, and a desire for a community life of mutual assistance. Topography and climate also were factors affecting building patterns. (Kroyanker, p.23)

Original building patterns were sometimes interrupted by the expansion of structures into place meant for open public areas and by the building of additions onto existing structures. The feature common to most of the buildings in these quarters is their inward facing orientation towards a central court. Private apartments were entered from within the compound, with the rear of the buildings facing the street.

A continuous wall was formed and was broken only by windows. Several types of courts were formed some being the following: Open courts with peripheral construction, enclosing an open interior court from all sides. The exterior walls served as a protective enclosure with one or more entrance gates. Built up courts were similar to open courts, but over the years had been filled with buildings not originally in the building scheme. Courts in front of a public building consisted of a triangular or rectangular court in front of a synagogue or study hall. This expressed the predominance of a religious structure surrounded by residential buildings. (Kroyanker, p.23)

One more planning scheme was based on an orthogonal grid of paths or lanes with houses constructed on the created plots. Still, some houses were built privately and independently with no overall planning involved. (Kroyanker, p.24)

One of the features of Jerusalem architecture is the use of stone which is a traditional regional practice. Its main characteristics are the variety of stone used, their colors, and the ways in which the stone is dressed and laid. This last characteristic is recognizable in the walls of the houses. The walls of the houses were generally 80-100cm thick and were constructed of three vertical layers: the exterior layer of light grey, brown or reddish brown stone; the middle layer consisting of a mixture of mortar and broken stone; and an inner layer of extremely soft stone used only for this purpose. (Kroyanker, p.38)

The dressing of the stone is categorized by the degree of roughness. Various types include:

Hami: square, undressed stone of varying size.

Tubze: rough convex dressing. Mainly used for the lower courses and cornerstones.

Taltish: medium dressed stone (smoother than tubze).

Musamsam: smoother than taltish, most often found as cornerstones and window lintels.

Mutabeh: finely dressed, with punctuate appearance, generally used in the interior surround of windows and doors.

Other architectural components include arch forms which were generally either roman, gothic, or horseshoe-shaped moorish arches (the latter being most common). Doors were narrow and modest in design. Building fronts for example, used a steady window-door-window pattern in some cases. (Kroyanker, p.38)

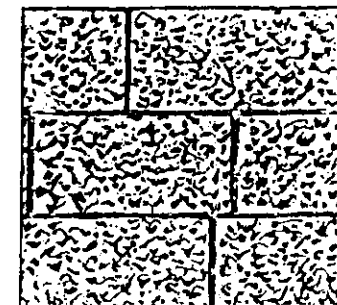
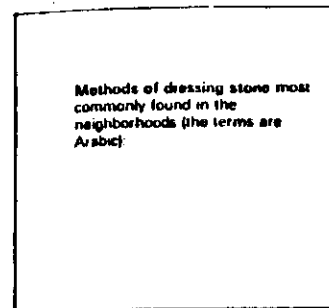

Taltish: medium dressed stone



Hami: square, rough stones, not of uniform size, and not dressed.

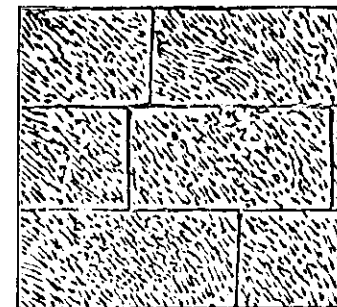

Musamsam: finely dressed stone.

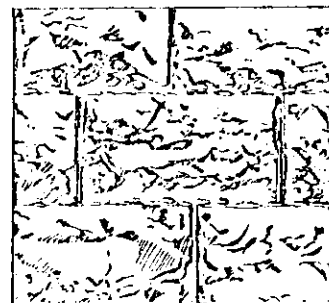

Tubzeh: roughly dressed, with convex face



Mutabeh: very finely dressed stone with punctate appearance.

(Kroyanker, p.39)

Courtyard entrances are usually high and narrow and have double doors of iron or wood, of which generally only one side is open. The already-narrow passageway is thus made narrower still. One door has a fixed, centrally-mounted handle; the other has an opening handle, part of a lock that has a large keyhole in it. A rectangular or arch window is positioned above the entrance, fitted with a grille (some being simple, others ornate). The forms of the iron and wooden doors are usually similar. Each door having three elements mounted on its face: an upper and lower rectangular frame and a central square frame. Their corners are rounded. There are also eye-shaped designs and other variations of greater or lesser degrees of ornamentation. (Kroyanker, p.38,41)

Windows are another important architectural component. Their importance includes not only the light and air they collect, but also a great potential for architectural expression. The proportions of a window's height to its width, the manner in which the stone along its edges is dressed, and the design of its grille and surrounding area are all of great importance. The form of a window has more potential than any of the other architectural elements to express economic or social conditions, whether the buildings house an open or closed society, and the nature of the climate. The double arched window is the most common in most of the neighborhoods. Sometimes their appearance is enhanced by the addition of a stone frame or an upper ventilation window. The window

frames are of wood and are simple in design. The grilles too, are unadorned. Most grilles are installed in the window apertures, and are recessed below from the external wall surface; but sometimes the grilles protrude slightly from the surface (this allows free observation from within). (Kroyanker, p.41)

Though most staircases are simply functional (linking a building's two stories), some have been given significance as a design element (the ends and center have an architecturally separate stairway, linking the lower floor to the continuous balcony which runs the length of the upper story). (Kroyanker, p.41)

Overcrowded conditions have caused additions to be created going against the original schemes of the neighborhoods. Balconies, designed to be open have been closed in to accommodate growing families. Balconies are supported on steel beams and add to a sense of disorder and improvisation. They also encroach on the already narrow alleys. (Kroyanker, p.41)

Many of the alleys were paved with square, rectangular, or very narrow flagstones, laid on compacting sand. This makes them easily cleared and maintained and resist the ravages of time and weather. Flooring in the houses was usually of square or rectangular flagstone. (Kroyanker, p.42)

Several of the building facades contain decorative metal stay anchors, which are installed at various intervals. Cables

are attached to these anchors to prevent the outward collapse of walls. (Kroyanker, p.42)

Now that the background on traditional Jewish neighborhoods has been given, it is possible to site various examples of some specific quarters visited by the author of this paper. The quarters to be discussed are the Mazkeret Moshe, Ohel Moshe, Batei Braude, Batei Rand, and Knesset Yisrael quarters. (It should be stated that the succat Shalom and Mishkenot Yisrael quarters are neighboring quarters to the others mentioned, but will not be discussed.)

The Mazkeret Moshe and Ohel Moshe Quarters are located in the northwestern sector of central Jerusalem, stretching south from Mahane Yehuda and Agrippas Street, and lying between Shomron Street on the east and Rafael Street on the west. The Mazkeret Moshe Quarter is an open-court quarter. It lies beside the Ohel Moshe Quarter, which has a built-up court. Both of these quarters have their original flat external facades, with the internal facades being broken up by sporadic unplanned additions. For example, Mazkeret Moshe's open courtyard has in it a kindergarten and a daycare center. Both quarters' cisterns have been capped off also. (Kroyanker, p.176)

The Mazkeret Moshe Quarter was originally built for Ashkenazim (Jews in the Diaspora [i.e. living outside of the Palestine and later Israel] from mainly Eastern Europe) and the Ohel Moshe being built for Sephardim (Jews from North Africa

with connections to Spain--strong Arab influence) in 1882. The buildings are arranged in a square, surrounding a large inner court which the houses face. The neighborhoods were organized as self-contained communities, sharing common public services: water supply, bakery, synagogue and children's religious school. (Kroyanker, p.176)

The Batei Braude, Batei Rand and Knesset Yisrael Quarters are adjoining courtyards of communal buildings. They are located in the western sector of central Jerusalem, north of Bezalel Street and Beit Ha'am on both sides of Hanatziv Street. These neighborhoods were built adjacent to one another over a period of years. They are built around open courts, with a typical synagogue built on one side of each court. Some of the buildings have decorated gates opening onto underpasses, from which the courtyard may be entered. There are also latrine towers at the ends of the residential houses. (Kroyanker, p.193)

The construction of Knesset Yisrael was started in the 1890's, with most of the building being done in the early twentieth century. This neighborhood was built for Ashkenazi. The quarter is designed as a rectangle with the east side left open. Its one-story houses were built side by side, to give maximum utilization of the available land. Its central institution was the synagogue, which is about a half a meter taller than the other buildings. Seeing that there were no schools built here, the children were sent to nearby Mazkeret Moshe. (Kroyanker, p.193)

The Batei Braude Quarter was built in 1902-3 by memorial trusts. The charter of the trust notes that the houses are for religious scholars who pray according to Ashkenazi liturgy. In 1909, the Batei Rand neighborhood was built to the east of the Batei Braude neighborhood from another memorial trust. This neighborhood is similar to Batei Braude; its central building contains 21 apartments on two floors, and there is an elaborate entrance gate. A two-story building housing public baths was added later. (Kroyanker, p.193)

Some characteristics I observed while studying these neighborhoods are similar to each other. The quarters are all inward looking. Most of their main windows and their main entrances are all located on the interior of the development. This creates an almost fortress-like condition. Since the quarters are situated directly next to each other, the circulation between the quarters becomes "streets of walls" (which are essentially the backs of the houses). This also creates a micro-climatic condition. Most of the buildings are two stories. The synagogues (which are usually located in the center of a quarter) are normally three stories, thus portraying a sense of dominance and significance within the community. The intimate scale of the buildings also gives a sense of individual presence. To enter one of the quarters one must enter one of the ever-present gateways. (As noted earlier in this paper, these gateways were developed for security reasons and one could say they were also used to help define the individual quarters.) Once at the interior

of a quarter, one notices the hierarchy and sequence of open spaces. The courtyard, which is surrounded by dwellings, is the most public of the spaces. This is where all of the public interaction takes place. Even though the cisterns are all capped off, these spaces are still the social spaces they used to be. The women of these quarters hang their laundry here and the courtyard becomes a place for social gathering. Kindergartens and daycare centers now also occupy the courtyards. They are usually fenced in with play areas and allow for an interaction between the children and the older members of the neighborhood. Surrounding these fenced areas is a perimeter public circulation space. As one moves further outward the next spaces are the semi-private spaces of the individual courtyards. These courtyards, used by the individual families, are more private atmospheres than the public area of the main courtyard. They directly precede the last level of the hierarchy-- that of private space. The most private of the spaces are the individual dwellings. Most of these dwellings were two stories. When they were first constructed they were all one story. When additional space was needed, the families would build a second story and sometimes build within their own individual courtyard if possible.

Existing balconies were later converted into additional interior spaces also. It should be noted that none of these additions exceeded two stories. More recent additions that have been made have been made in a sort of hodge-podge manner. Foreign materials such as corrugated aluminum have been used instead of the typical

stone. Although these later additions have basically been applied with no thought of making them an integral part of the existing dwelling, there is a great sense of individuality and spontaneity with these additions.

Through the use of this written text on the history of the traditional Jewish Neighborhood, the examples cited and the various illustrations; it is hoped that one would get a better understanding of one of the many ethnic neighborhoods that exist amongst the many other ethnic neighborhoods that exist amongst the many other ethnic groups in the city of Jerusalem. All of these various groups have their own housing identities and by understanding one of these, one can then start to compare this one group to the others that exist and get a better understanding of just why Jerusalem is such a mosaic of building concepts which were enchanced by the diverse ethnic traditions there. All of the ingredients for a sense of community and environmental cohesiveness are present in the traditional neighborhoods. By studying the breakdown of these elements; criteria and guidelines for the conservation of these elements and the development of new communities using the criteria and guidelines developed would be possible, thus creating a higher sense of community and cohesiveness which I feel is lacking in the neighborhoods of Jerusalem at present.

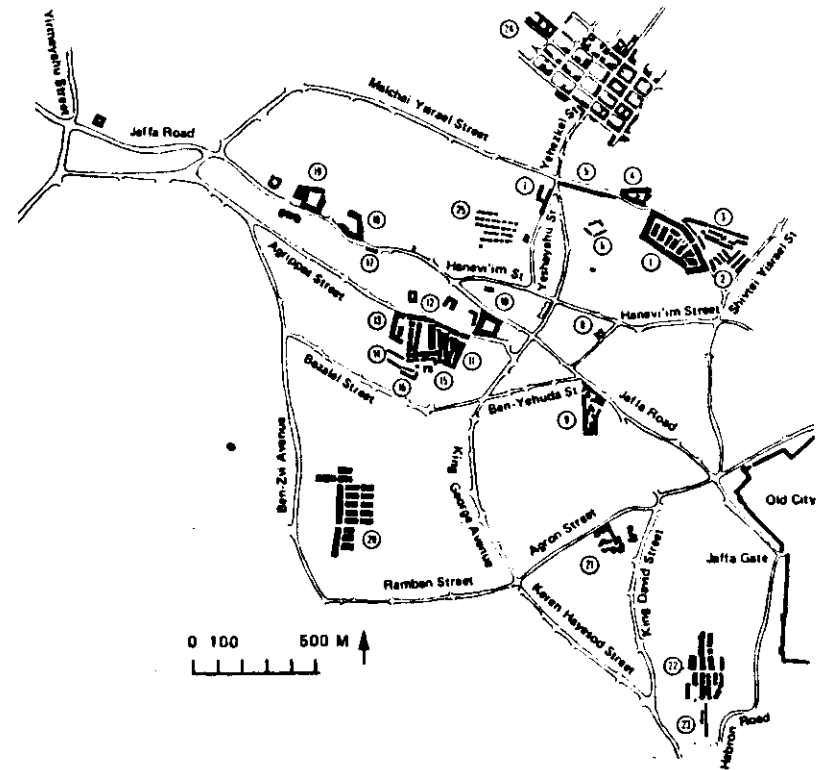

#### THE MOST TYPICAL QUARTERS

1. Me a She'arim	1874
2. Batei Ungarn	1891
3. Batei Nerim	1903

#### TYPICAL QUARTERS

4. Nahalat Zvi	1894
5. Batei Varsha	1894
6. Sha'arei Moshe	1888
7. Batei Orenstein (including Wolyn)	1898
8. Beit David	1873
9. Nahalat Shiva	1869
10. Even Yisrael	1875
11. Mishkenot Yisrael and Succat Shalom	1876/1877
12. Markeret Moshe	1882

13. Ohel Moshe	1883
14. Batei Braude	1902
15. Batei Rand	1910
16. Knesset Yisrael	1902
17. Beit Ya'acov	1878
18. Ohel Shlomo	1891
19. Sha'arei Yerushalayim	1891
20. Sha'arei Hessed and Nahalat Tzadok	1908
21. Mahane Yisrael (the Mughrab Quarter)	1868
22. Yemin Moshe	1891
23. Mishkenot Sha'ananim	1860

#### EXCEPTIONAL QUARTERS

24. The Bukharan Quarter	1894
25. Zichron Moshe	1906

(Kroyanker, p.19)

**ANALYSIS**

---

This quarter is a typical example of an open court style of planning. It is an inward facing scheme with gateways that separate the neighborhood from the outside surrounding areas (for security reasons mainly).



FOUR MAIN ZONES

- Public
- Semi-public
- Semi-private
- Private

BREAKDOWN

- Zoning
- Public space
- Circulation
- Private courts
- Residential Layout

**ZONING**

-  - Public
-  - Semi-private / Semi-public
-  - Private

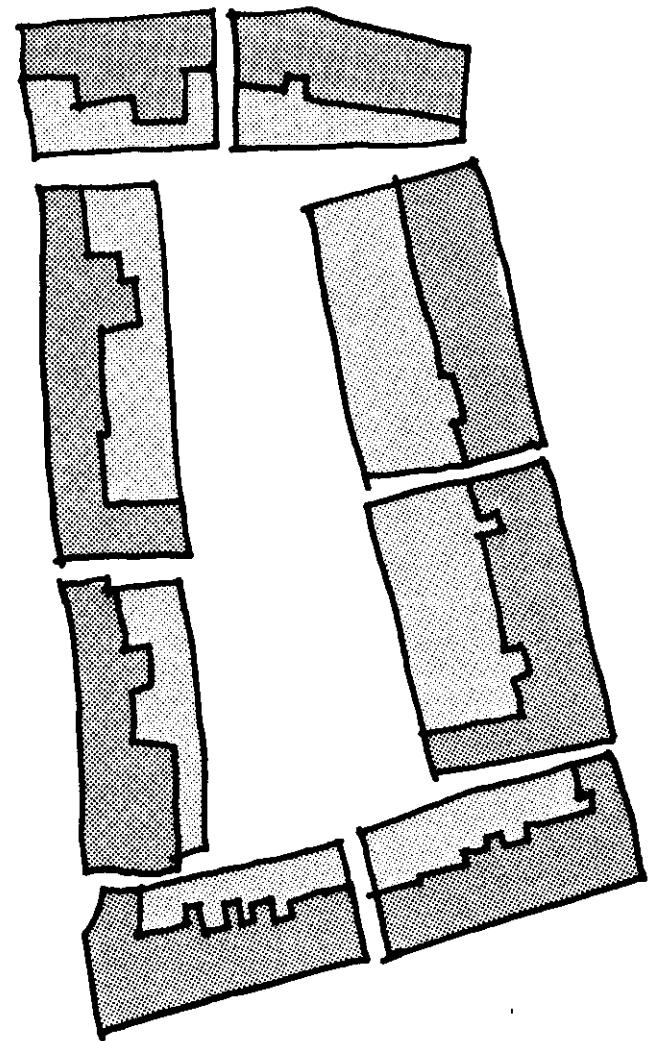

- 1/ Open, public meeting space. Community interaction takes place here.
- 2/ Enclosed courtyard. Enclosed by surrounding residences, public buildings.
- 3/ In some cases, schools and educational elements occur here -- adds to life/vitality of community (i.e. children, activities).

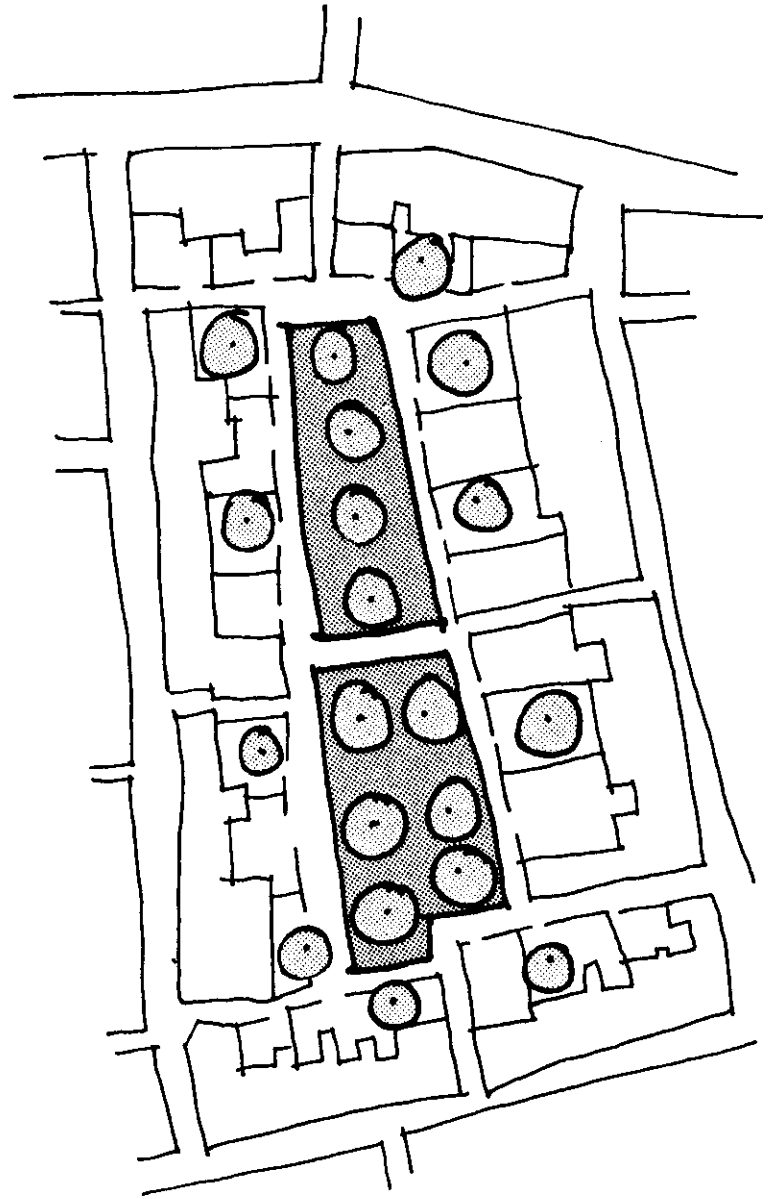

- 1/ Entrance to community: entry to the "neighborhood" is through one or more entrance gates that can be closed off at night for security/privacy reasons.
- 2/ Leads to community public space. This is the first step in the sequence to getting to the private residences.

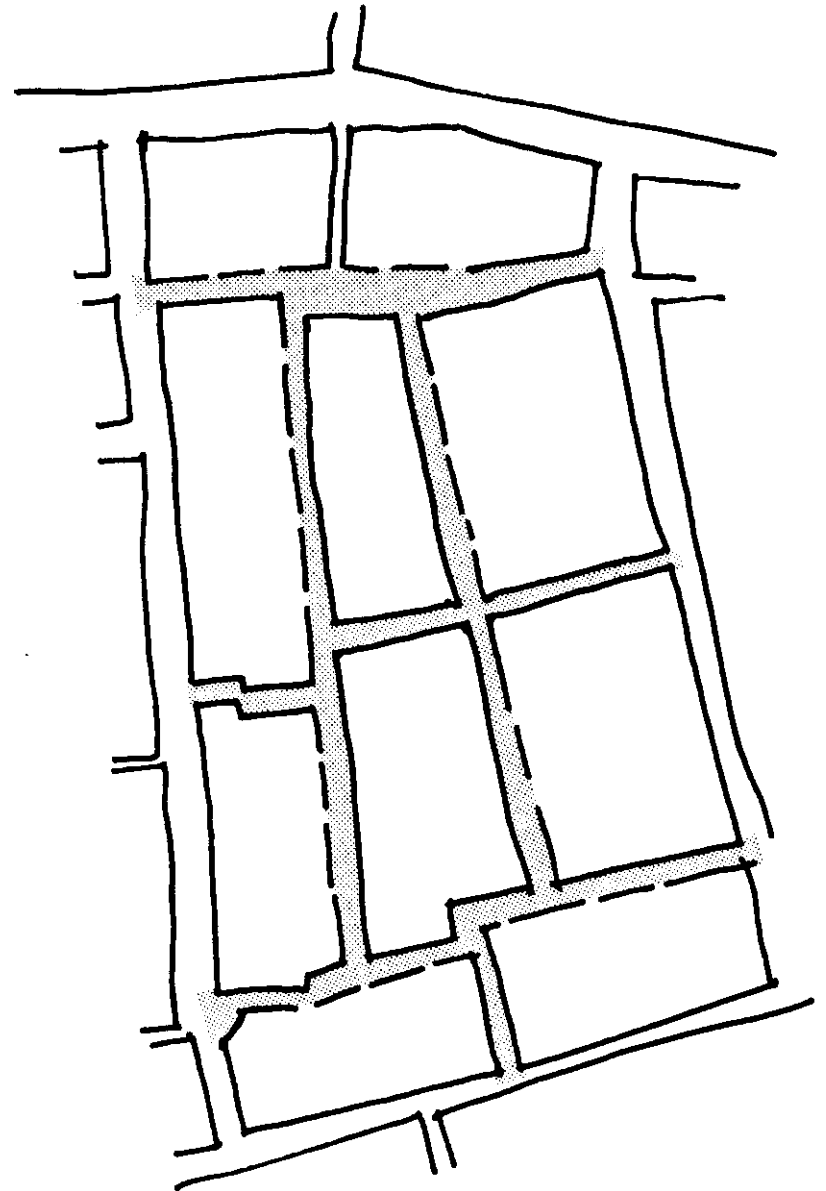

- 1/ Serve as a part of the sequence and organization of entrances to private apartments. Namely the access/egress which is the second step in the sequence to the private residences.
- 2/ Gives separate residences privacy. Buffer zone between the private (residence) and the public (community space).
- 3/ By this sense of privacy/separation and the breakdown of the public court at this level, an individual identity is developed.

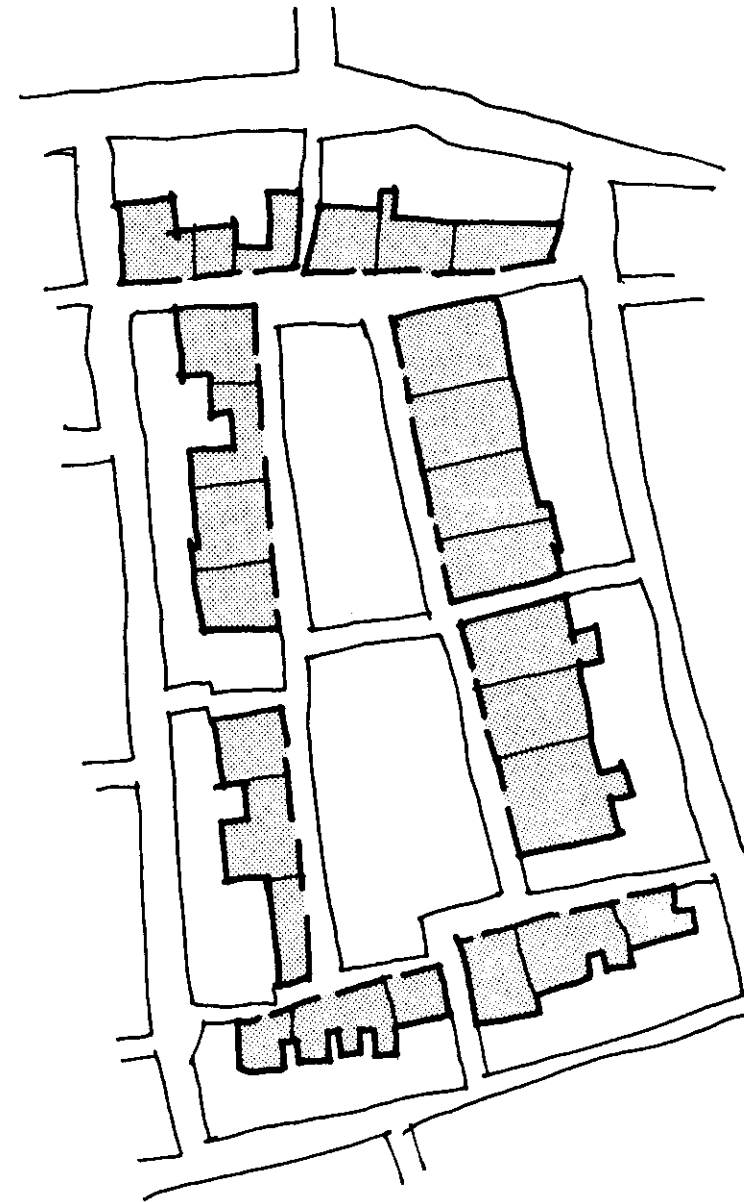

- 1/ Open court: peripheral construction, enclosing an open interior court from all sides. The exterior walls constitute a protective enclosure with one or more entrance gateways.
- 2/ Entrance to residence: no entry from street side, one must enter through gates proceeding then to a private courtyard before entering main dwelling entrance.
- 3/ Residential layout: low rise buildings (adjacent to ground) have ability for growth/extendibility (i.e. personal expression).

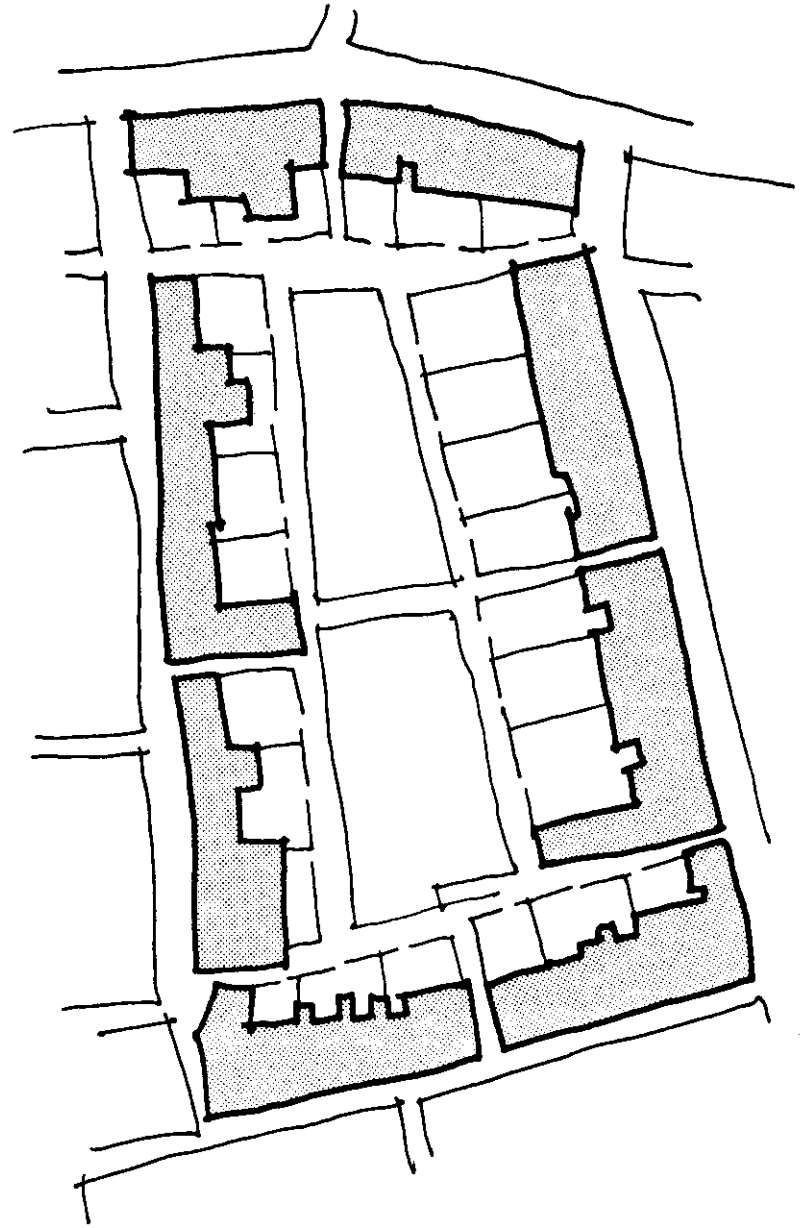



Characterized by communal row houses built around a series of typical courts with an upper level of circulation running around the inside perimeter of the neighborhoods. Latrine towers, water cisterns, entrance gates, and trees occur within these courts, as well as synagogues which act as important focal points in these neighborhoods.

BREAKDOWN

- Zoning
- Public spaces
- Circulation
- Public buildings
- Residential layouts

**ZONING**

-  - Public outdoor spaces
-  - Public buildings
-  - Private

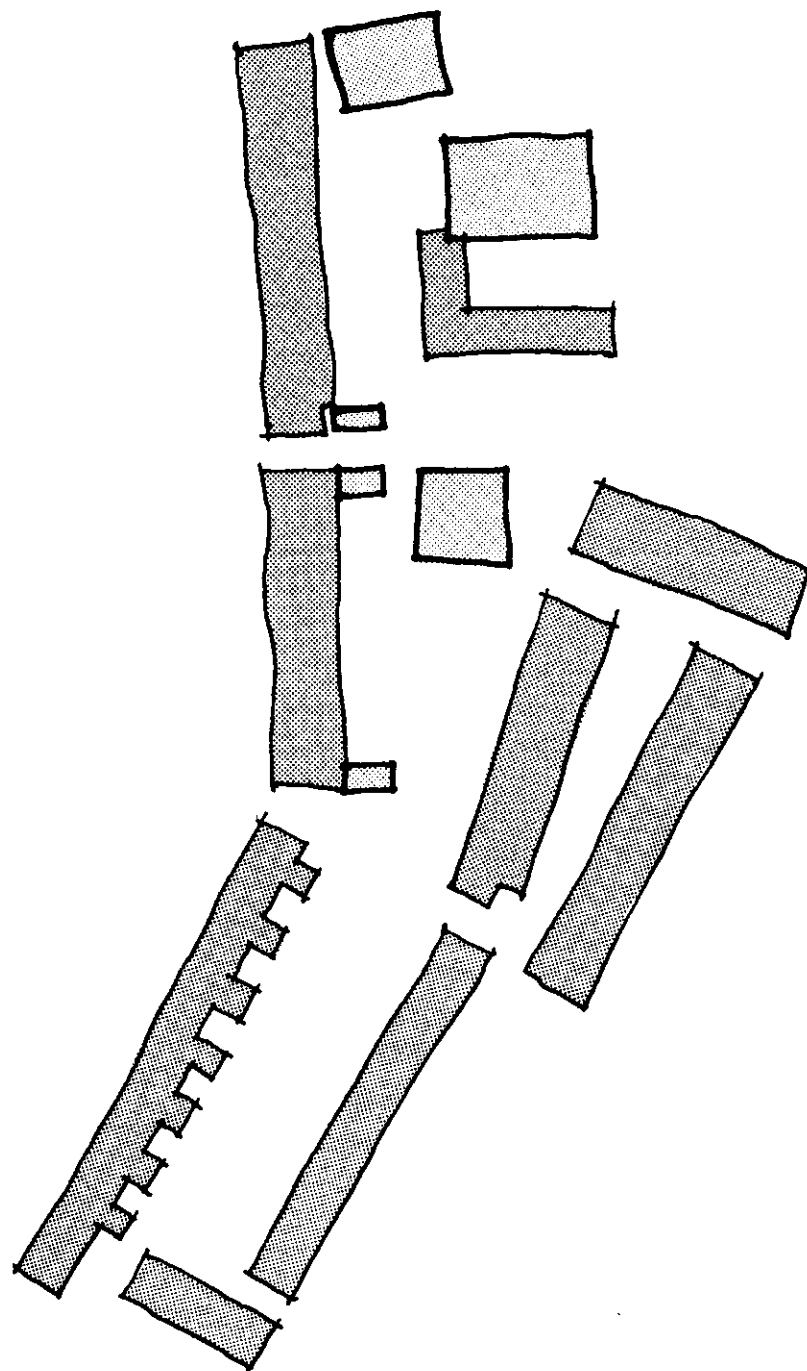

- 1/ Open, public meeting space. Community interaction takes place here.
- 2/ Series of connected courts (paved/landscaped).
- 3/ Public buildings occur here: synagogue/ kindergarten adds to vitality of community.

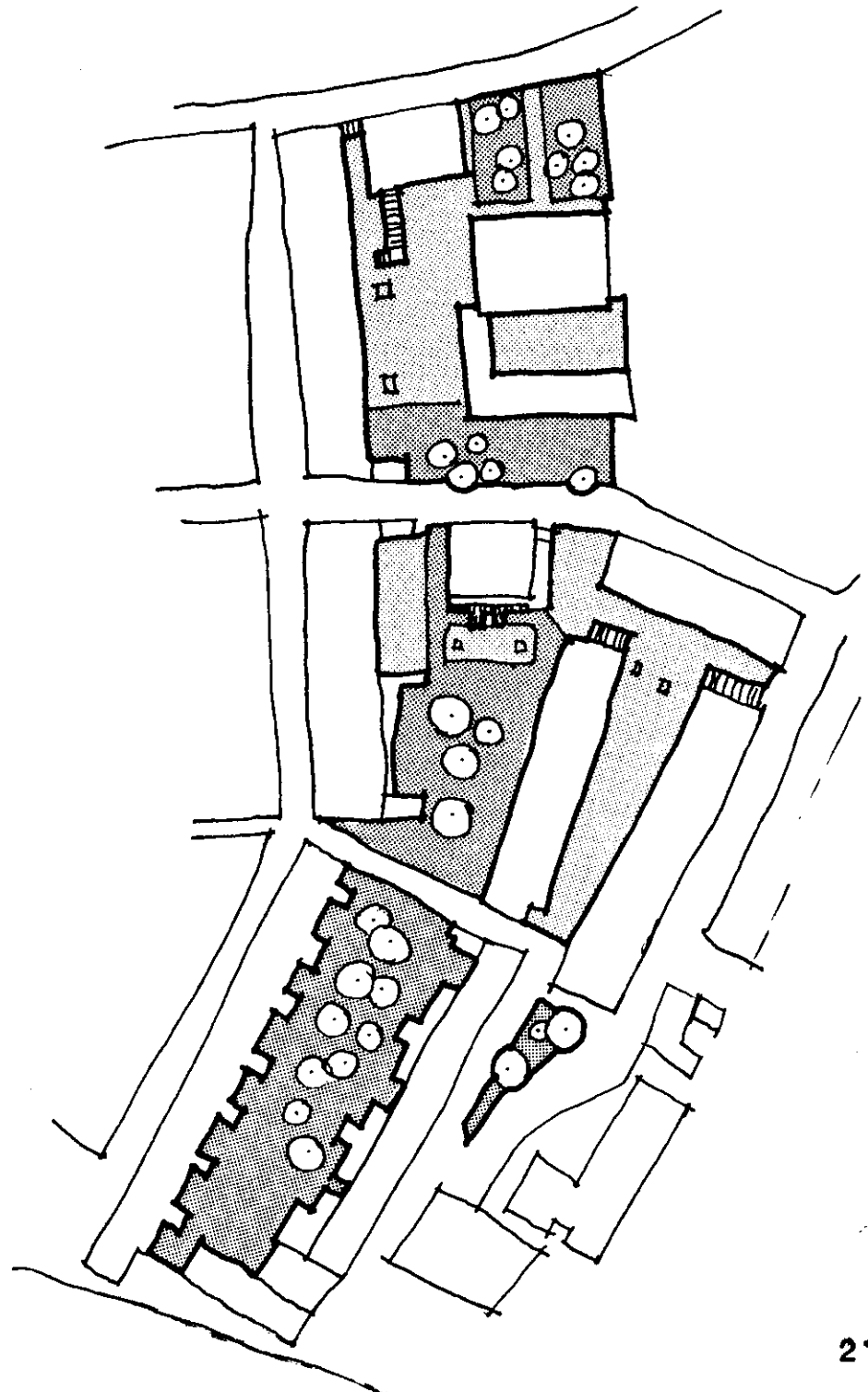

- 1/ Main circulation: separates the three connecting neighborhoods, provides a direct pathway through neighborhood, and leads to the courtyards.
- 2/ Upper circulation: occurs by continuous upper walkways of second story dwellings and acts as a connector of dwellings.

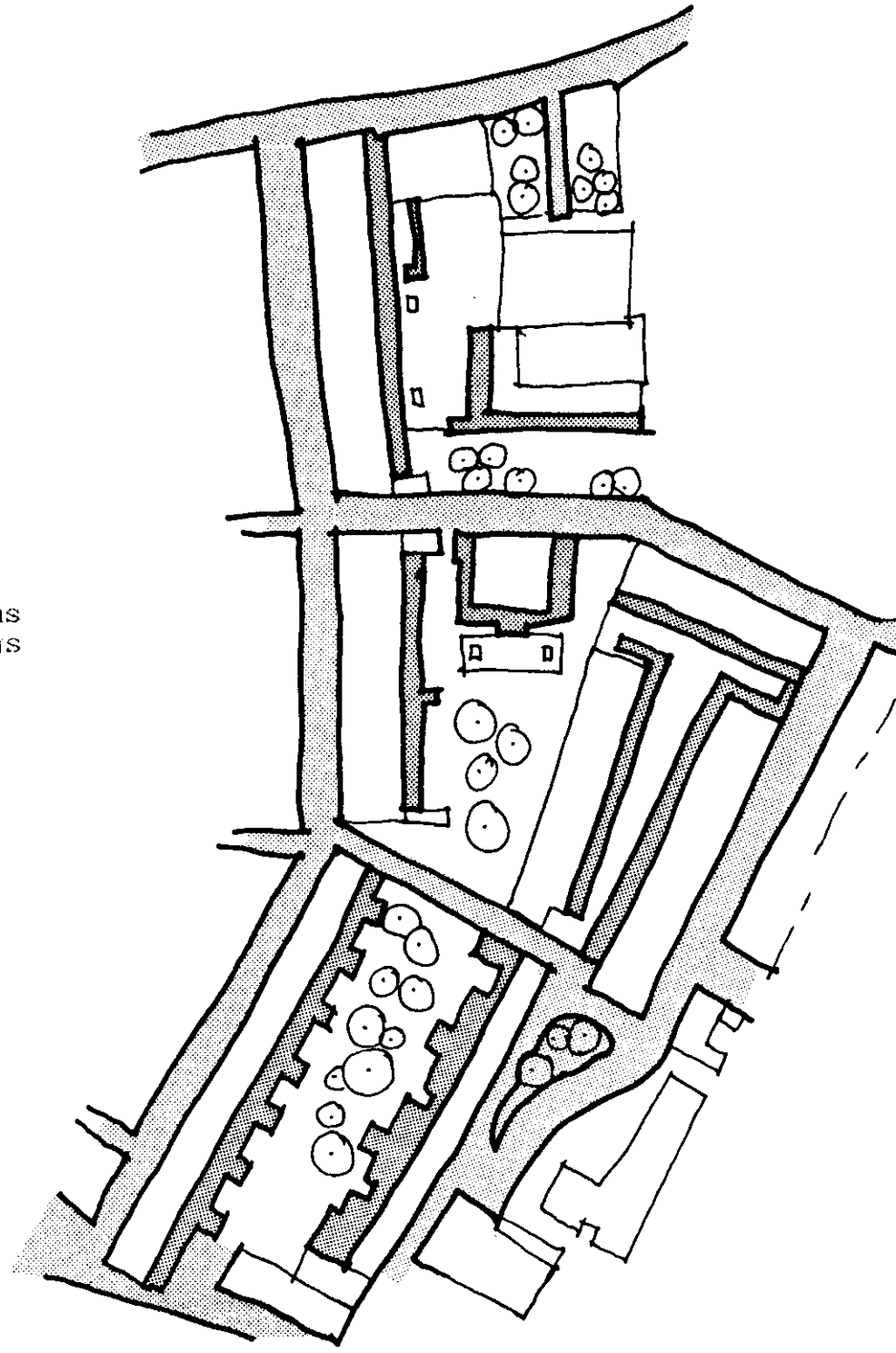

- 1/ Serve as focus of neighborhood.
- 2/ In this case the synagogue draws people from all three neighborhoods-- puts community interaction on a higher level (kindergarten/schools would act in same way).
- 3/ Latrines: now modernized to facilities in each home. They acted as a public building.

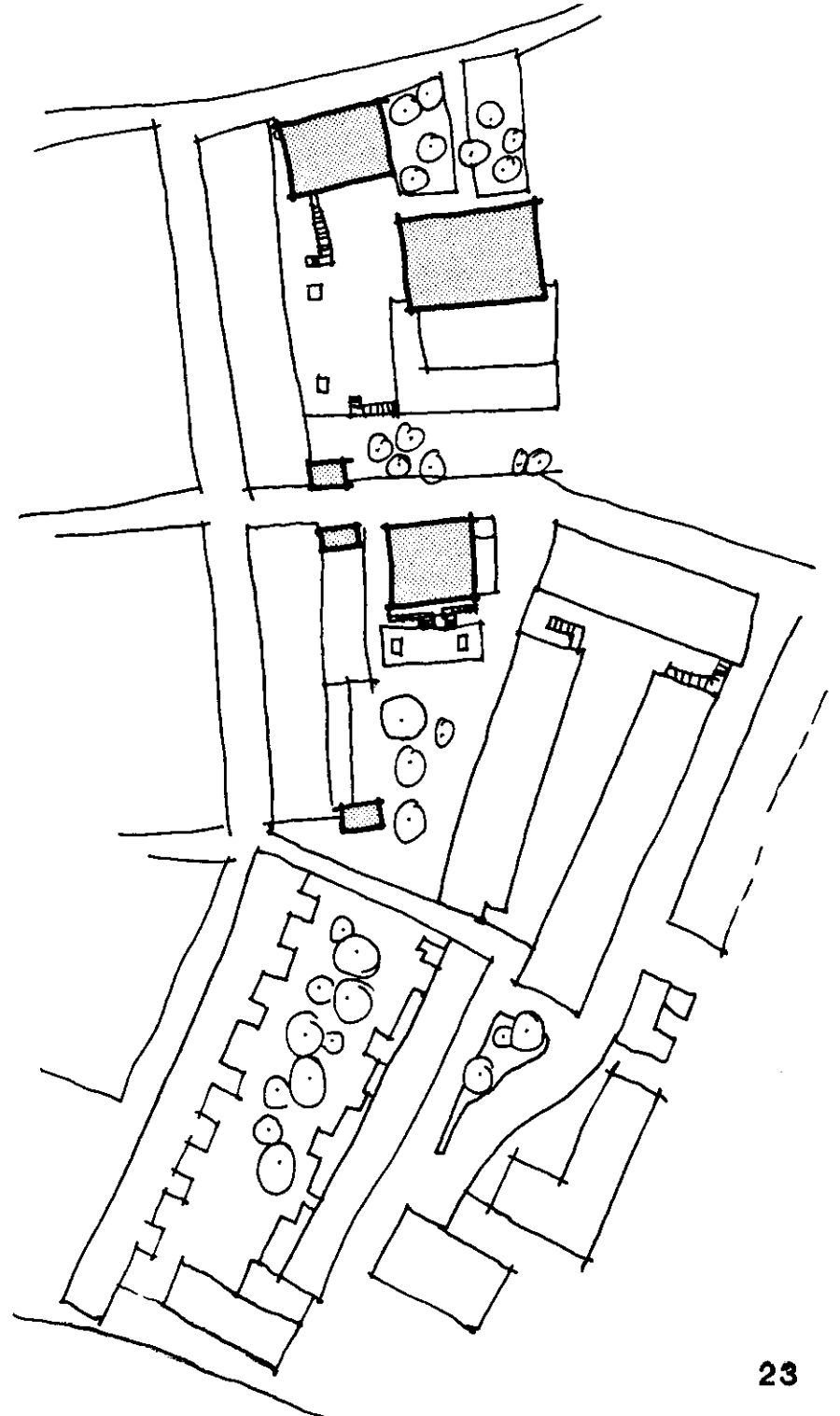

- 1/ Most private zone of neighborhoods.
- 2/ Create linear walls to separate from outside neighborhoods.
- 3/ None or little use of private courts. Entrances on courtyard side directly accessible from public space, no buffer zone.

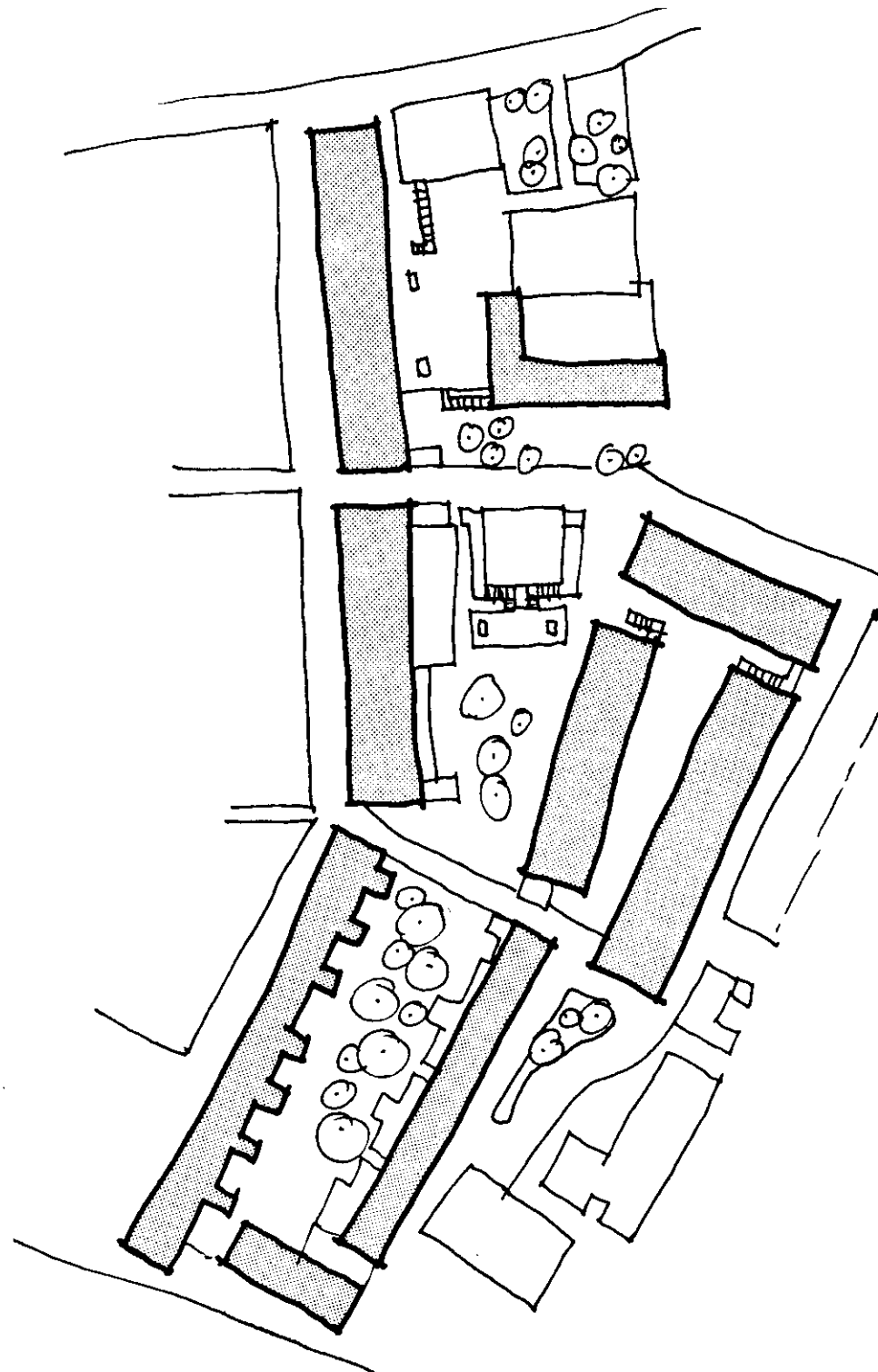

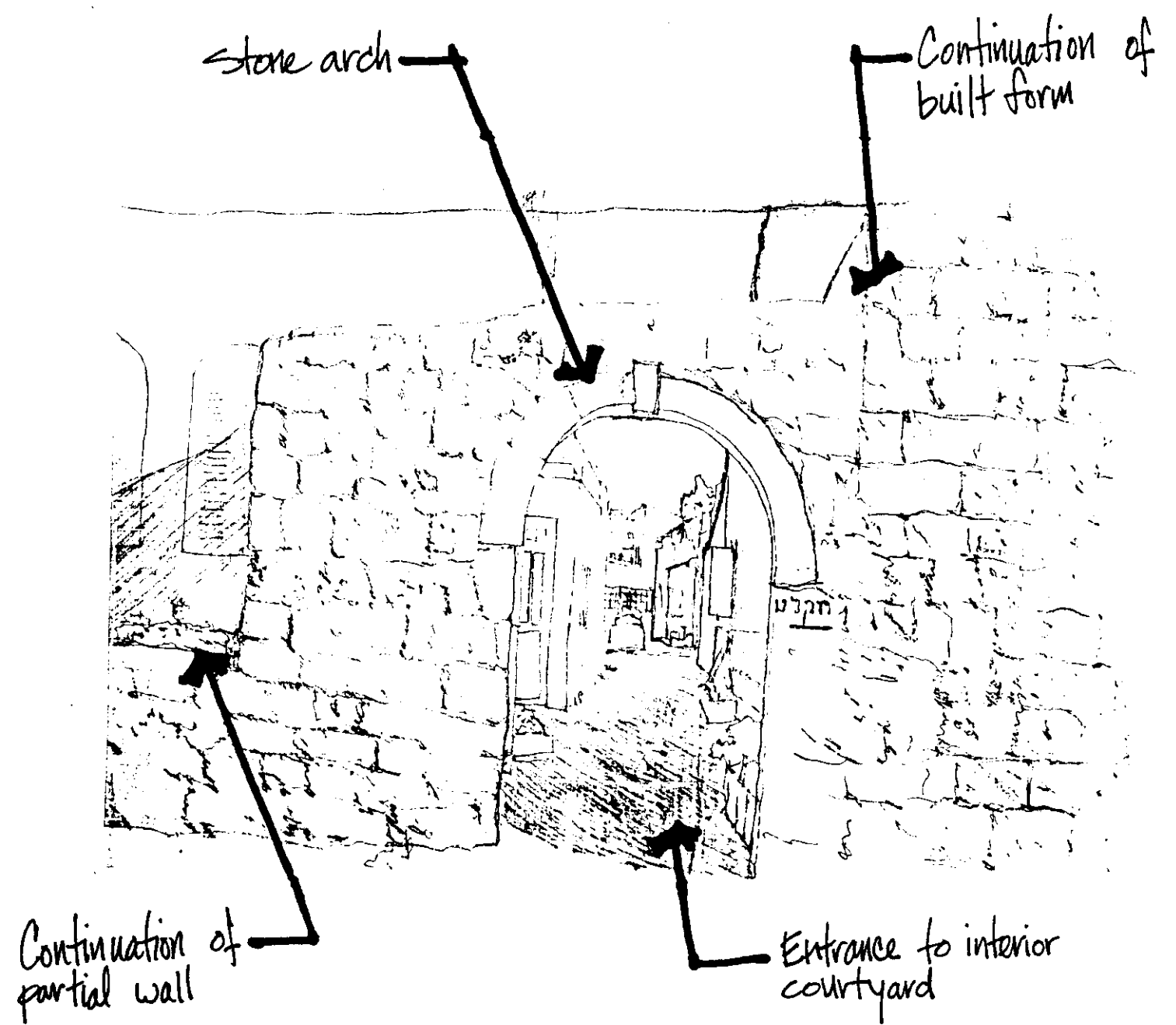

WINDOW TREATMENT-- TRADITIONAL NEIGHBORHOOD, JERUSALEM

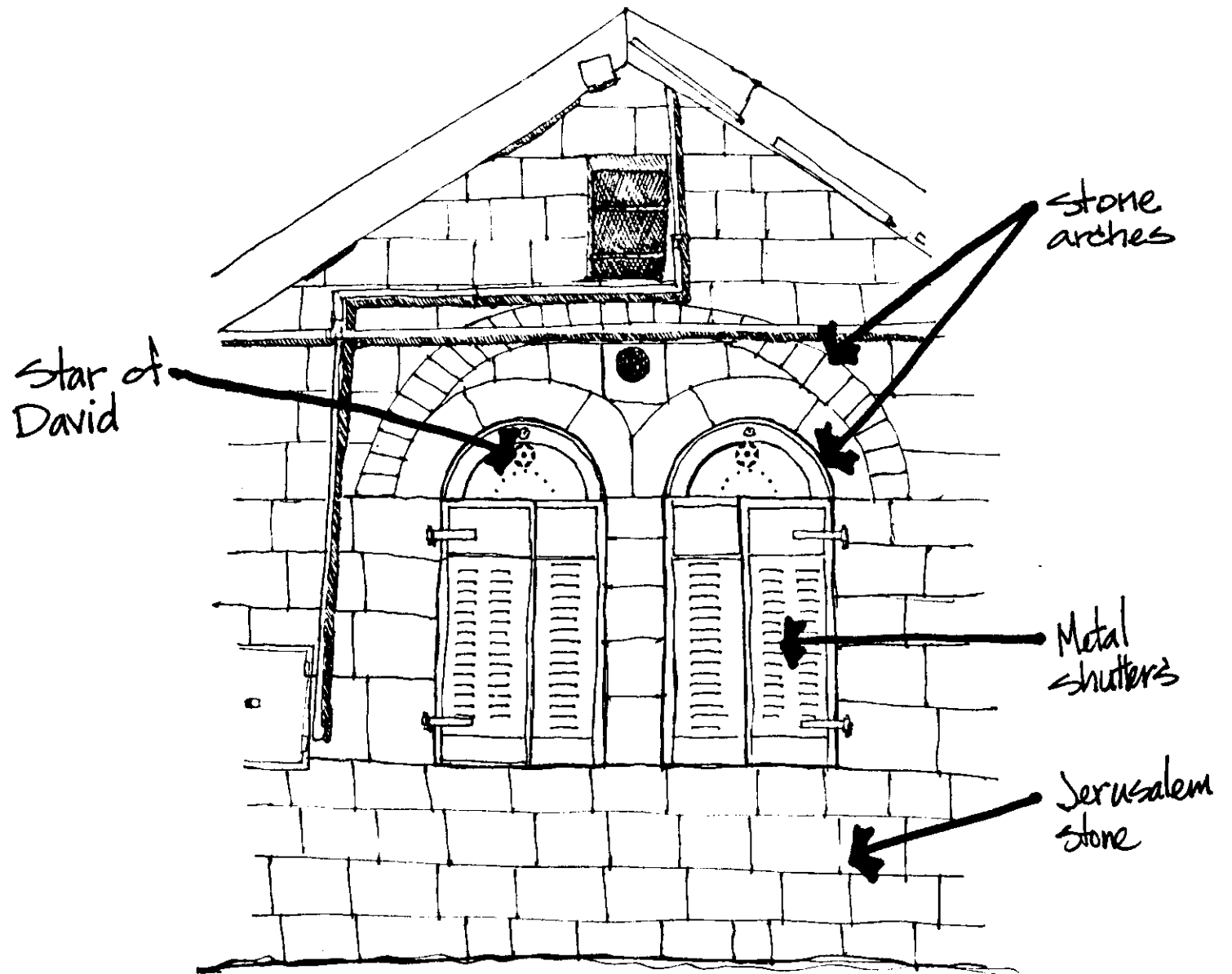

SIDE STREET-- TRADITIONAL NEIGHBORHOOD, JERUSALEM

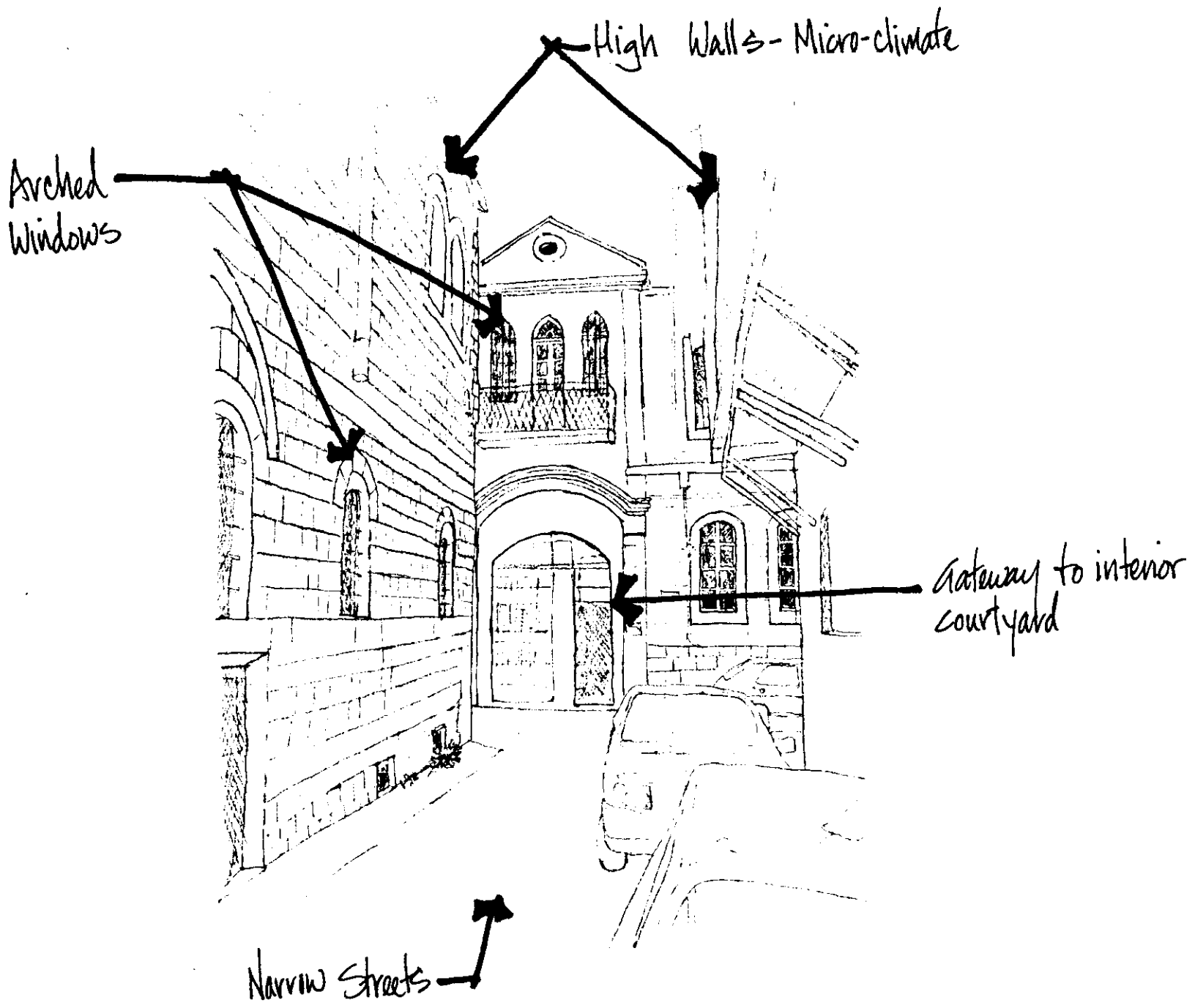

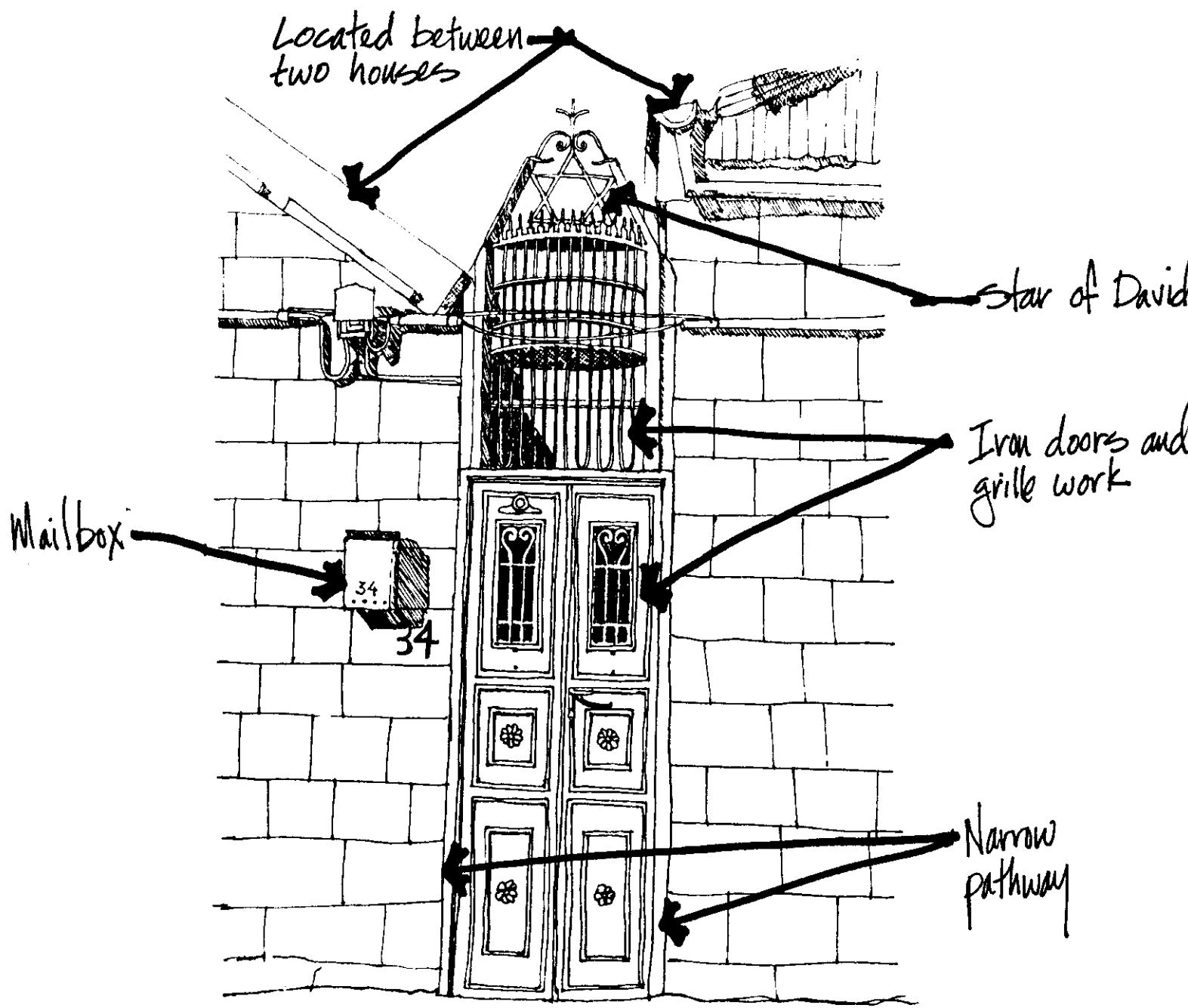

1/ In an Abyssinian Quarter high garden/courtyard walls enclose the individual houses (many with a tree in the inner courtyard). The walls define territorial boundaries while also creating private streets with a micro-climate.

2/ A typical scene within a courtyard of a neighborhood is laundry being hung out to dry. This acts as a social climate for neighbor interaction.

3/ There are contrasts between traditional housing and mass built housing (after the Yom Kippur war). Even though the traditional housing is older, it looks newer. It has more character than the mass housing (slum-like) and is made from stronger and longer lasting materials such as stone.



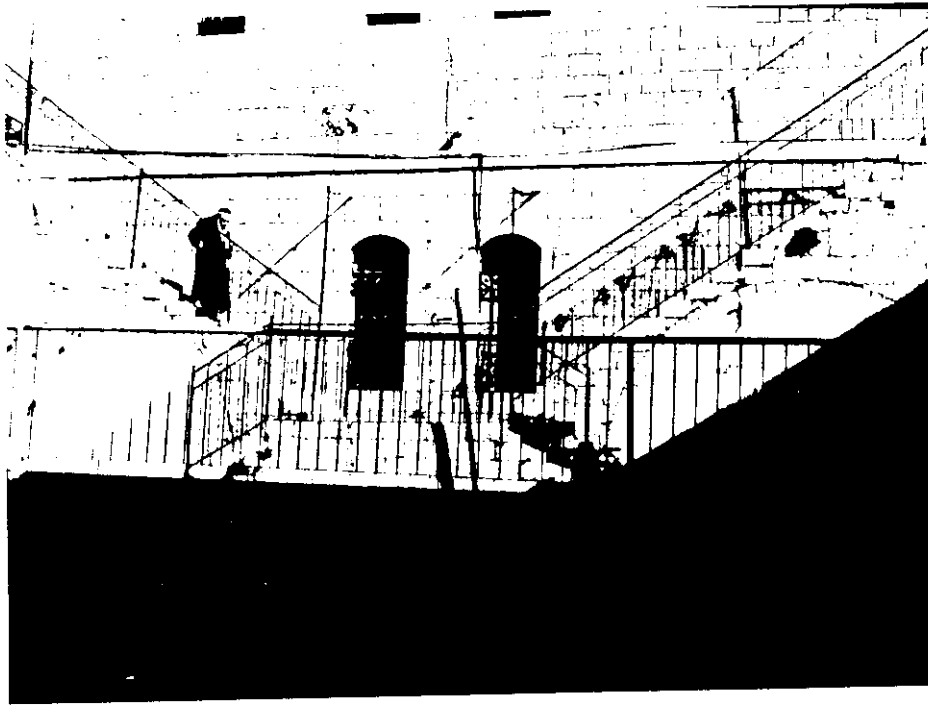

In this neighborhood perimeter blocks are used to define the difference between public and private exterior spaces. In concept it is similar to a traditional neighborhood. The most public spaces are at the extreme exterior of the development, the actual dwellings acting as the "walls" around the neighborhood. One passes through a gateway to get to the interior of the neighborhood. The center courtyard is used in a somewhat different manner than the traditional. Instead of being a place to gather as in the traditional, its main function in this neighborhood is for a parking lot. The hierarchy of spaces at Ramot is somewhat similar to the traditional with a few exceptions. The semi-public central court leads directly into the most private area, the individual dwellings. Semi-private terraces are located at the outside perimeter of each block. There is a pedestrian axis defined by the two perimeter blocks which links the projects to the center of the neighborhood as well as to adjacent neighborhoods.



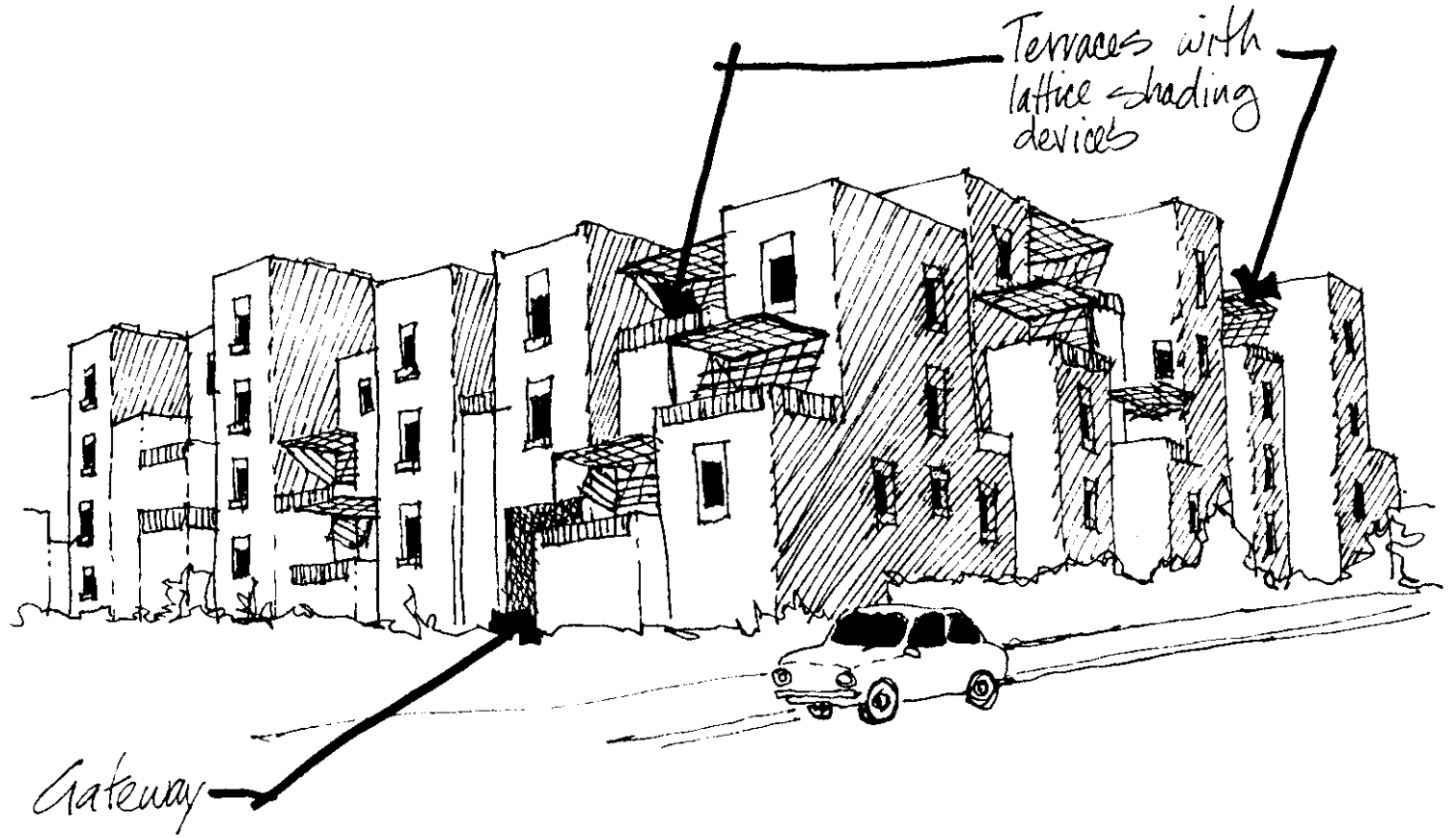

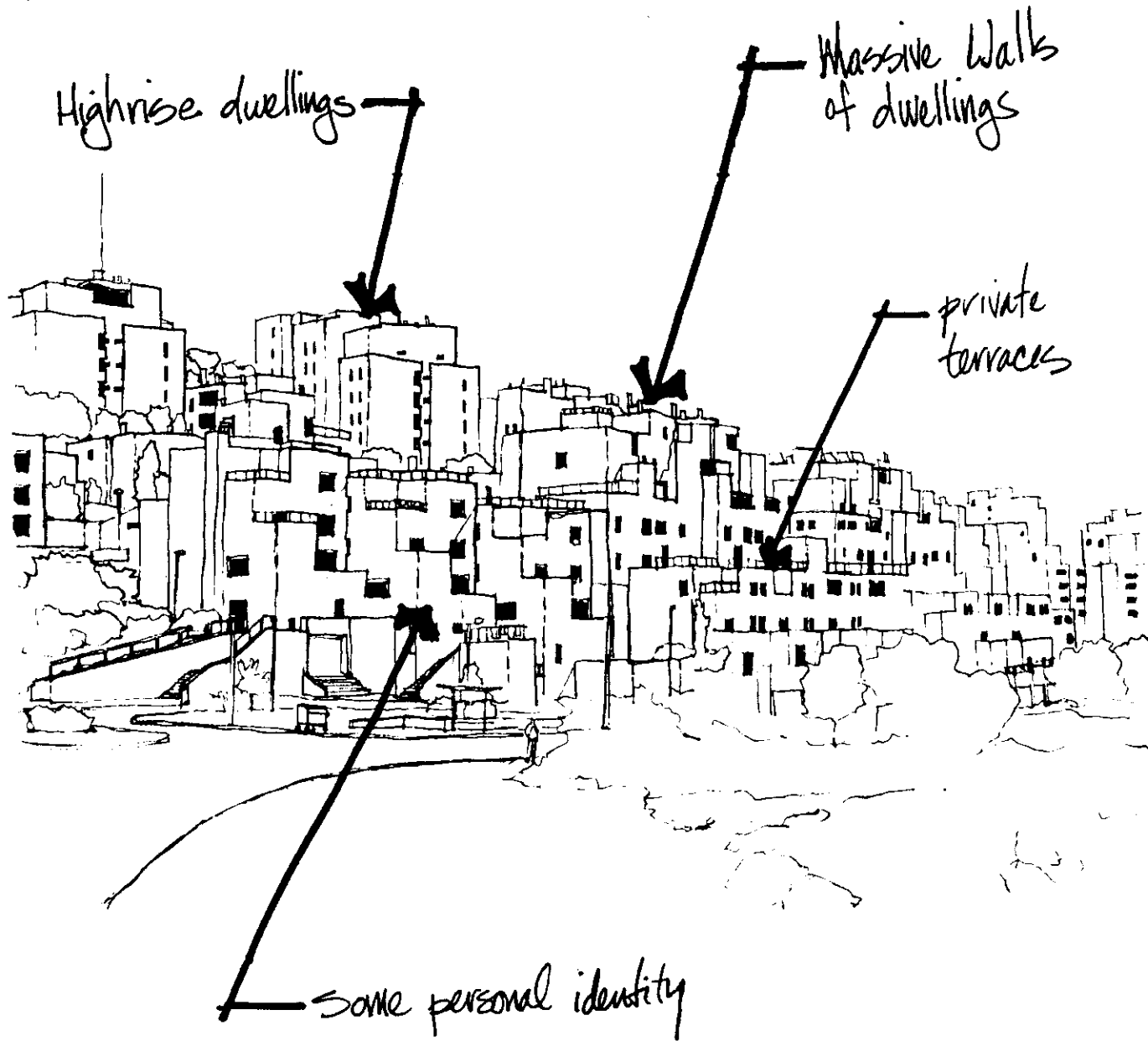

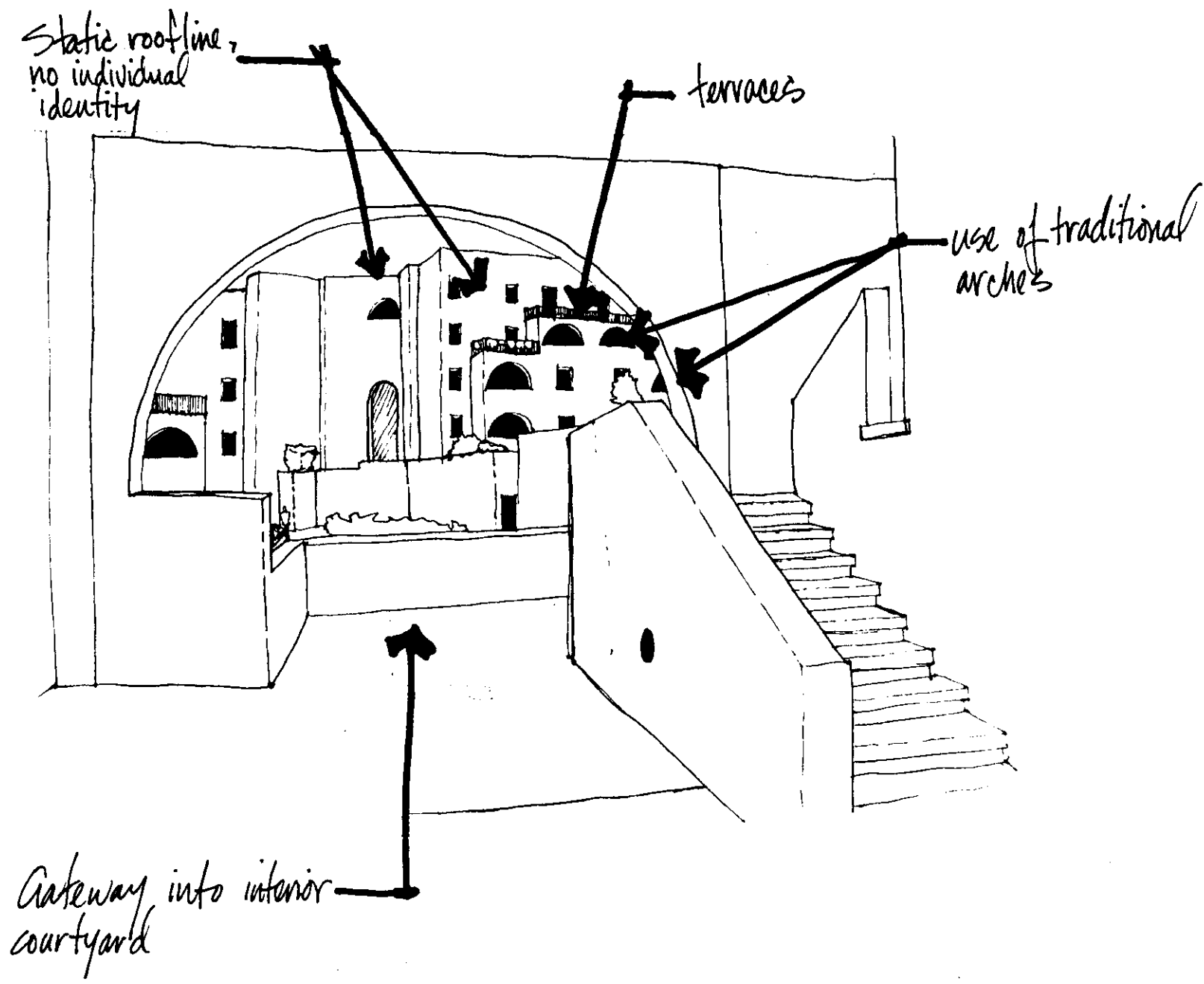

COURTYARD-- MODERN HOUSING COMMUNITY, JERUSALEM

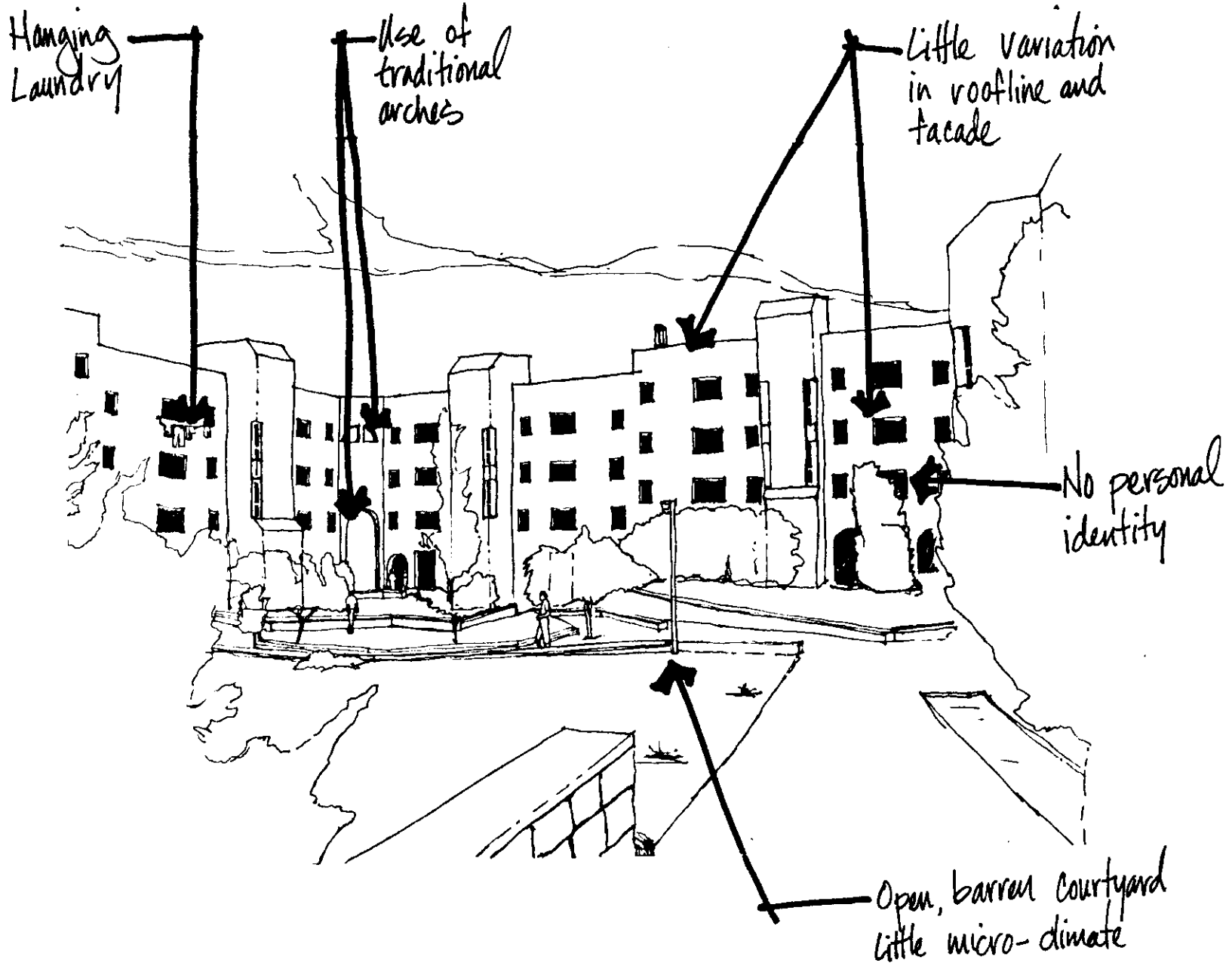

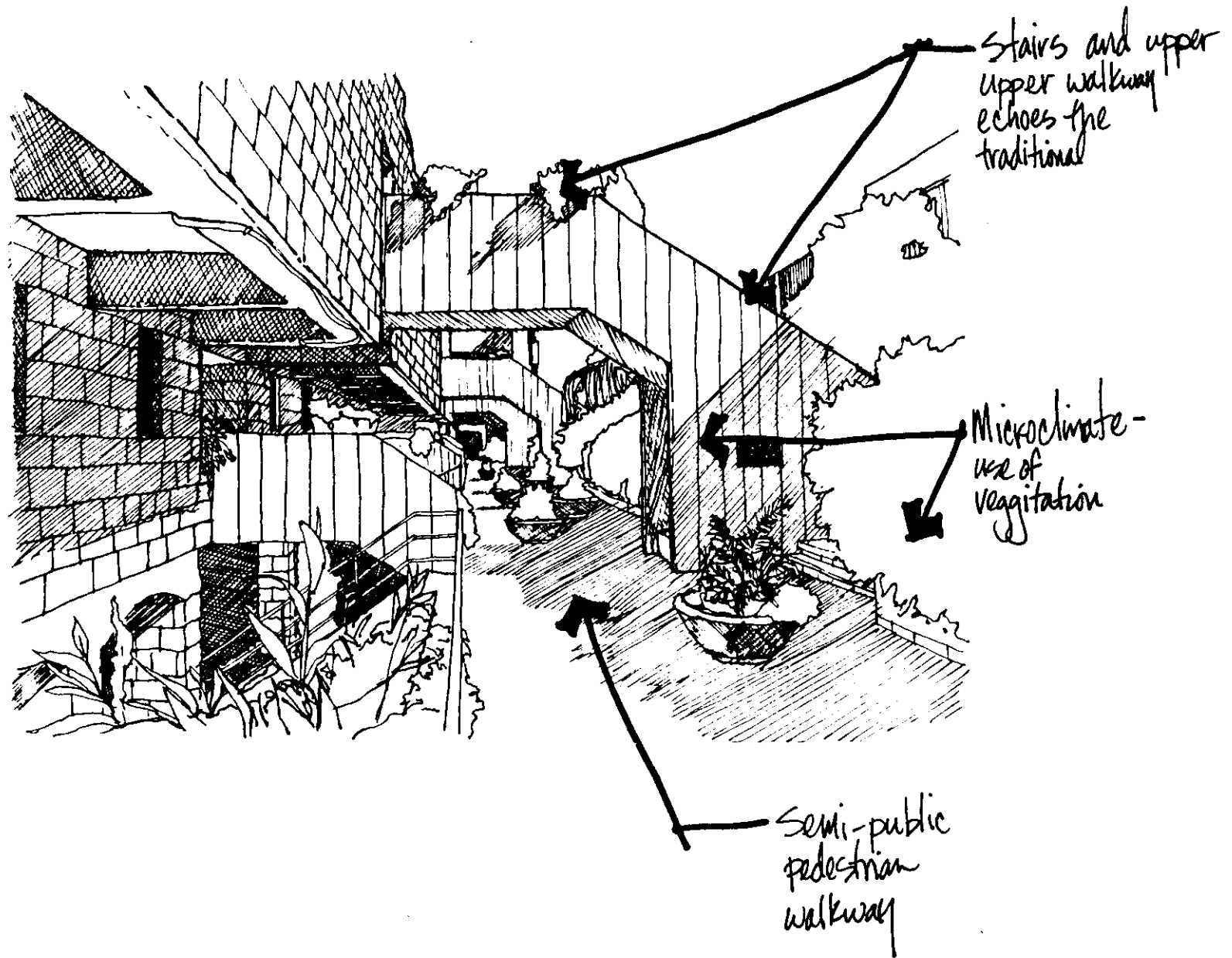

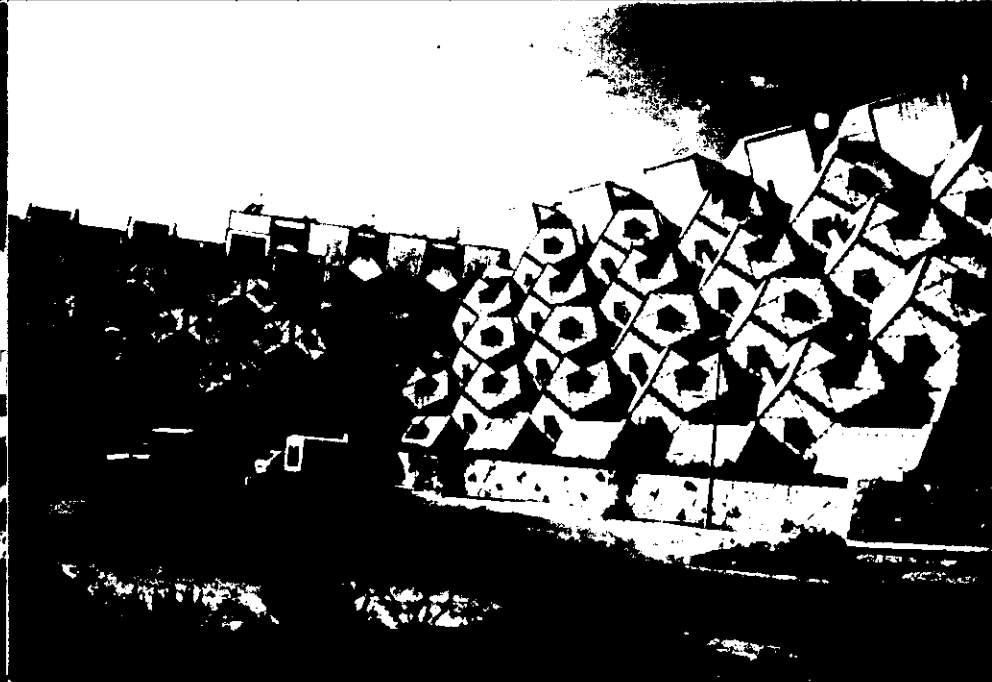
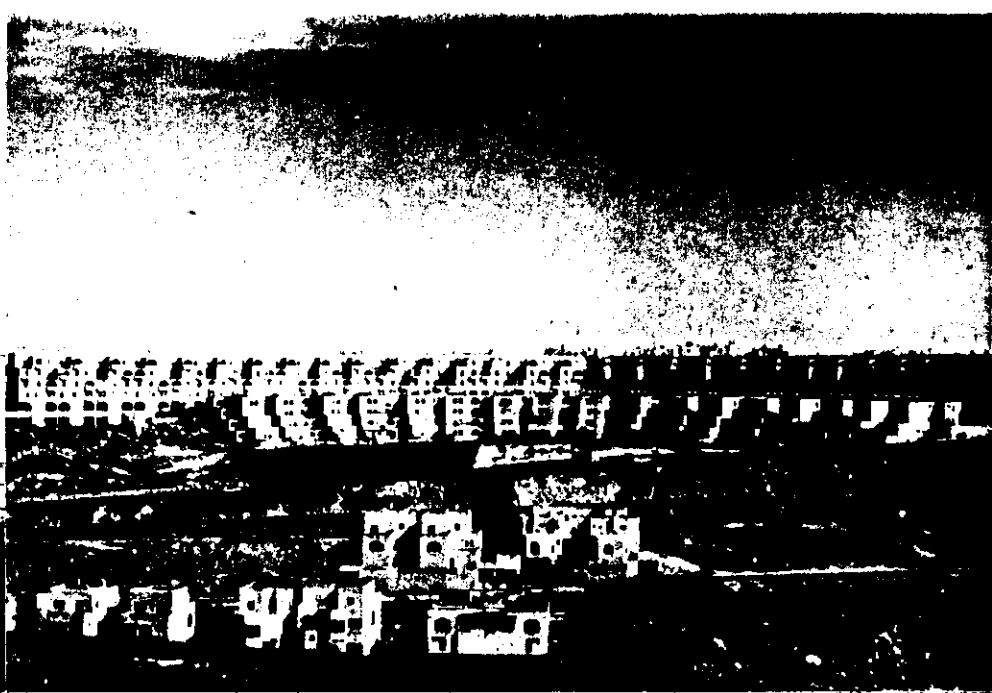
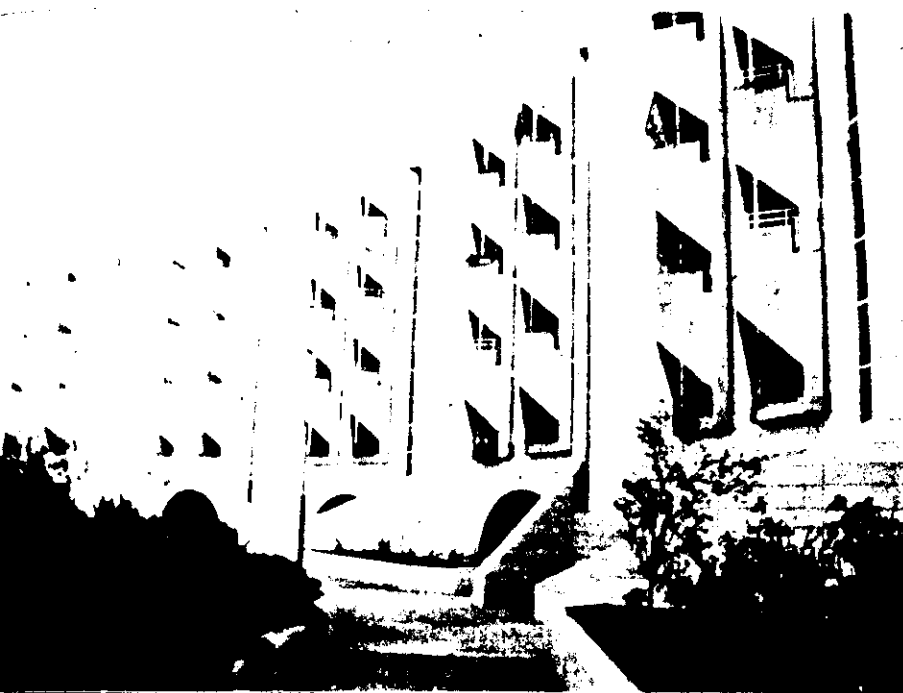

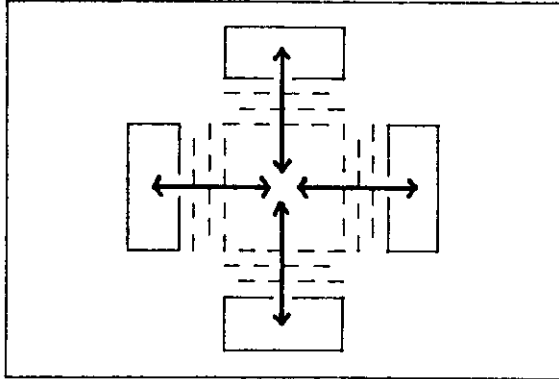
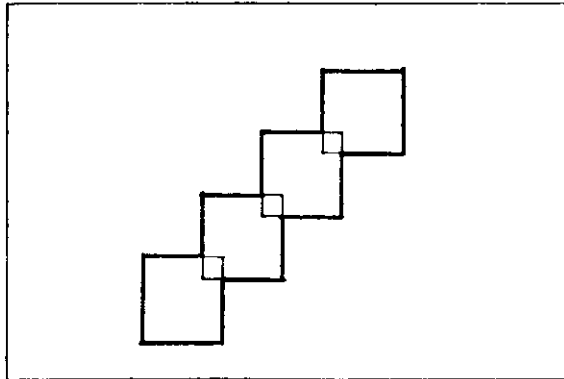
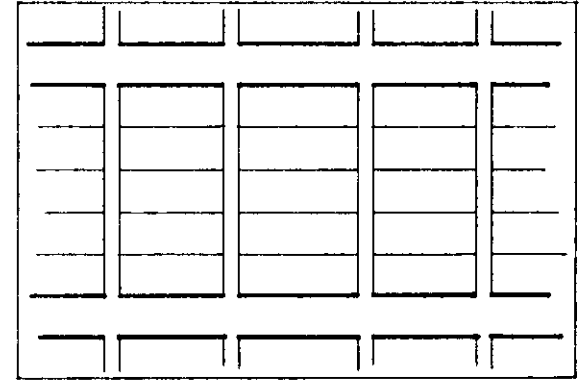
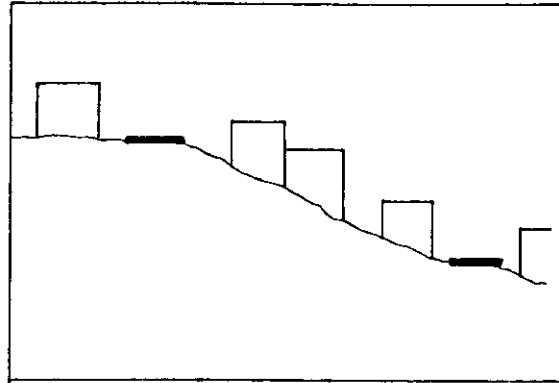
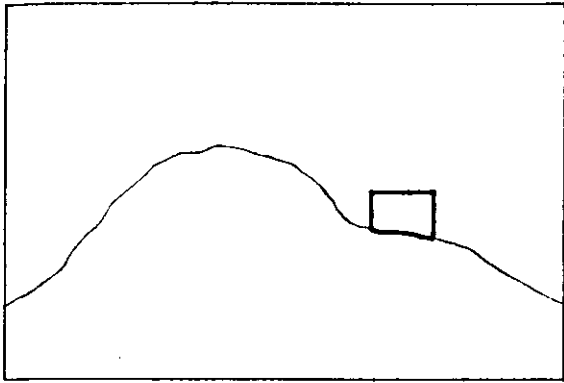

**CONSTRUCTS: THE SITE**

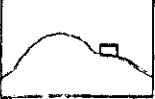

## GENERAL SITE CONSIDERATIONS

It should be noted that the basic issues concerning sensitivity to the site will be only touched upon here. Site sensitivity will be further discussed in the chapter on landscape analysis. It is a law in Jerusalem that buildings cannot be built over a certain number of stories. This especially holds true for the top of a ridge of a hill. In order to remain sensitive to a sloping site, the dwellings should be built upon the military ridge of a hill not on the top of the ridge. This allows for the planting of trees as a backdrop for the development. It also allows for the possibility of having recreational space at this point and the ridge would serve as a windblock protecting the settlement below.

In my viewing of several housing developments around Jerusalem, I noticed that many look as though they are one solid mass. One development looked like a long massive wall running along the side of a hill. The built form itself should be horizontal in look and dwellings scattered along the contours and slope to break away from the solid massive wall effect.

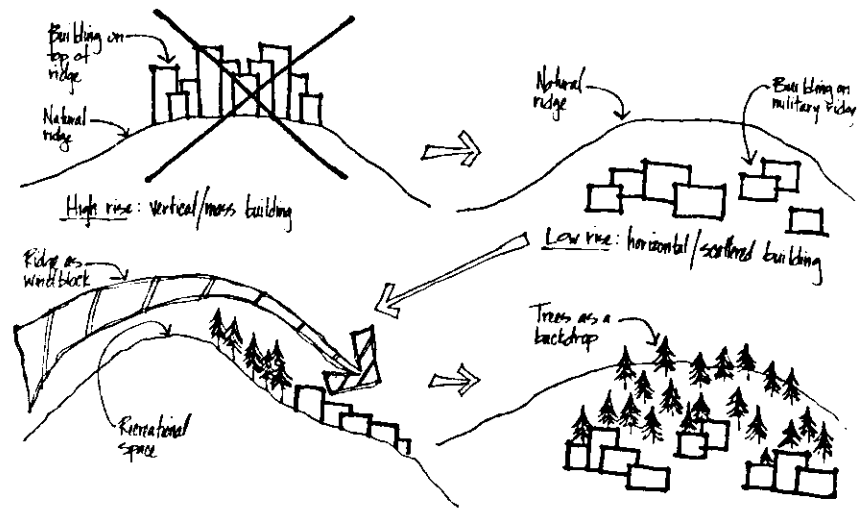

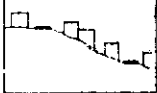

# MAJOR CIRCULATION PATTERNS

Major circulation patterns must be taken into the consideration of a site. In this case a sloping site. The primary network of road systems should follow the contours of the sloping site and be relatively parallel to each other with dwelling clusters inbetween these roads. The secondary pathways would cut against the contours and overlap the primary road system. A sequence of connecting public nodes could be developed along these road/pathway systems in order to enhance the integration of the dwelling clusters. Finally, cut and fill methods might be used to create the stepping down effect of the total development on the site.

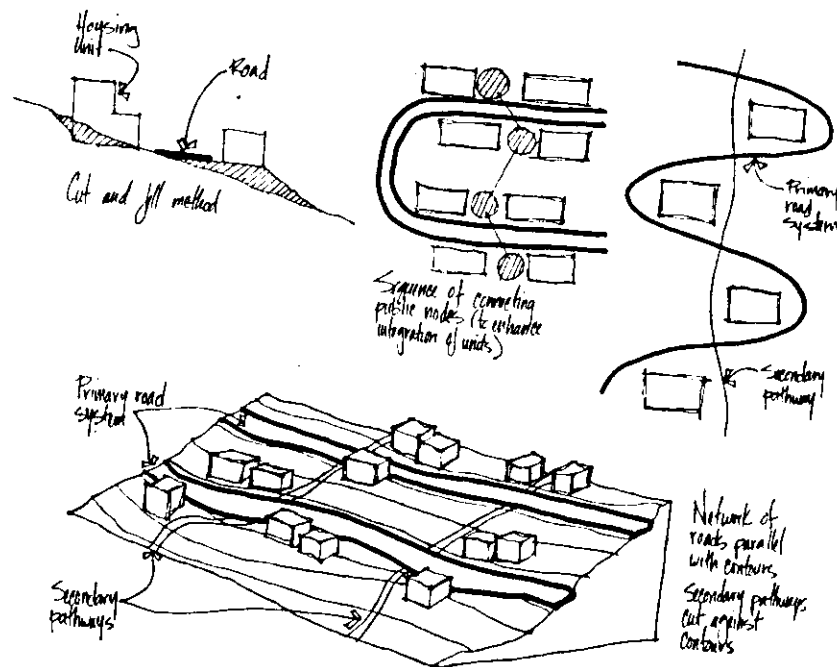



## INTERNAL CIRCULATION PATTERNS

Looking at circulation patterns directly around and within a neighborhood one finds the same thing occurring with the modern development as did with the traditional. There is a main peripheral circulation surrounding individual developments. This circulation caters to the use of automobiles or the like and is basically a circulation path for the public. Once one goes into the development itself, one finds an internal circulation route which is used mainly by the inhabitants of the immediate development. Courtyards of the individual developments are sometimes linked to other courtyards by these internal circulation routes, thus creating an integration and interaction between neighborhoods.

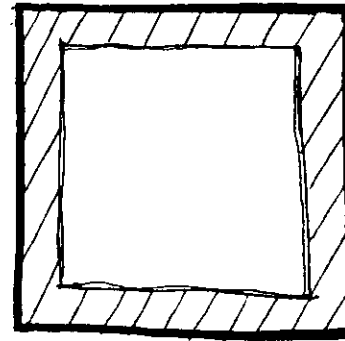

*Peripheral circulation*

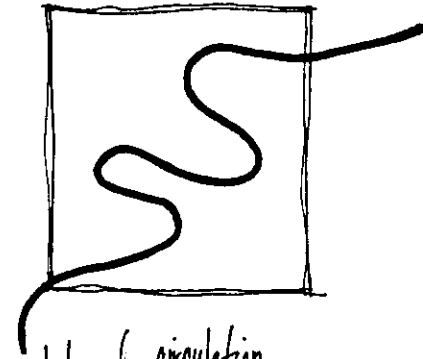

*Internal circulation*

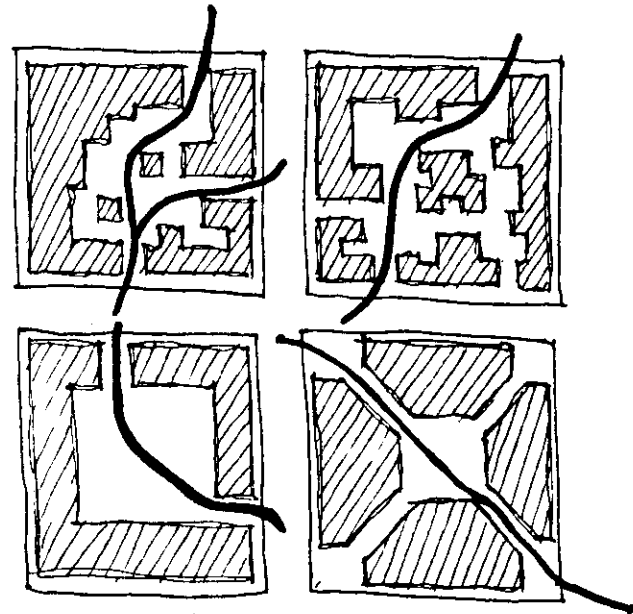

*Diversity of Courtyards*

*-Peripheral and punctuating systems of movement and sequence*

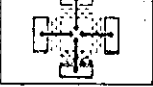

## HIERARCHY OF SPACES

There is a breakdown of exterior spaces that occurs in the traditional housing which I feel should transpire into new developed outdoor spaces. These spaces include the following sequence:

- 1/ Public space: a place for large groups (i.e. families, youth groups, elderly groups, community groups, etc.) to meet. A common place to gather.
- 2/ Semi-public space: this area is more or less of a co-buffer zone between the public and private spaces. It is still a space where everyone is welcome, but is more of a circulation area than anything else.
- 3/ Semi-private space: this area is the other "co-buffer zone" between the public and private spaces. It is an area where the general public is not welcome. It may be designated by a courtyard which is shared by two families or by a single family courtyard attached directly onto the dwelling.
- 4/ Private: this is the last zone in the breakdown of exterior spaces. It is an area that is used only by the immediate occupants. It is the dwelling itself. No one else is welcome unless invited in by a member of the household.

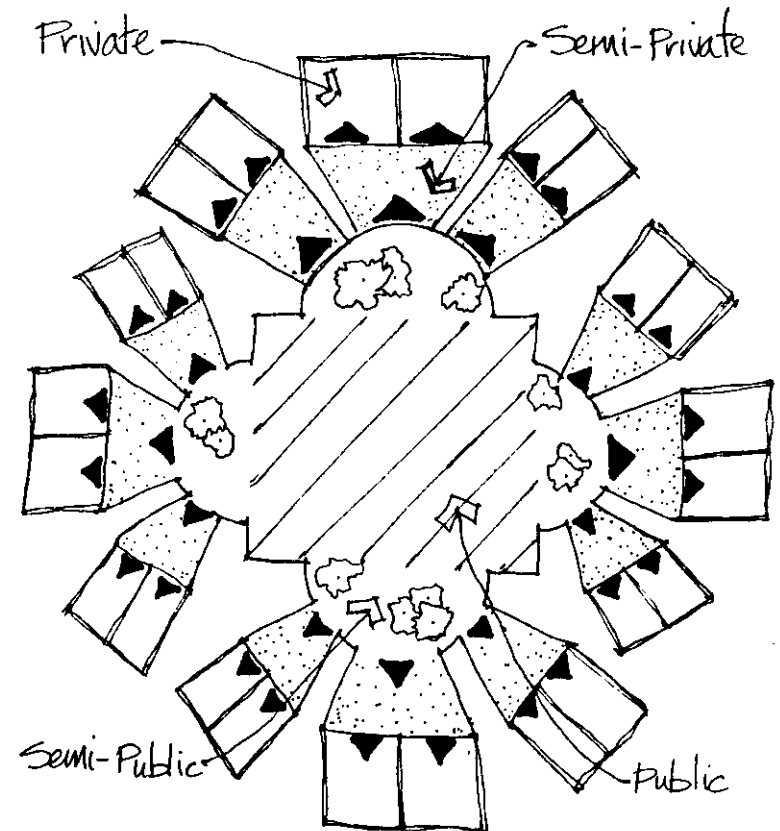

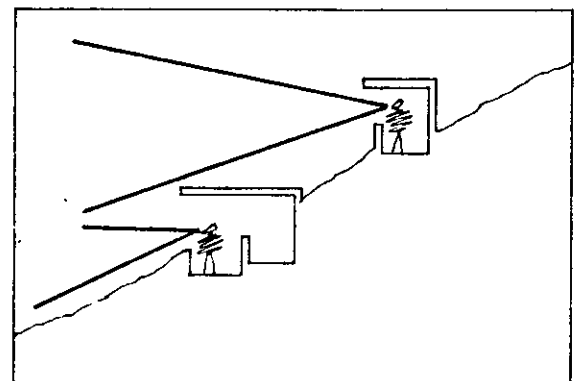
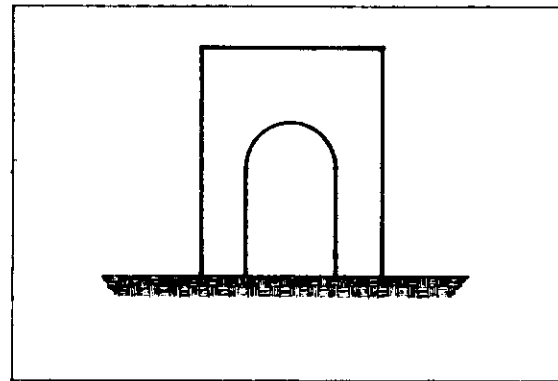
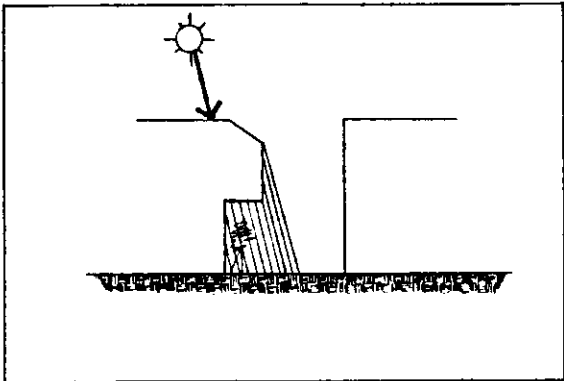
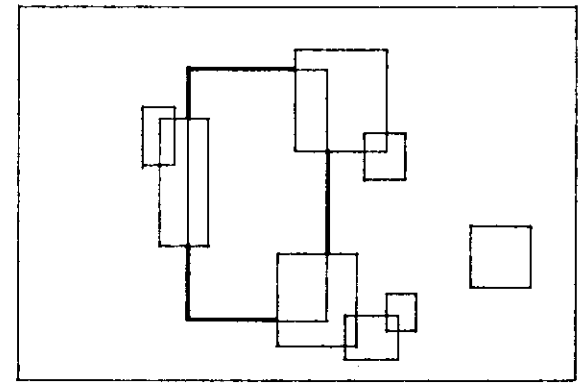
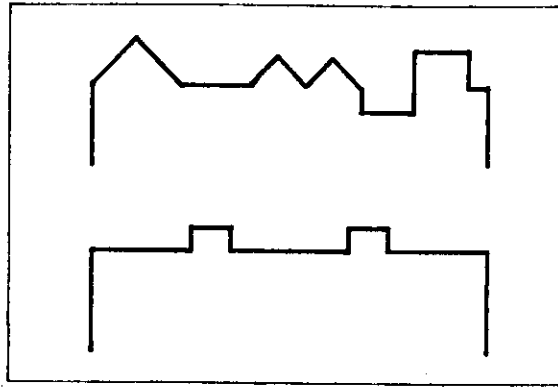
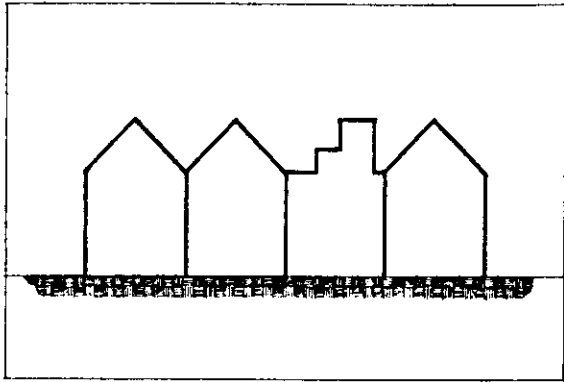

**CONSTRUCTS: THE BUILT FORM**



## INDIVIDUAL IDENTITY

The individual identity of one's dwelling was traditionally created by the building of structures that were different from their neighbors even though they might share a common wall. It was also obtained through the ability to add onto one's dwelling. Modern developments, for economical reasons, have gotten away from the traditional, causing the modern developments to be built as mass forms with no thought to personal identity save for the fact of people selecting different colored curtains.

Through the use of low rise dwellings and the option to add to a dwelling if so desired (with certain limitations), I feel that personal identity can once again be obtained in a relatively economical way.

The silhouette of the built form also adds to the individual identity of a dwelling, and to the overall integrity of a development. Traditionally the skylines of neighborhood developments were diverse. Modern developments seem to ignore this issue. Many have static rooflines broken by an occasional stairwell or elevator shaft projection. New patterns of diversity can be developed by being sensitive to the traditional.

The planes of rooflines can be varied by the actual built form, the use of some rooftop areas for terraces and gardens, and by the planting of trees in areas that would help with the diversity.

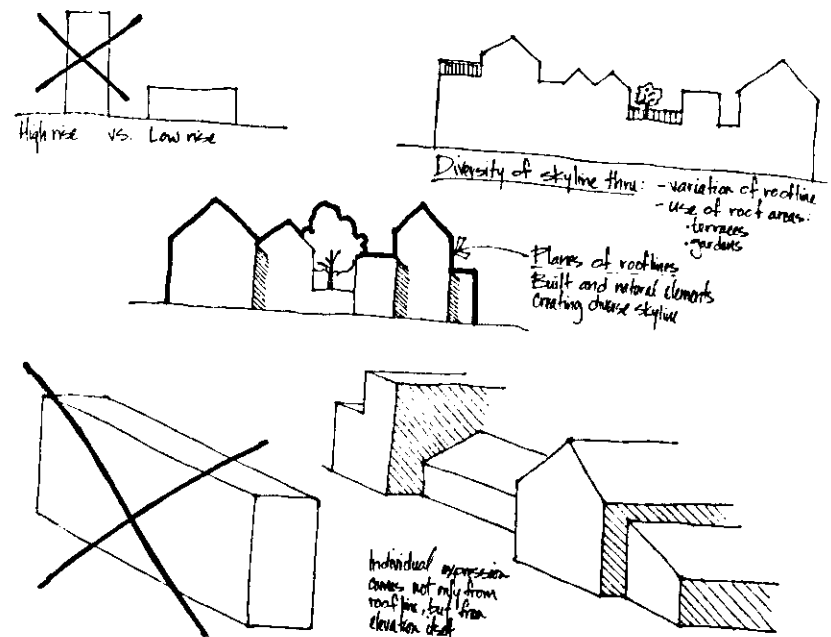

Here lies an ability to increase the square footage of an existing dwelling. It was done with quite a bit of spontaneity in the traditional neighborhoods. No special considerations to context, any material at hand was used for any additions to an existing dwelling, and there was no control over these additions. Modern housing in Jerusalem shows no ability for growth. The dwellings are fixed in size. It is my thought that a happy medium can be used. The ability to grow spontaneously, but the control to enforce the materials to be used and the actual growth areas.

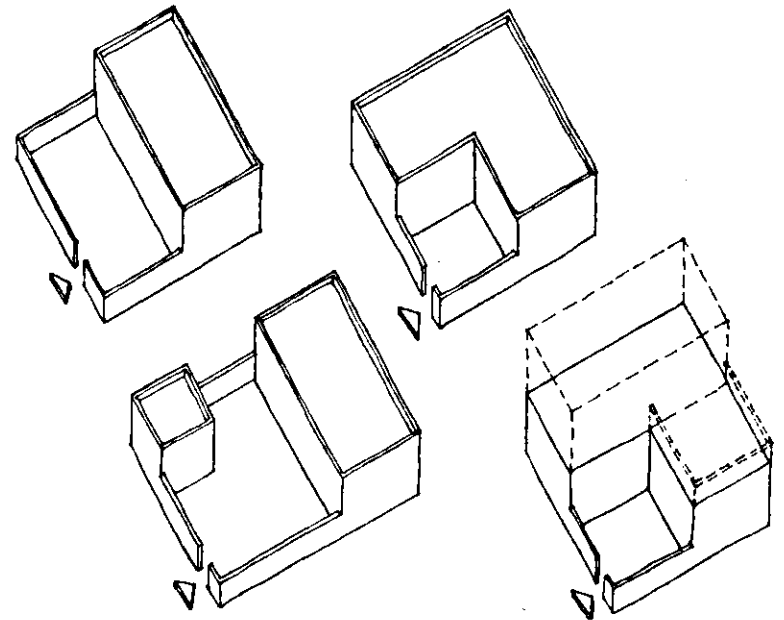
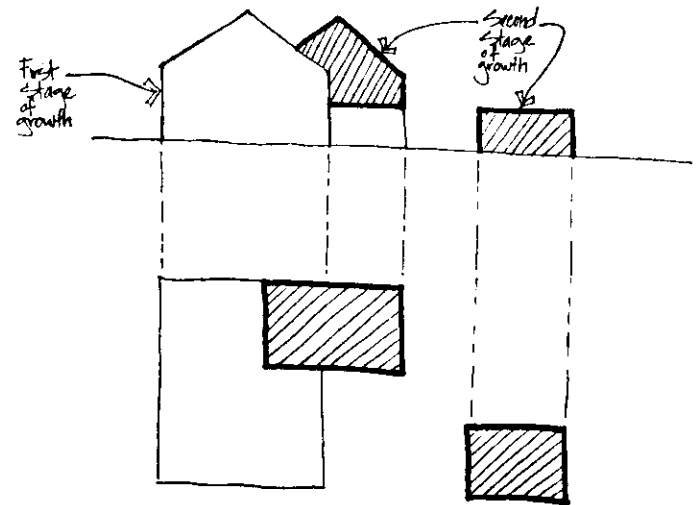



Traditionally and in modern developments the micro-climate has been developed by the use of man-made or natural means. By using what I have dubbed the shadow formula, micro-climate can occur with the actual built form. If the width of a circulation path between two buildings is one half the height of these two surrounding buildings, shading can occur. The micro-climate can be altered by varying the heights of the surrounding buildings.

Another use of the built form is by the application of secondary forms onto the main structure. This can be a balcony for example, or can be an overhang that occurs in the built form itself.

A natural way to create a micro-climate is by the use of vegetation. Existing or strategically planted trees and shrubbery. They may be placed along a walkway for example, to shade the walkway, or planted around an area with a benches and tables so people can sit and rest or play a game of checkers for instance.

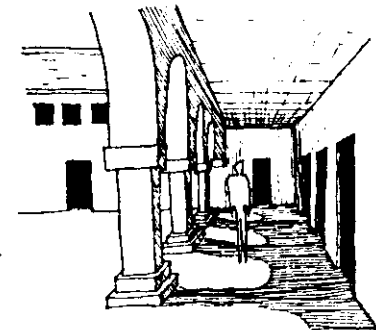
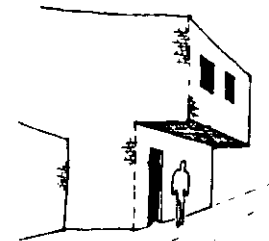
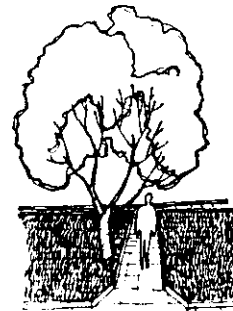
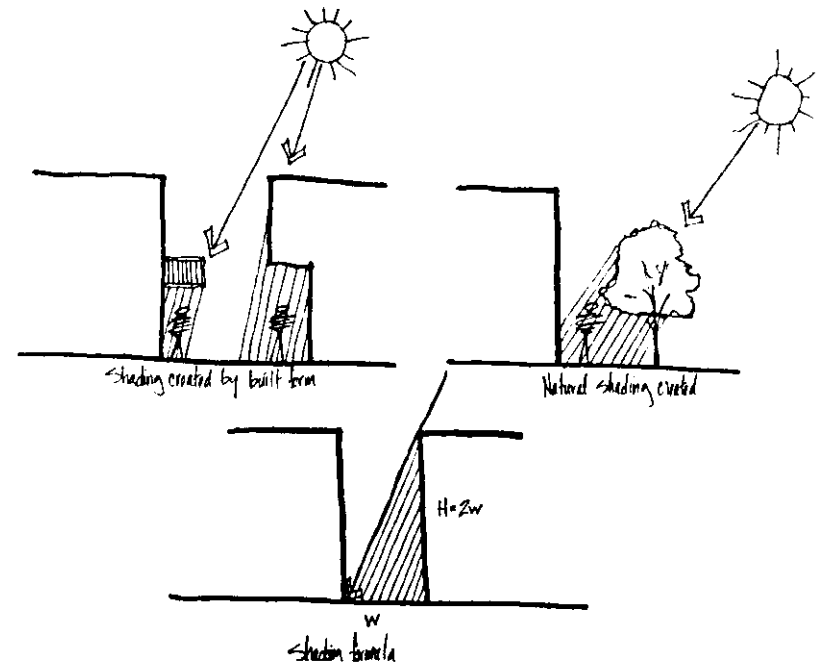



In traditional neighborhoods gateway was formed in various ways:

- 1/ Formed by the actual building form itself.
- 2/ Applied between two buildings.
- 3/ As a gateway along a spacial divider, such as a fence.

In the modern neighborhoods I have visited gateway has been formed as an element one may pass through between two buildings.

As a new pattern the gateway could be used not only as it was in the traditional neighborhoods, but also formed in the plan form and three-dimensional form by the various surrounding built forms. Also as a sequence of gateways not only defining spaces, but separating a sequence of courtyards.

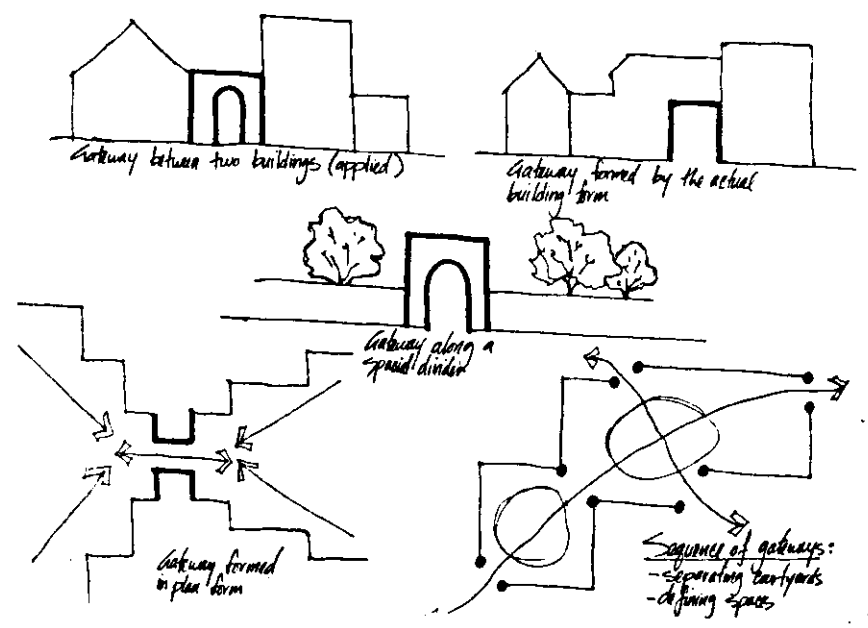

Views are important in the development of neighborhoods. On a sloping site various methods can be used to maintain these wonderful views created by this such type of site. One method is by the stacking of dwellings as not to inhibit views down the slope. While stacking dwellings down a slope one must remember to maintain privacy between dwellings. Inhabitants of an upper unit should be prevented from being able to view into their neighbor's space below. One way to alleviate this is by the use of plantings and a handrail or partial wall with setbacks.

Another method of creating views can be used with either a sloping or more importantly a flat site. Views can be framed with landscaping and by creating gardens that one can view into or down upon.

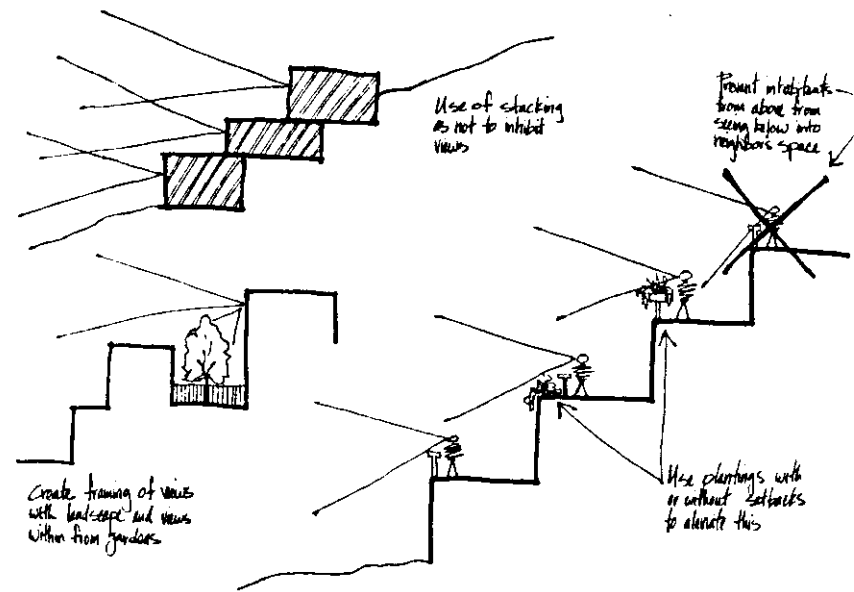

# **SITE STRUCTURE AND CONCEPTS**

---

# THE REGION AND LOCATION

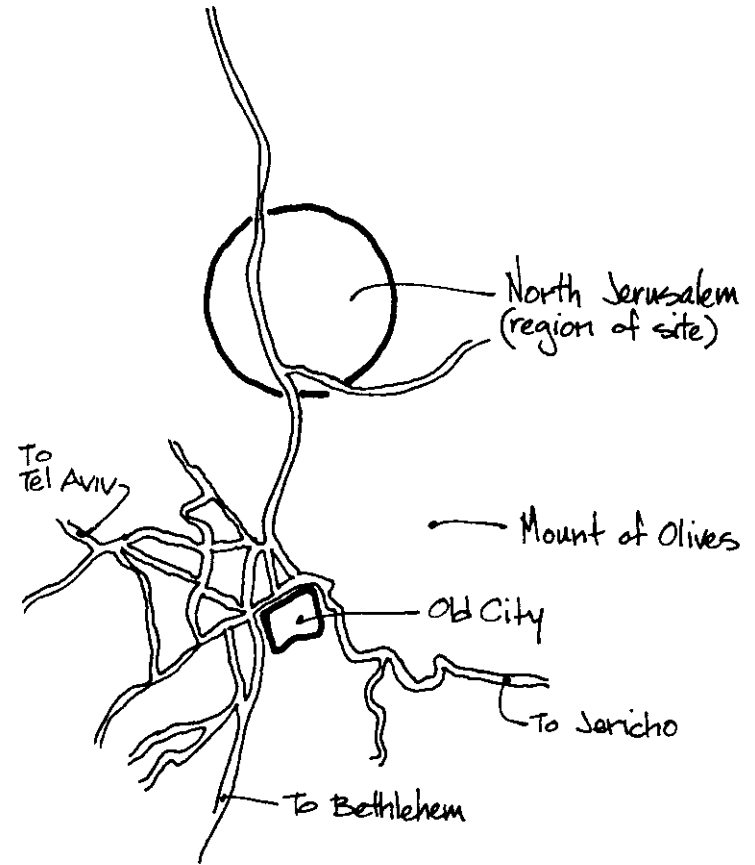
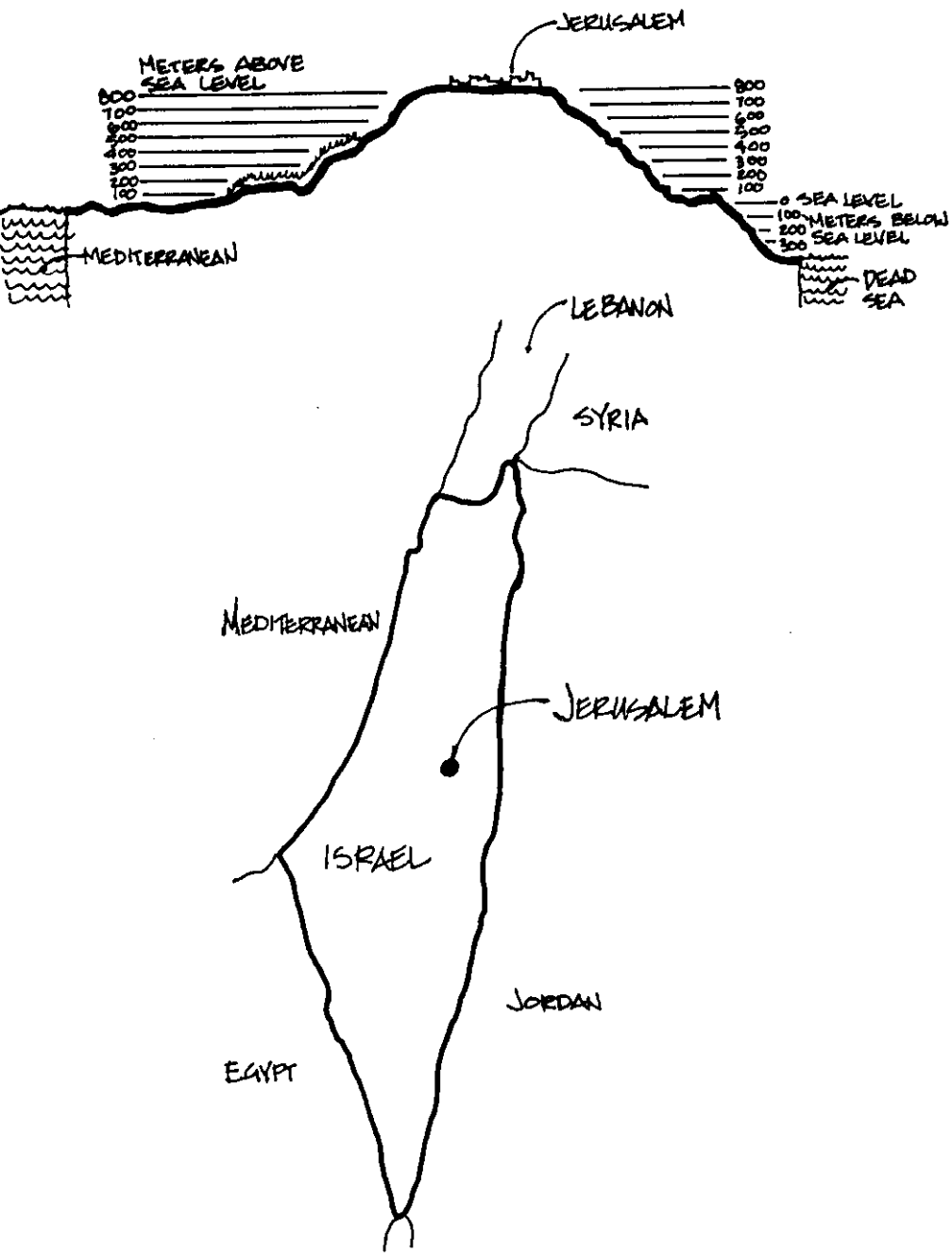

RELATIONSHIP OF SITE  
TO JERUSALEM/OLD CITY

# MAP OF SITE AND SURROUNDING AREA

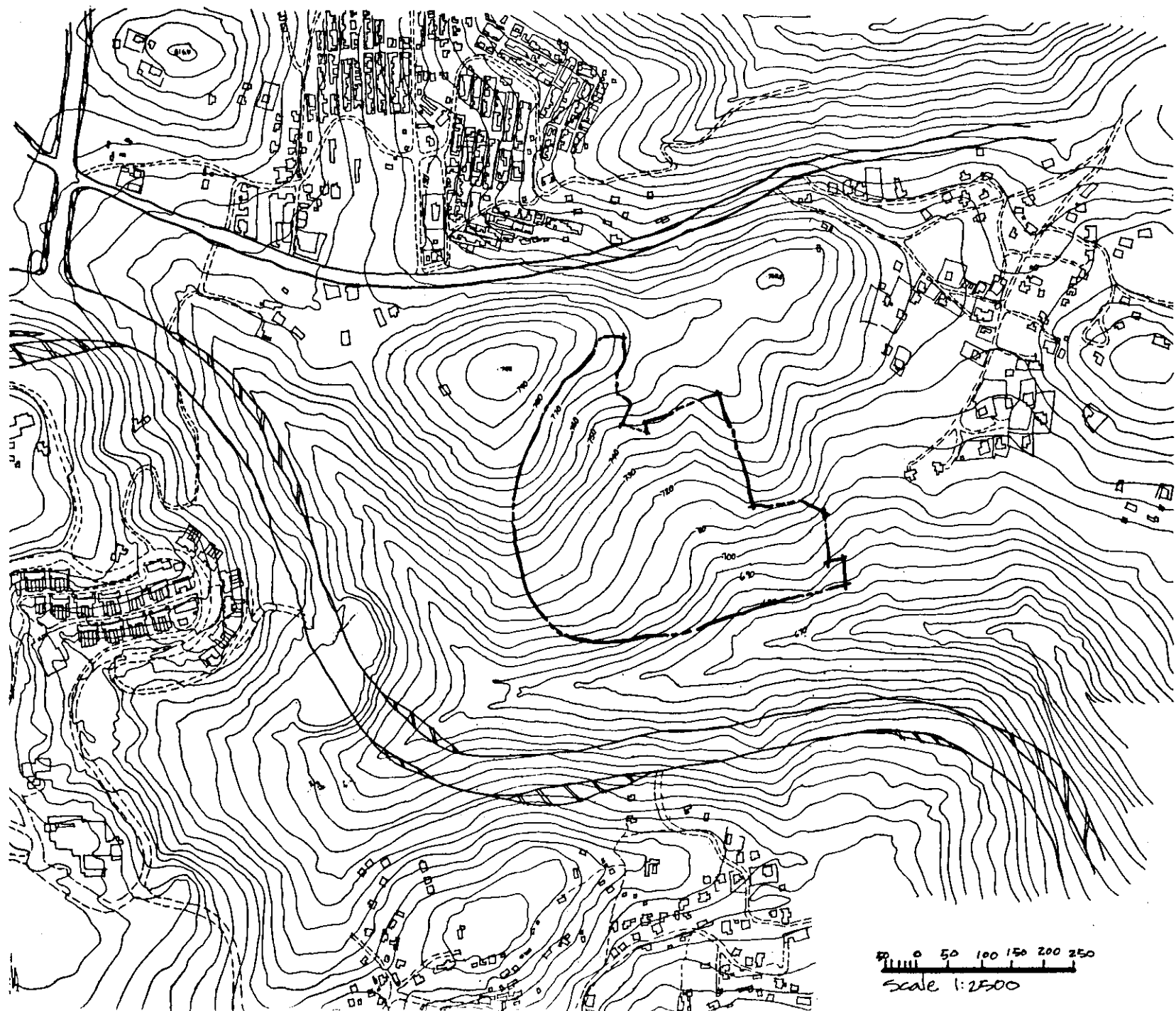



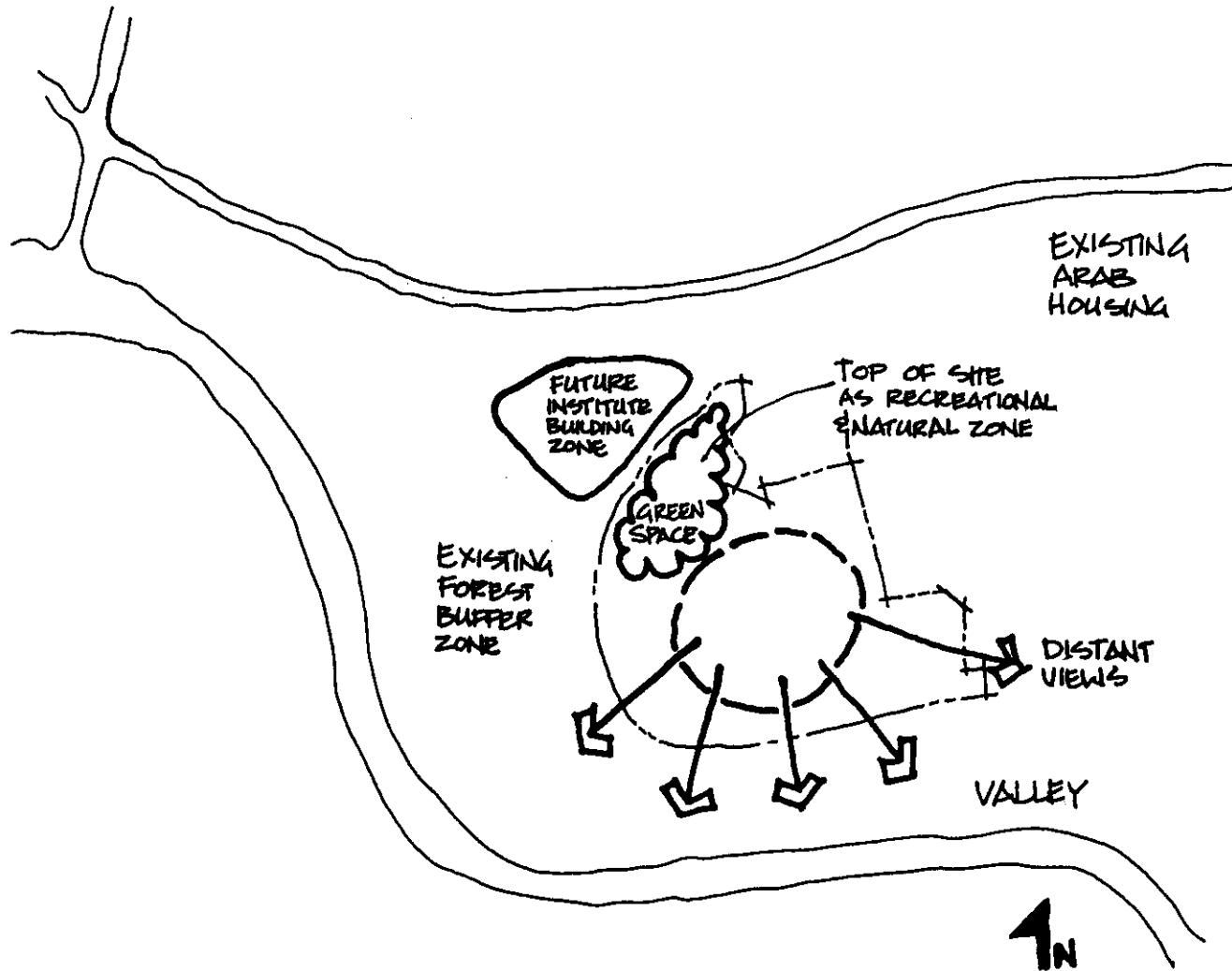

# CONCEPTUAL LAND USE OPTIONS

EXISTING  
INDUSTRIAL  
AREA



# MOVEMENT PATTERNS AND CONNECTIONS

## KEY

-  COMMUNITY FOCAL POINTS & GATEWAYS
-  MAJOR CIRCULATION (MOTOR VEHICLES)
-  SECONDARY CIRCULATION (MAINLY PEDESTRIAN - EMERGENCY/SERVICE)
-  HOUSING DEVELOPMENT AREAS

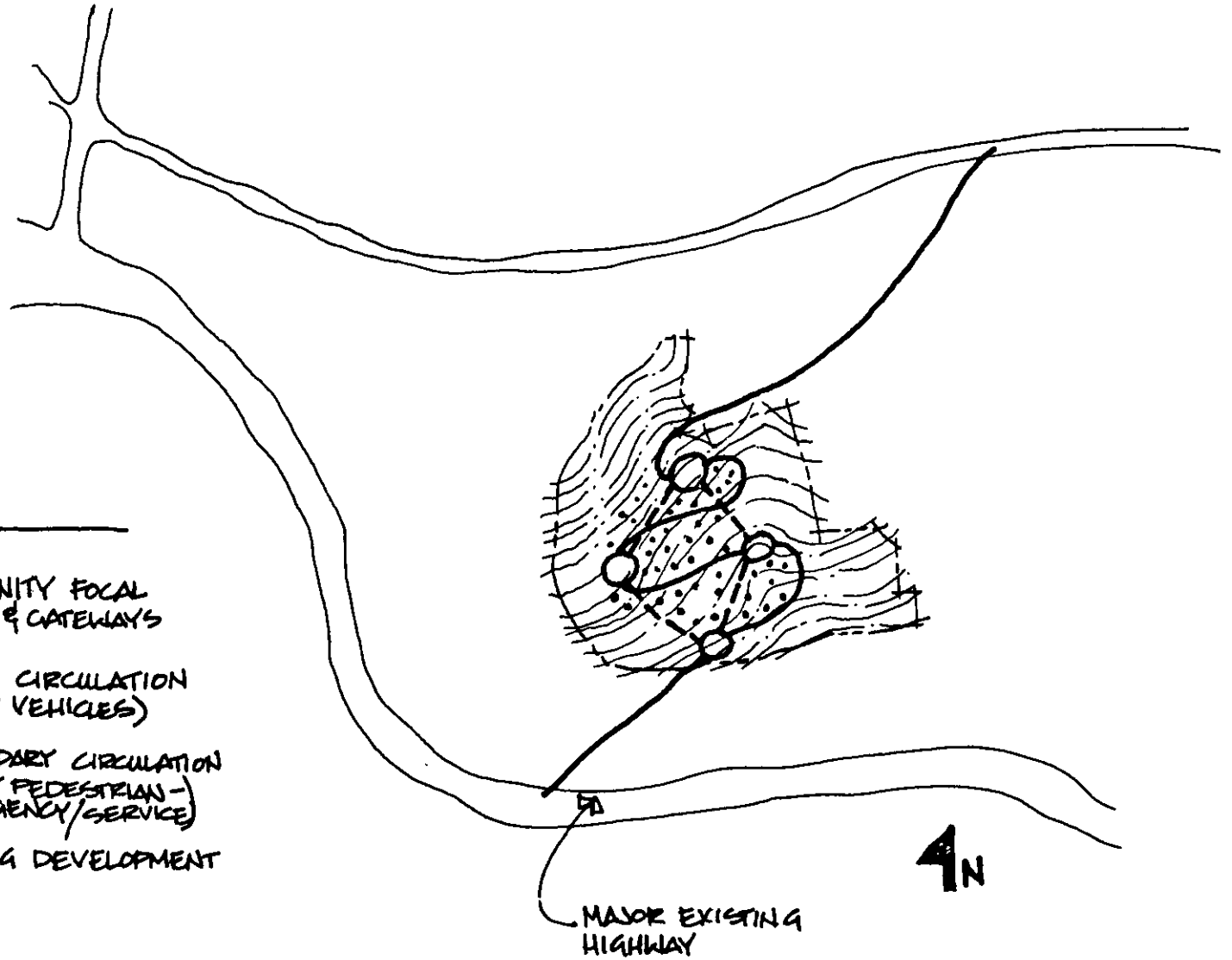

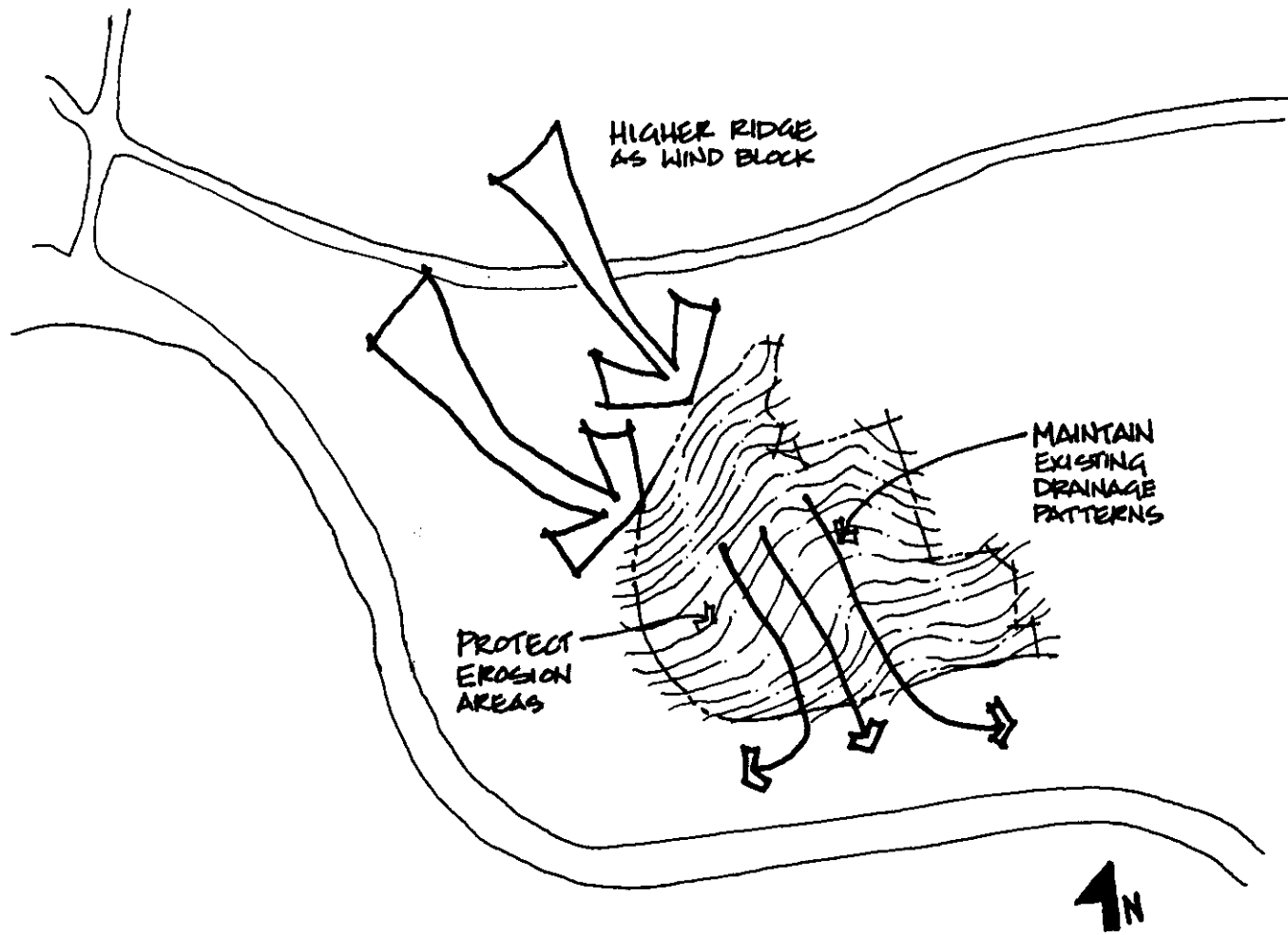

## A LOOK INTO THE PRESERVATION OF JERUSALEM'S SKYLINE

In looking at the traditional Arab housing neighborhoods and other buildings in and around Jerusalem, one can see a definite cohesiveness between landscape and building development. The structures are integrated into the landscape. They are scattered and speckled along the terrain and contours of the landscape by using terraces, etc. They are randomly dispersed on the contours of the land which is quite hilly with the ability for growth if the need arises. They are low to the ground and have a horizontal quality. They are "one" with the landscape.

On the otherhand, modern building practice has lended itself to be leaning against this. It stresses verticality rather than horizontality. The structures are taller than their surrounding neighbors. A few major hotels in Jerusalem can be cited as examples of this. They were meant to be landmarks and were obviously more economical to the site. The taller and more prominent the better. Instead of being an integral part of the landscape the hotels stick out like sore thumbs. Legislature put an end to this practice and now limits the number of stories one can build. One example of this is the Hyatt Hotel on the Mount Scopus ridge where a vertical scheme was originally developed, was defeated, and a more sensitive design was finalized. The first design would have made the hotel dwarf the Old City. The final design follows the natural topography. It spreads out over most of the terrain, but doesn't exceed more than four or five graded floors above

the ridge of Mt. Scopus. As opposed to the first plan which was twenty-two stories high.

Modern housing in Jersalem in recent years has fallen under the same norm as the hotels to a certain extent. Housing developments have become large massive walls of stone along the landscape.

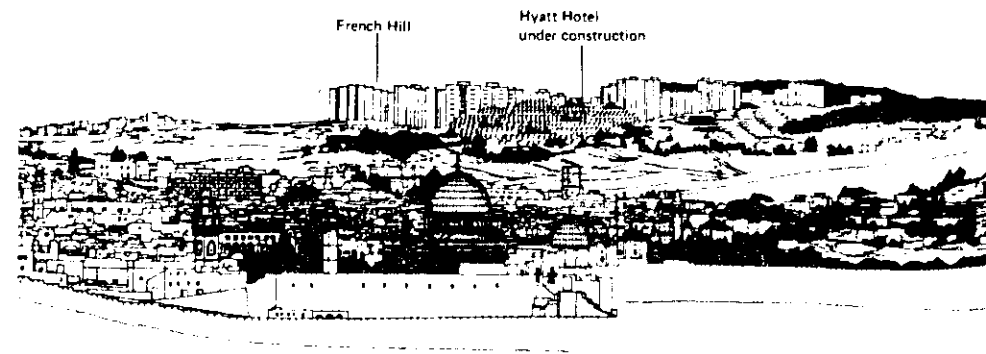
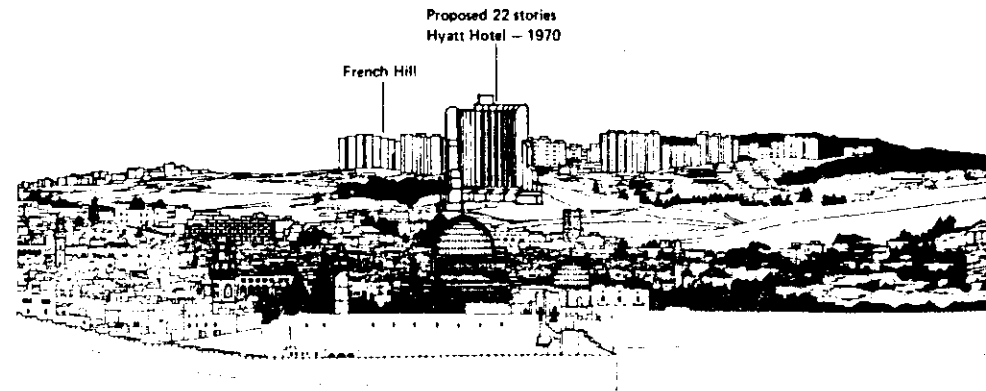

(Kroyanker, p.128)

**HOUSING PRINCIPLES AND CRITERIA AS RELATED  
TO TRADITIONAL/CONTEMPORARY ASPECTS**

---

# SUMMARY OF CRITERIA FROM TRADITIONAL ANALYSIS





## SUMMARY OF CRITERIA FROM TRADITIONAL ANALYSIS

The following summarized criteria from the traditional neighborhoods, I feel, should be maintained as patterns for planning and building in the contemporary setting. I feel that these criteria, along with the other constructs would benefit the integrity of a housing development.

### SCHEME--A

This scheme shows what would make up a portion of a larger development. The dwelling units are clustered into smaller groups with adjoining courtyards. The local focal point is situated amongst a cluster of dwellings. This focal point could be a synagogue, kindergarten, etc. Something that would draw the use of others from immediately neighboring clusters of dwelling units. The district focal point would contain facilities such that it would draw the use of people from the overall development, not only the adjacent unit clusters.

### KEY

	vehicular circulation
	pedestrian circulation
	local focal point
	district focal point
	micro-climate

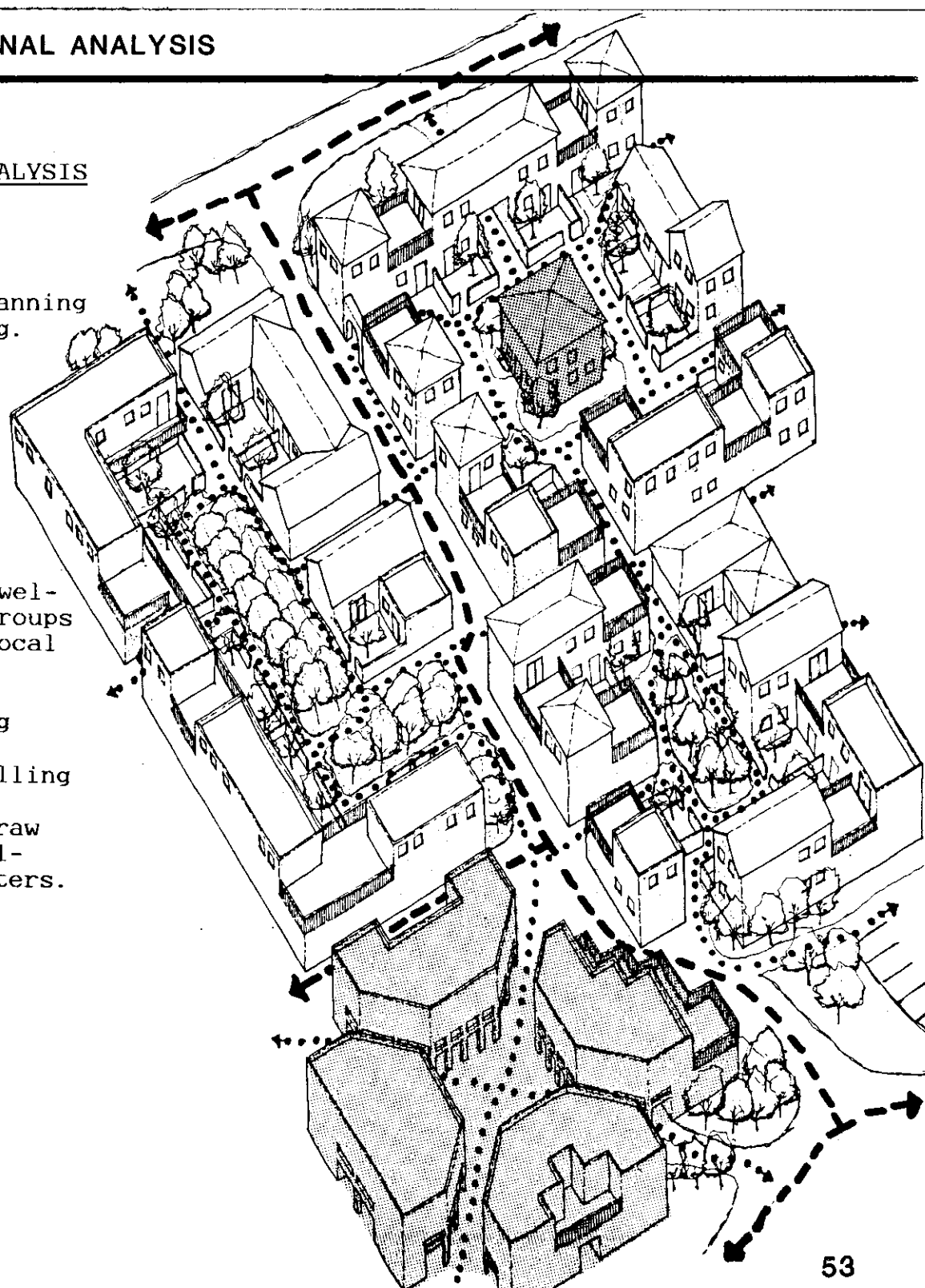

KEY

- vehicular circulation  
..... pedestrian circulation  
▨ local focal point  
▩ district focal point  
□ micro-climate

SCHEME--B

This scheme is similar to scheme -A with the exception that its local focal point is situated in a common area amongst three separate clusters of dwellings with a common open space also. All of the units also have flat roofs instead of the combined pitched and flat roofs of scheme -A. Both schemes show the diversity of the dwellings units through possible growth and plan arrangement. A hierarchy of spaces as well as gateway and inward views also occurs in both schemes.

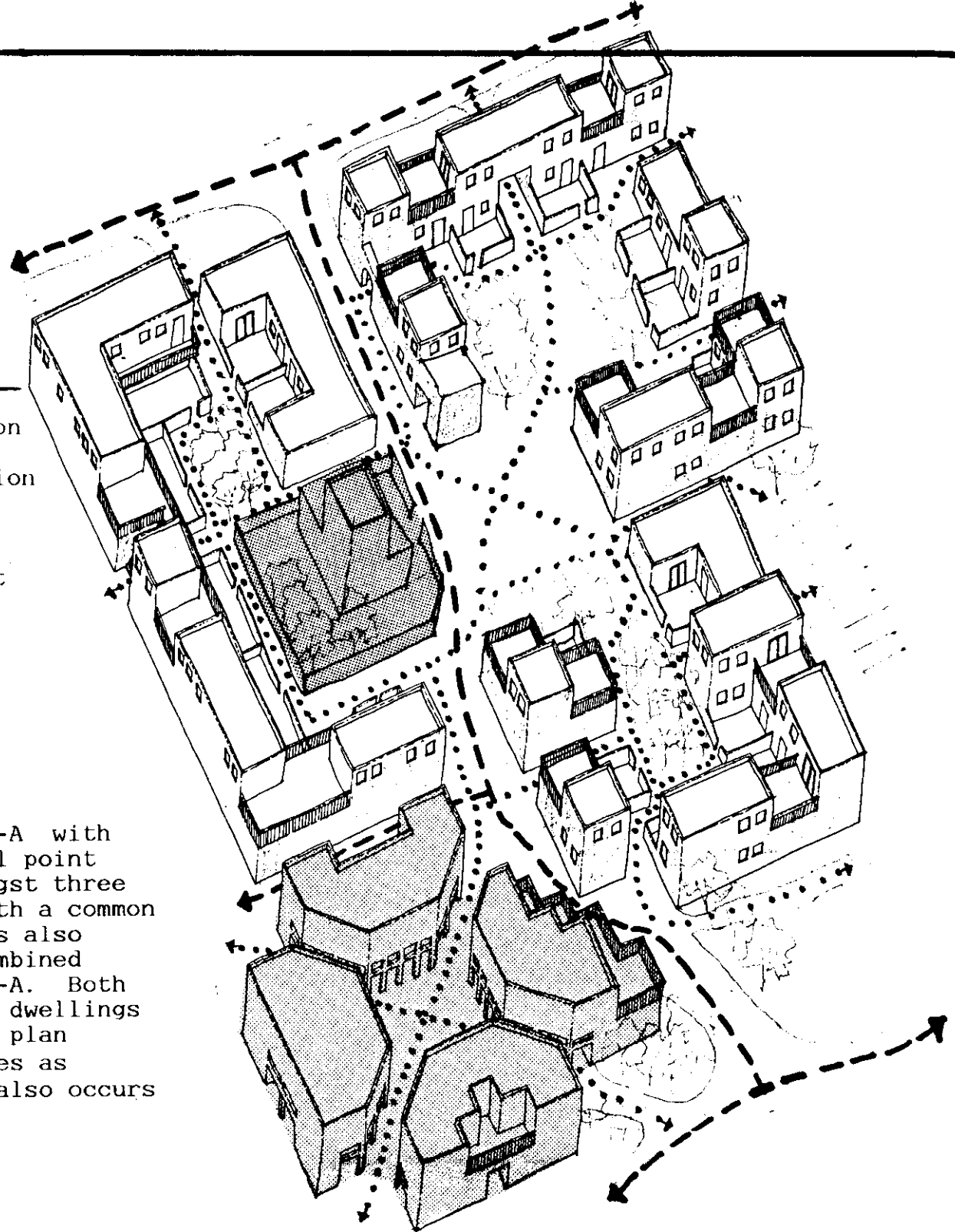

## TRADITIONAL TYPE PLAN ANALYSIS

By looking at the plan of a traditional dwelling (roughly 45-60 sq.m) one can break down a typical layout that was commonly used at that time.

Located off the central courtyard was the private courtyard of the individual dwelling. In this courtyard a latrine was located usually at the entrance of the courtyard. Trees were also located in the private court for shading purposes. One would then enter into the hierarchy of the dwelling itself. The kitchen, the most public room, was typically located in the courtyard but directly adjacent to the main dwelling. Next was the semi-private "hall," probably used for receiving guests and dining.

The room adjacent to the hall was the "interior room." This was more than likely the most private room in the dwelling. A room allowed only for family members. It was probably the general sleeping quarters. These simple dwellings shared a common wall usually on both sides.

When a family got larger and more space was needed, a second story was added on with a balcony usually on the wall facing the outer edge of the neighborhood. As the next stage of growth occurred, balconies were more than likely enclosed, the kitchen on the lower level might be enlarged, and an additional house might be built around and over the existing latrine. It must be added that eventually an indoor bathroom and plumbing was installed as technology progressed.

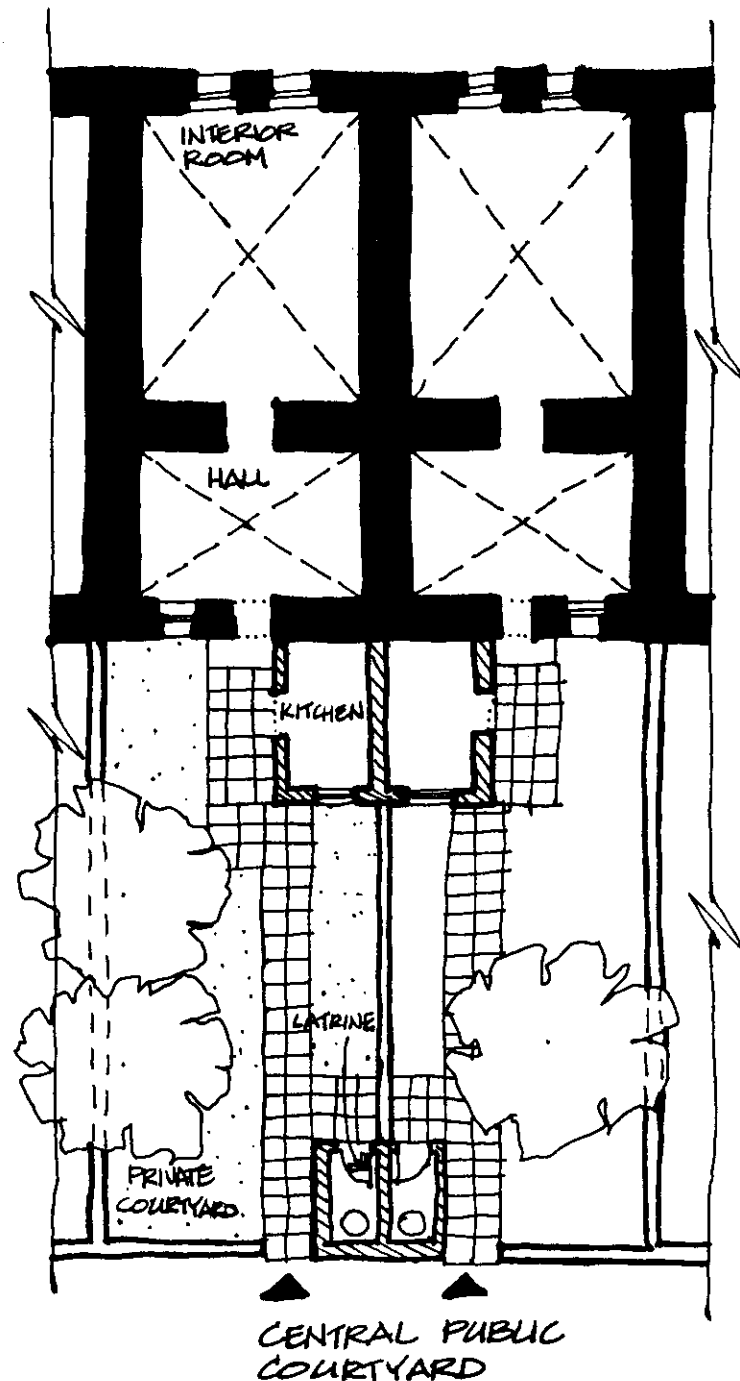

While walking around these neighborhoods, I noticed that while maybe originally many of these dwellings were of the same plan and style; with their various additions came individuality and a playful spontaneity. These additions are noticeable and the materials which make them up don't necessarily follow the rules of construction set down by the Jerusalem planners. I observed much corrugated metal used for the additions.

#### CONTEMPORARY TYPE PLAN ANALYSIS

For the contemporary type plan analysis I chose Rochamimoff's Ramot neighborhood as a common type plan. Typically in Jerusalem one finds single level apartments. Because of the climate, cross-ventilation becomes quite important. The type plan (roughly 45-90 sq.m) consists of entering at the most public point in the dwelling, the kitchen or dining area. Directly adjacent to the kitchen/dining area is the living area. Off of the more public areas are the more private areas of the dwelling, the individual bedrooms. I observed anywhere from one up to four per dwelling.

At Ramot there exists a feature that doesn't occur at many of the other satellite communities. Because Ramot is a low rise development, it is the perfect opportunity to introduce private terraces (10sq.m) off each dwelling. The terraces were surrounded by the living room and one or two bedrooms with direct access from each. These terraces also

had a desirable feature of a trellis shading device overhead. It let light through but also blocked much of the hot sun to provide for a comfortable sitting area.

The one feature this complex and all of the other satellite communities I observed didn't have is the ability for growth to occur. Ramot, on the whole though, was closest in trying to integrate some of the successful traditional patterns I had observed in my breakdown of the traditional neighborhoods. True; times, needs, and functions are constantly changing, but there are some aspects in planning that should not be lost as they are in many modern satellite communities.

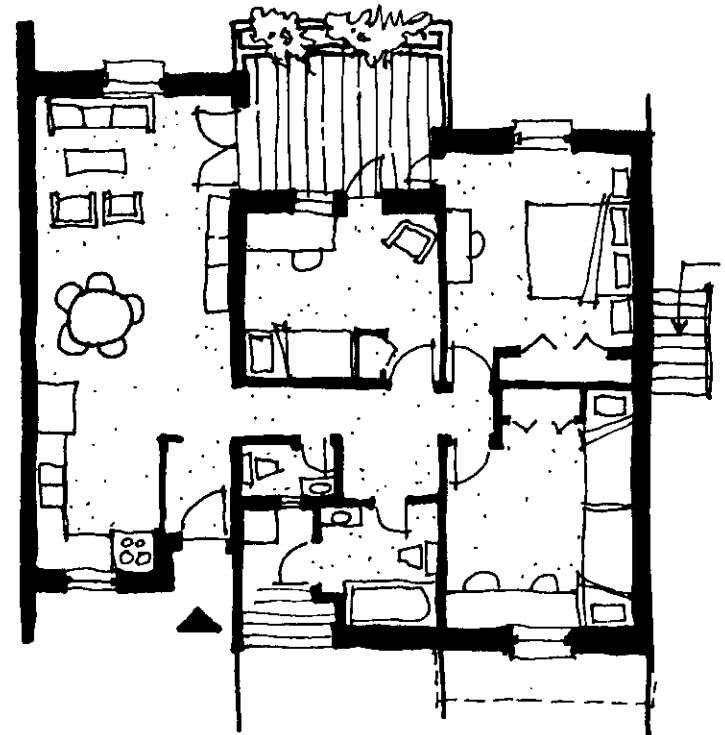

## CLIMATE

Jerusalem's climate can be technically described as a tropical and subtropical desert climate. This means that Jerusalem and all of Israel has hot summers and mild winters. Some areas of Israel are lush with foliage. The foliage in areas surrounding Jerusalem becomes more sparse, turning into brush and exposed soil with little or no trees. Such is the area of my site. The climate will have some impact on the orientation of the dwelling on the site and other factors such as shading and wind flow as a natural cooling device.

## MATERIALS

Luckily, the use of Jerusalem stone has endured many years as a primary building material. Traditionally it was used out of necessity. In modern times, even with the ability to face buildings with a wide range of materials, it is a law in Jerusalem that a building must have a certain percentage of Jerusalem stone as its fascia. Concrete makes up the remaining percentage. As far as I could tell, the structure of the majority of housing developments I observed were of reinforced concrete construction. A combination of poured and block. The stone is no longer used in the structure of a dwelling, but is now more or less used only as a facing material.

Various textures of the local stone can be utilized. (See Preface to Thesis, History

of the Traditional Jewish Neighborhood)  
It is lovely to see how the lighting around Jerusalem affects the stone at different times of the day. When the sun is at its brightest, the stone on the buildings are affected by the intense light and look almost white. As the sun is setting and different colors play on the horizon, the stone-faced buildings literally glow and change colors as the sky does.

The city planners knew what they were doing when they put the strict restrictions of building practices in Jerusalem. To walk up the Mount of Olives and look back on the city below, one views a city that is integrated by its wonderful use of the local stone, thus making it a truly beautiful city to behold.

## THE SITE AND SITE CONCEPTS

When planning a development on a site one must consider several issues. Those being orientation of the units, topography of the site, along with the actual site layout.

In Jerusalem the best orientation of the main living areas of a dwelling is a south to south-west orientation. This is desirable to provide the maximum insulation as possible for the walls and rooms from the direct rays of the sun for about six or seven months of the year. This orientation also has the advantage of the prevailing westerly winds which cool the outside walls and can provide a cross breeze through the

dwelling.

Topography is an important factor in determining the placement of dwelling units on a site. If a sloping site is being utilized, views

Topography is an important factor in determining the placement of dwelling units on a site. If a sloping site is being utilized, views play an important part. Taking advantage of the slope can provide for the majority of dwelling units having an optimum view down the slope, thus increasing the visual plane and giving the feeling of being uncrowded. Unit layout is mainly a linear layout, parallel to the contours and stepping down the slope. Linear courtyards are then developed along the units. Primary road layouts for a sloped site usually run parallel to the contours of the site with the secondary roads and pathways running perpendicular to the contours. Natural site drainage also occurs with a sloping site.

If a flat site is being developed, inward views become important. Unit clustering around a main courtyard can be used as well as a linear development. In a cluster development, since the views are mainly inward, unit arrangement and landscaping become important. Primary roads usually occur on the perimeter of the development with secondary roads and pathways being introduced within the cluster of units themselves.

#### IMAGE AS RELATED TO COMMUNITY IDENTIFICATION

Dwelling developments should evoke a certain feeling of community identity. The development should work as a whole to promote interaction between inhabitants, by creating an atmosphere where children to the elderly can both partake in and enjoy together. Community centers and various courtyard layouts can help to provide this. Individual units should maintain personal identity and yet still relate to the overall community. Support businesses, schools, and religious centers can also help to integrate a community and identify it.

#### IMAGE AS RELATED TO CULTURES AND TRADITIONS

Cultures and their traditions play an important role to the image of a housing development. By studying the sociological aspects of a society, one can start to understand the wants and needs of a group of people. A culture's way of life, their economic needs, the technology of a culture, the building materials available, the climate and surrounding landforms all relate to how the planning of their dwellings, individual and group, should be handled.

By transforming and evolving the traditional identity and values of a culture into new building patterns one develops housing that is rooted in tradition and thus forth maintains a level of identity and integrity a culture might lose if these things are ignored completely.

## INTERVIEW WITH ARIE ROHAMIMOFF

- K. What do you think of tiled roofs?
- A. Tiled roofs are awkward in the desert. They don't suit the desert.
- K. What roof shapes are the best for the area of my site?
- A. Flat and domed roofs are the best. They are traditional on the other side of the ridge where your site is located.
- K. What about views? (Especially on a sloping site)
- A. There are different architectural faces and views. There is the internal view and the external view.
- K. Do you have any personal guidelines for the process of growth?
- A. Yes. Maximize the growth potential and deduct from it.
- K. What are a few things I should remember in the development of courtyard typology of architecture?
- A. A few things to remember are that traditionally there were separate groups to each courtyard development. This doesn't exist in modern developments. An option might be to locate a synagogue or kindergarten between development cells in order to draw the two separate cells together.
- K. I know that stone is a required material. It doesn't seem to be used as much for the actual structure of dwellings, but more as a facing material, and is cut in various interesting patterns and textures and is combined with other materials such as concrete. What are your thoughts on the technical side of the development of dwellings using materials as an example?
- A. The technological side of it is an interesting thing. I feel that the stone should be used in an appropriate way in view of the technology. I feel that when working with the Jerusalem stone that how one punctures walls is quite important.
- K. How do you solve the problem of parking?
- A. Parking is a problem. I suggest that you locate various parking groups within the texture. Different walking patterns can be created.
- K. Do you have any more thoughts you would like to add to this conversation?
- A. Yes, a few thoughts. I feel that you should strive for multiple architectural designs. I should state it in this way. To have one architecture with the ability for spontaneity.

**PROGRAM**

---

## DENSITY/SITE CONTENT

Density is an important issue when developing a site for residential use. By looking at past housing projects, one can get a better understanding for what range of density would be most beneficial for a residential community in Jerusalem.

The traditional quarter of Mazkeret Moshe (1882), mentioned earlier in these writings, can be cited as one example of typical density for a traditional residential project. Its total area is roughly 9100m<sup>2</sup> which translates into roughly 2.25 acres. Of the 9100m<sup>2</sup>, approximately 2000m<sup>2</sup> was used as open public space and approximately 2850m<sup>2</sup> was used as private courtyards. There were approximately twenty-five dwelling units making up this residential community. Some of these units had been expanded to become two to three stories high each depending on the growth needs of the families that occupy them.

Density for a typical modern example is cited as follows. One of the dwelling groupings of the Gilo neighborhood in southern Jerusalem consists of approximately seventy dwelling units. The overall area the dwelling units are situated on is approximately 4500m<sup>2</sup> or roughly 1.11 acres. The dwellings are five stories high and are massed together around a centralized inner court. There is no room for expansion with these units.

One must remember that the spacial needs back in the days of the Mazkeret Moshe quarter were different from those of the Gilo development today. There was an almost unlimited area of land on which to build. Although groups of people would build their

homes directly next to each other for security reasons, the population was such that each dwelling could stand alone as its own entity. (Growth, for instance.) Nowadays the population has grown considerably. Land to build on is growing scarce, so the most is made of this valuable commodity. Residential communities have been forced to build up rather than out in many cases. Both the traditional and contemporary neighborhoods were fairly independent with their own synagogues, schools, open activity areas, etc.

In my studies, I wish to return to a more intimate level of density. While still trying to maintain a realistic density factor; to try and introduce density options. One way to strive for this would be to introduce more than one dwelling unit grouping possibility. Medium high rise units, low rise clustered units, and some individual units, with some of the said units having the ability for growth and change, thus retaining the spontaneity of the traditional neighborhoods.

I feel that with the site I have chosen, this could be accomplished by maintaining a maximum of five hundred units for five hundred families. The units themselves would consist of varying two, three, and four bedroom units with growth factors figured into certain units. Support facilities such as synagogues, schools, day care, and outdoor activity areas would be included. Urban centers, which would act as focal points (district and local), would contain these various facilities

as well as other facilities such as small groceries, pharmacies, etc. This would enable the housing development as a whole to be somewhat independent.

### CONTENT OF THE SITE

The development of the actual community of dwellings could start at three hundred units with the ability to have a maximum of five hundred units. This number seems to work out to a comfortable density for the site; in keeping with an efficient development of the site, yet not overly crowded.

I feel that by introducing no more than three major district focal points, this would be in keeping with the density of the overall development. This would enable the dwellings to be initially grouped into three groups of one hundred units. Each group of one hundred units per focal point. These district focal points would serve the whole community of three hundred.

The first focal point as one would approach the entire development, from the valley, could be the main urban center of the whole community. It would serve as the main gateway of the community as a whole. As one travels up the site the second and centralized district focal point could be the schools and day care centers for the children. By locating these facilities in the center of the development, they would be most accessible to all of the surrounding families and a sense of security would be developed being that the schools

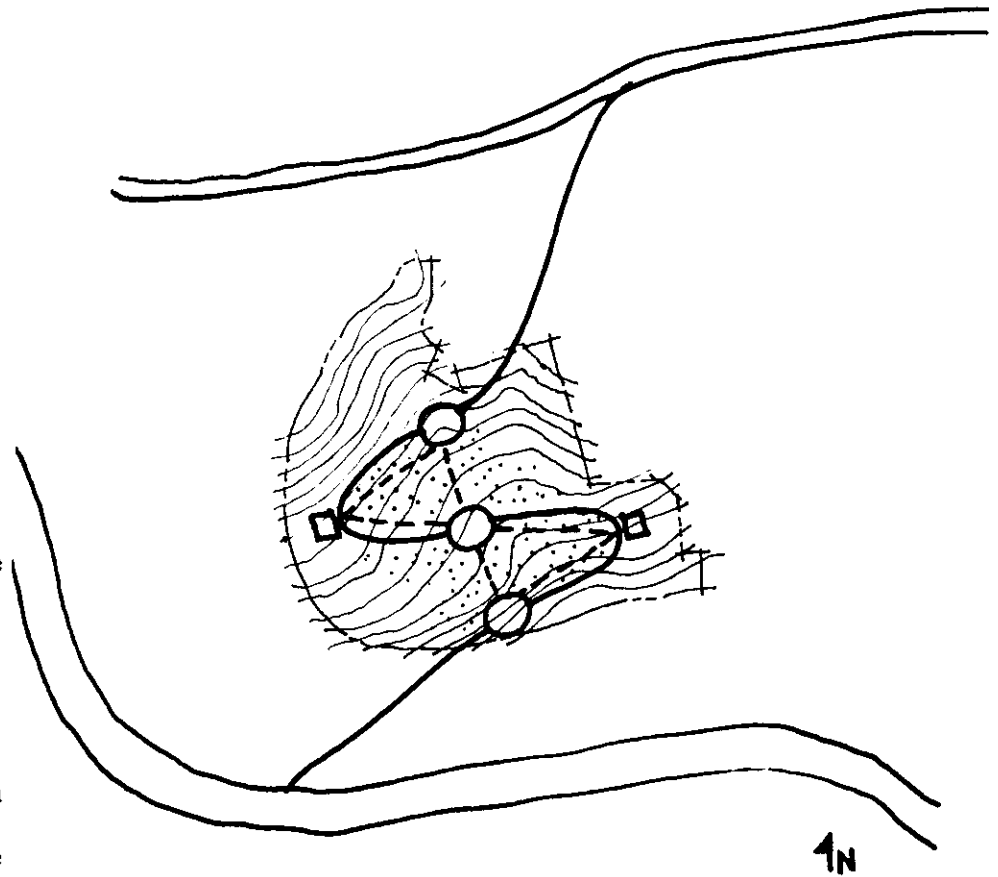

### KEY

- COMMUNITY FOCAL POINTS
- MAJOR CIRCULATION (MOTOR VEHICLES)
- - - SECONDARY CIRCULATION (PEDESTRIAN/SERVICE)
- PUBLIC RECREATIONAL AREAS
- ⋯ HOUSING DEVELOPMENT AREAS

and day care facilities would be at the heart of the community with the dwelling unit developments serving a protective "walls" around these areas. The third district focal point could serve as another urban center and gateway from the back of the development. It would be located just below the upper most point of the development and could be the religious center of the whole development.

There would be local focal points located amongst the development of each one hundred units. These might be green spaces for more localized activities that might occur within each set of one hundred units on a more intimate scale. (Eventually breaking down into private outdoor courtyards for each unit, thus creating a hierarchy of spaces for the overall development.) The outer curves of the main vehicular circulation route could be utilized as public recreational areas. One might be a large playing field; another a park. Each recreational point could also be combined to hold both parks and playing fields so each recreation point could serve a variety of activities.

By making these assumptions some guidelines are set down as to the overall development of the site, thus making it work as a cohesive community of three to five hundred families, yet also breaking the community down into smaller more intimate developments where a sense of neighborliness can occur with a certain sense of vitality.

**TRANSLATION OF CRITERIA INTO DESIGN FORM**

---

The following is an attempt to look at the preceeding research and criteria dealing with traditional housing and begin to develop senarios of a sort, thus beginning to touch upon a hypothetical housing development and various aspects of this development. A few general design types with respect to entry and grade as well as a few typical floor plans have been looked at. Examples of massing have also been studied. Finally, a schematic sample area from the over all development has been shown with various images relating to portions of the development.

#### DESIGN TYPES

By using more than one design type, one is able to adjust to the variety of grade conditions on a particular site and helps to provide a variety in the architecture including density, mass, and individual identity (rooflines).

## SLAB-ON-GRADE/CRAWL SPACE

This type is best suited for a flat site. It may or may not have a second level. How it relates to the flat grade makes it possible for easy access to the outdoors. This type is most beneficial to the elderly because of this reason.

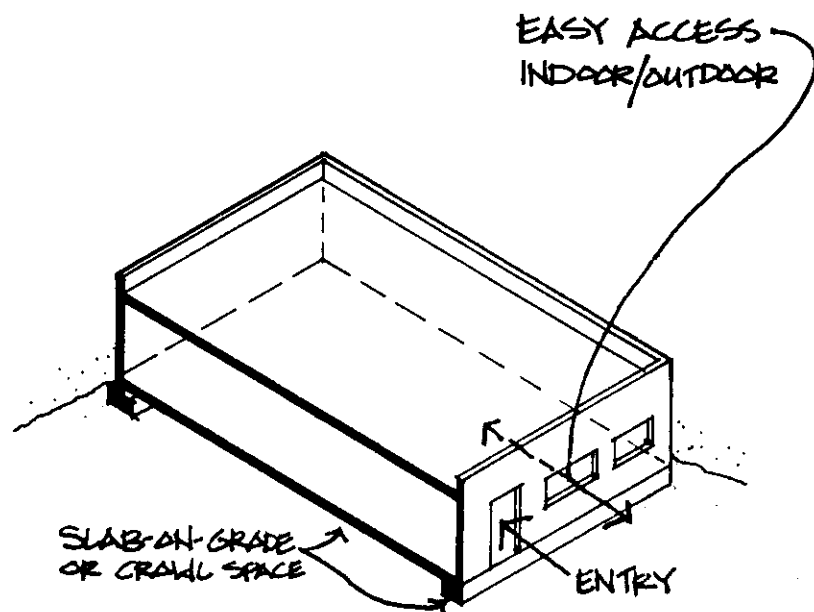

## BASEMENT/WALKOUT

A design type with a basement creates even more livable space than the slab-on-grade/crawl space. The basement could be either a non-walkout or an even more desirable walkout unit. If used as a walkout, a higher quality living space can be created than with a non-walkout. The walkout also enables this type to adapt easily to a sloped site. The walkout also creates a three-story effect if the unit is a two-story unit at the entry side. Balconies and decks can be used to help scale this down.

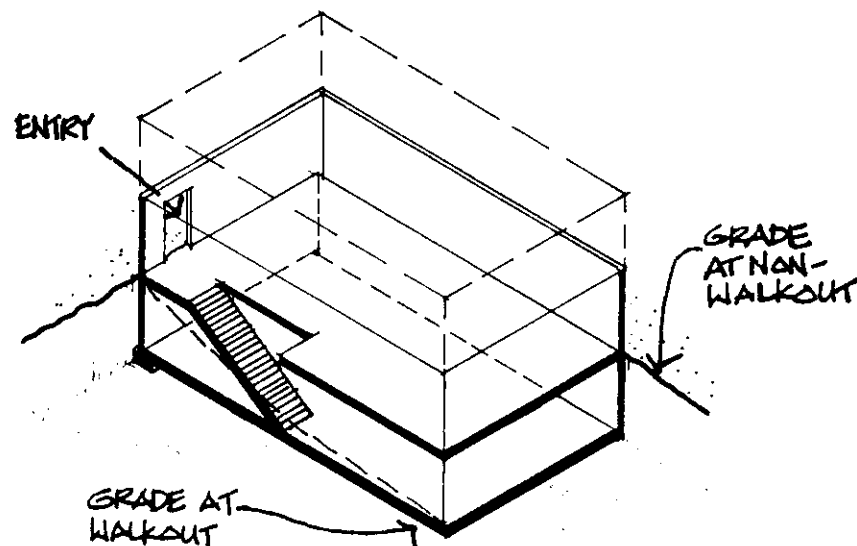

## SPLIT-ENTRY

This type is basically the same as the basement/walkout unit with the exception of a split entry. A plus of this type is that it creates less stairs to climb between levels and adapts to sites with a relatively low slope or can be used to easily create a lower slope on a flat site. It can also cut down on the over all height of a unit, thus allowing the unit to appear less massive.

## GARAGE

The garage type allows the owner to enter the unit from the lower side. Another entrance at the secondary level is located at the other side. By creating a garage tucked under the unit, less land area is used thus making for a more economical development than if parking is located elsewhere. Also, less natural land is being disturbed. An outdoor deck is shown with this type.

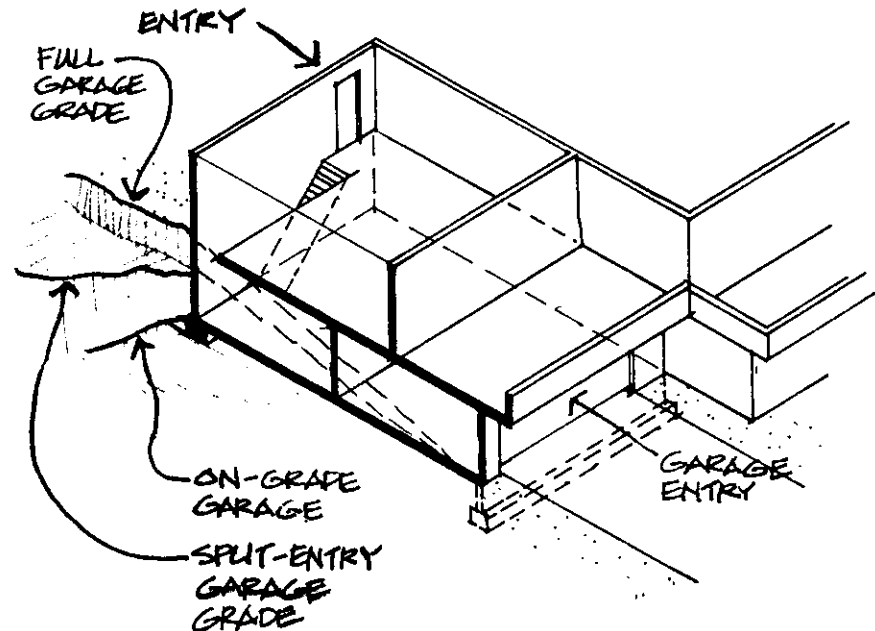
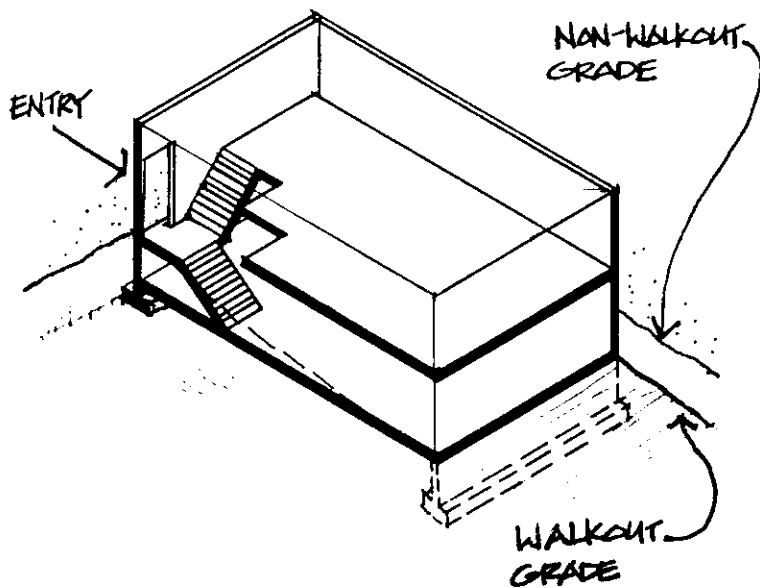

# TYPICAL FLOOR PLAN

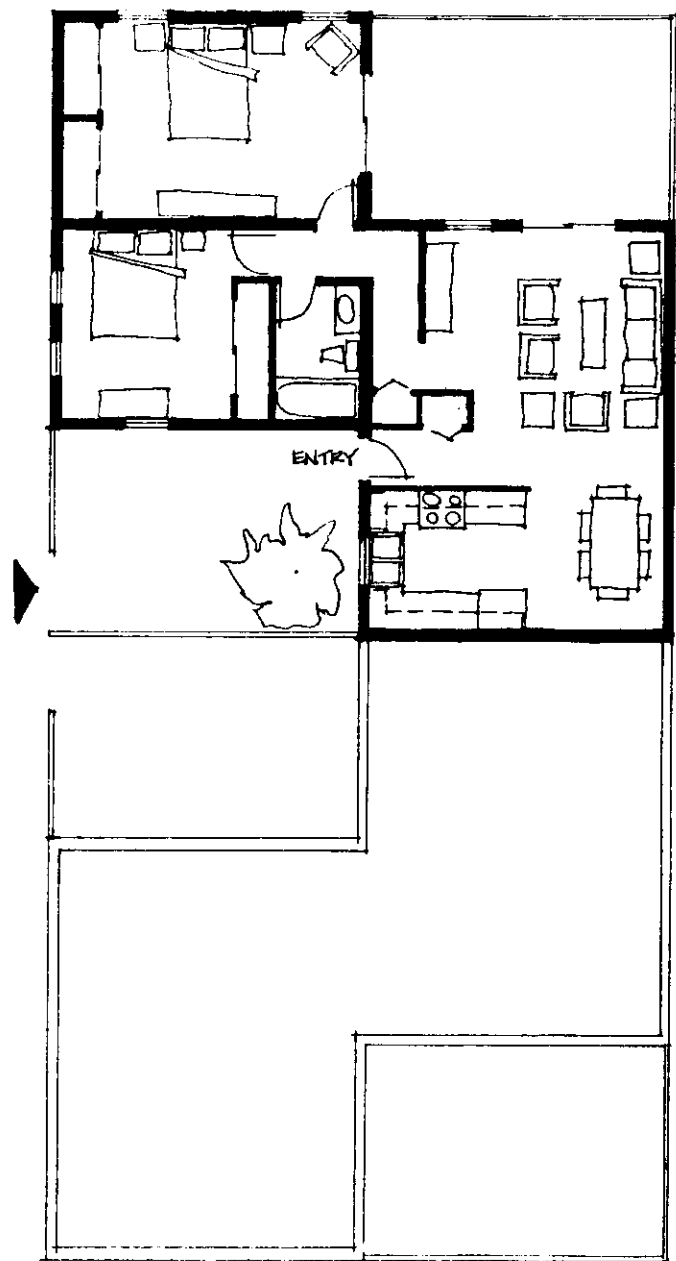
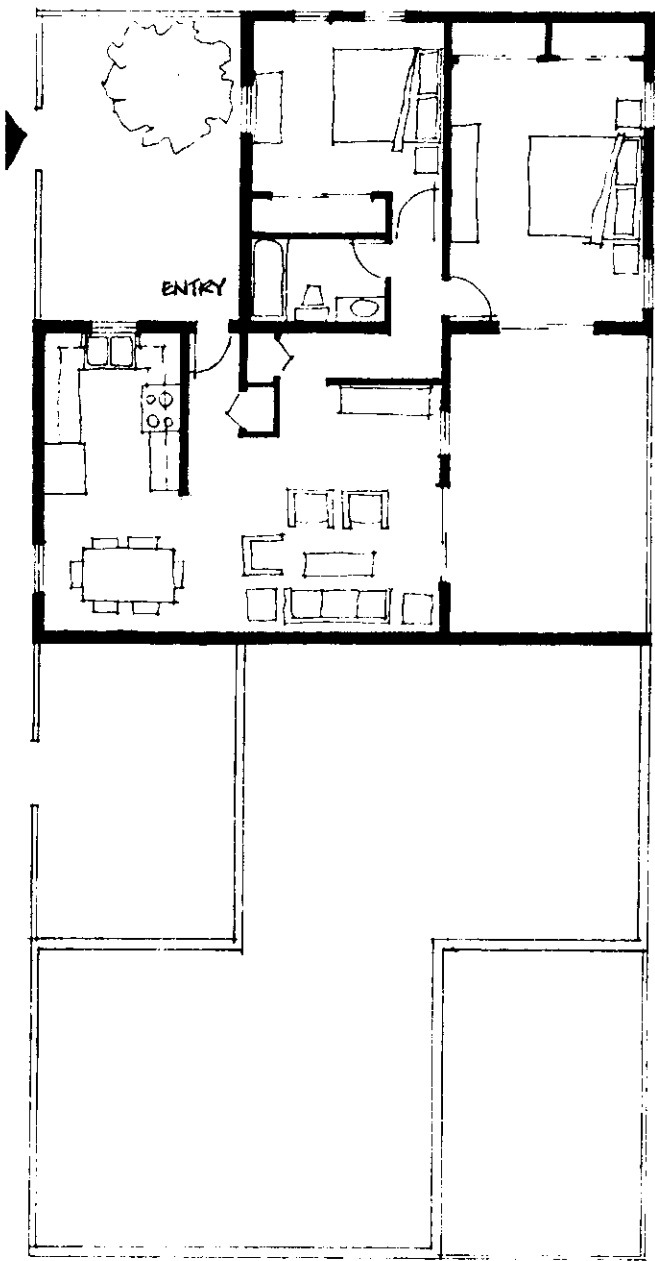

# MASSING

The plans on the preceding page show a basic floor layout with two different possibilities of connection with neighboring units. At the right are those massing possibilities on a larger scale. Shown are only a small number of massing/grouping schemes possible. Through arranging and combining the basic units, endless possibilities are possible. The top two massings each show six units grouped together with the main entrances to each unit through courts at the sides. Interior courts are located back-to-back.

The bottom two massings show six units grouped in twos with pedestrian access running between horizontally. These units could be entered through courts either from the side, from the back (as shown), or from the front. Private courts are shown protected on two or three sides by the surrounding units. The dashed lines represent pedestrian circulation patterns.

In both cases the massings of six units could be grouped together to make up a larger massing with vertical and horizontal pedestrian pathways located between each massing of six. These units were designed with a sloping site in mind. Even though they could obviously be used on a flat site, views would be best if these units were built on a sloping site. Growth is possible by enclosing the secondary court.

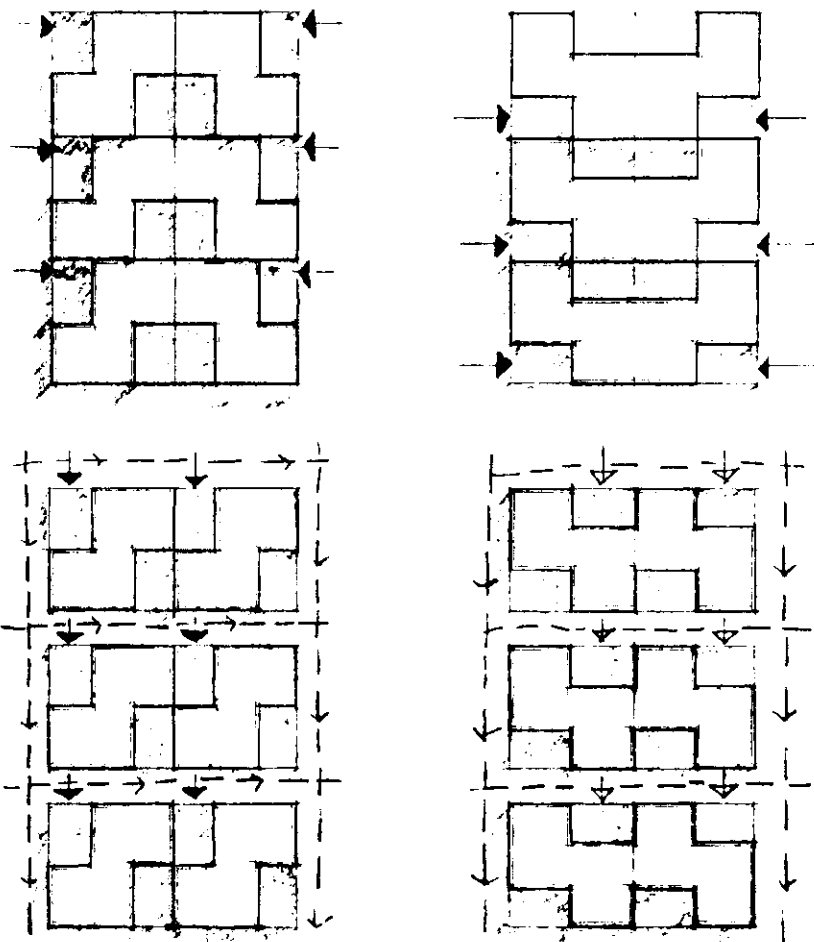

The following groupings show a higher density massing of units than shown on the preceding pages. These step-down units would be built on a sloping site as shown on the sections. Each unit would have a deck with or without a trellis overhead. The lower units would be entered at the lower end of the massing, whereas the upper units would be entered at the high end and some units entered at an upper level by the use of stairs and an upper walkway. Another possibility is for the entrances to the end units to be on the sides. The units could be massed in several ways with different levels in order to vary the skyline and over all look of the unit grouping.

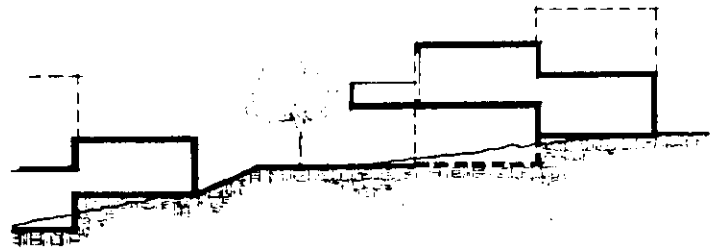
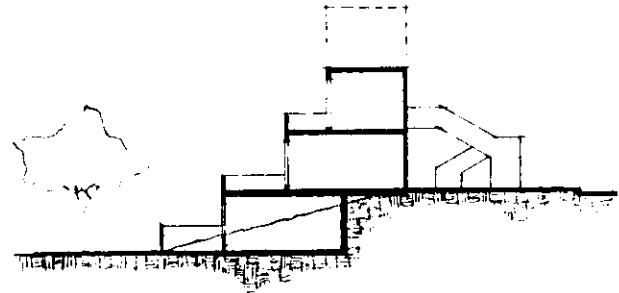
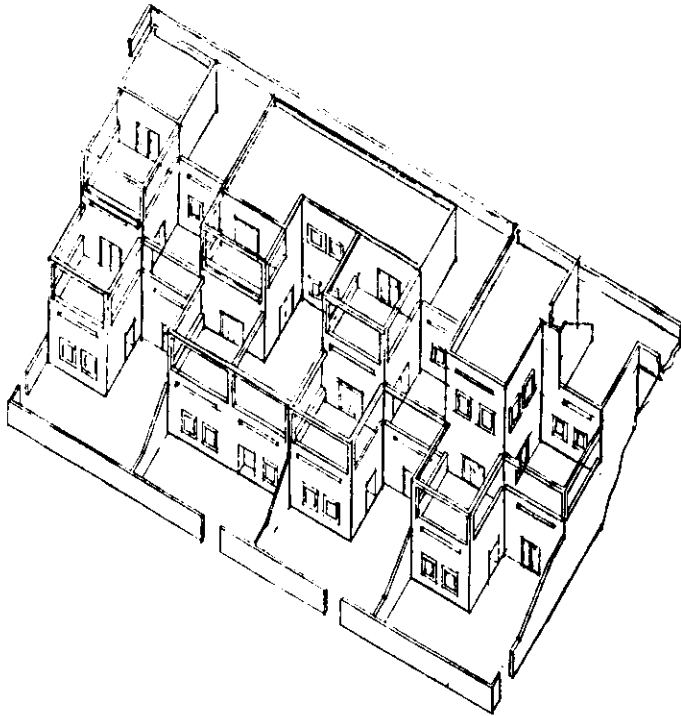
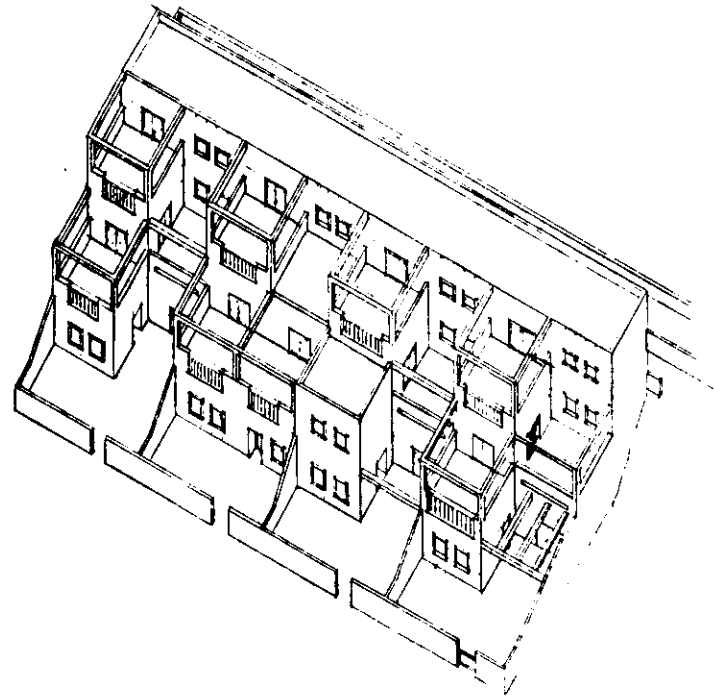

# PARTIAL SCHEMATIC SITE PLAN

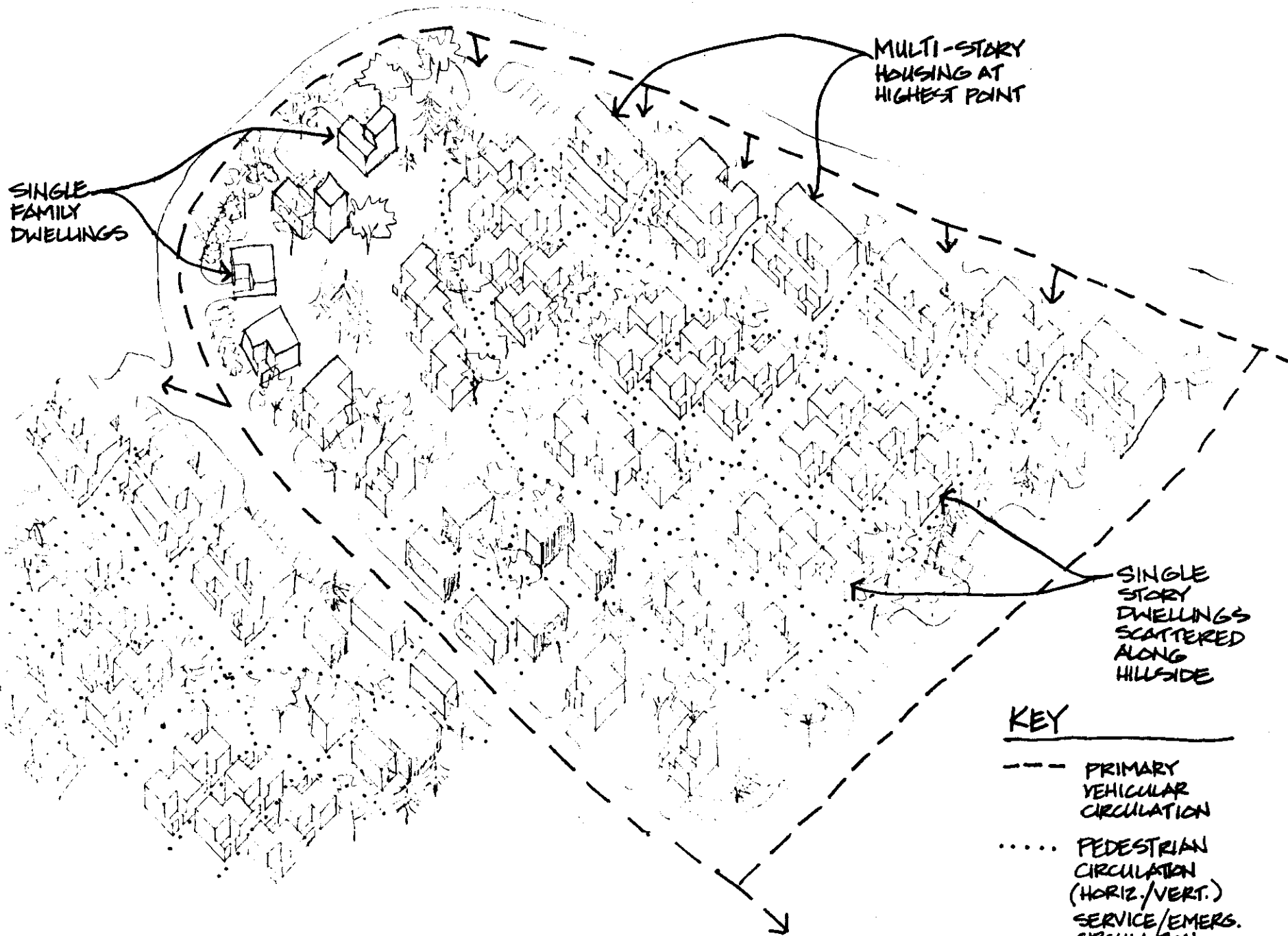

SINGLE FAMILY DWELLINGS

MULTI-STORY HOUSING AT HIGHEST POINT

SINGLE STORY DWELLINGS SCATTERED ALONG HILLSIDE

## KEY

- PRIMARY VEHICULAR CIRCULATION
- ..... PEDESTRIAN CIRCULATION (HORIZ./VERT.)
- SERVICE/EMERG. CIRCULATION (HORIZ. PATHS ONLY)

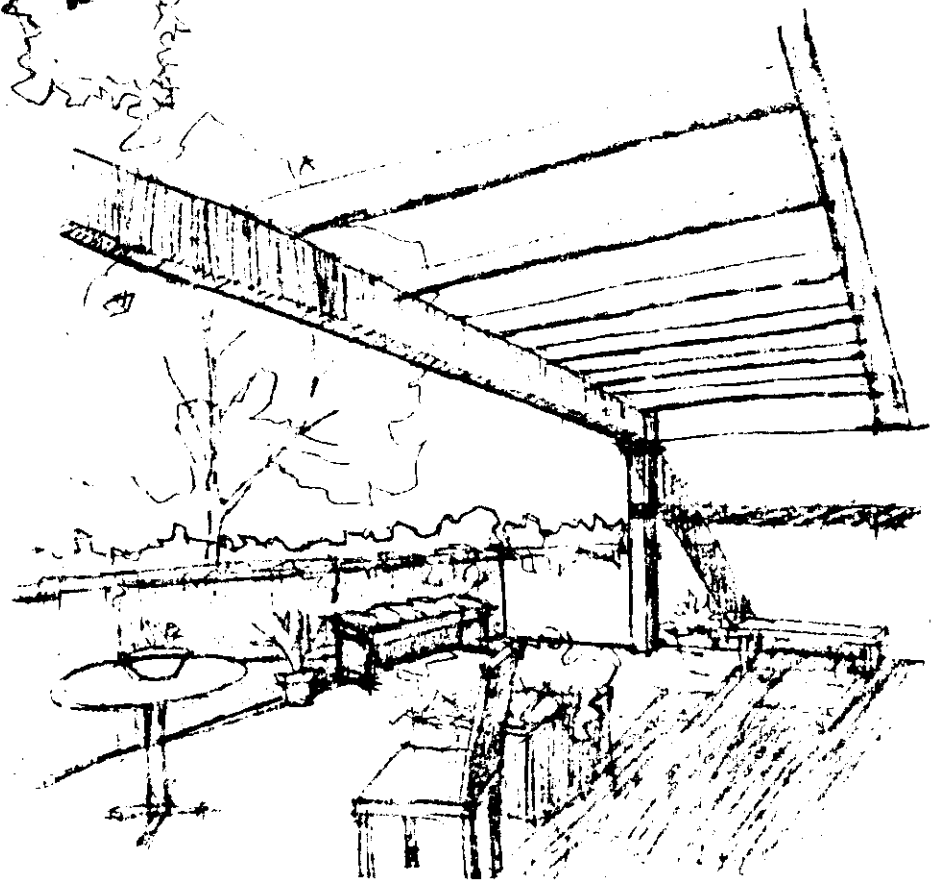
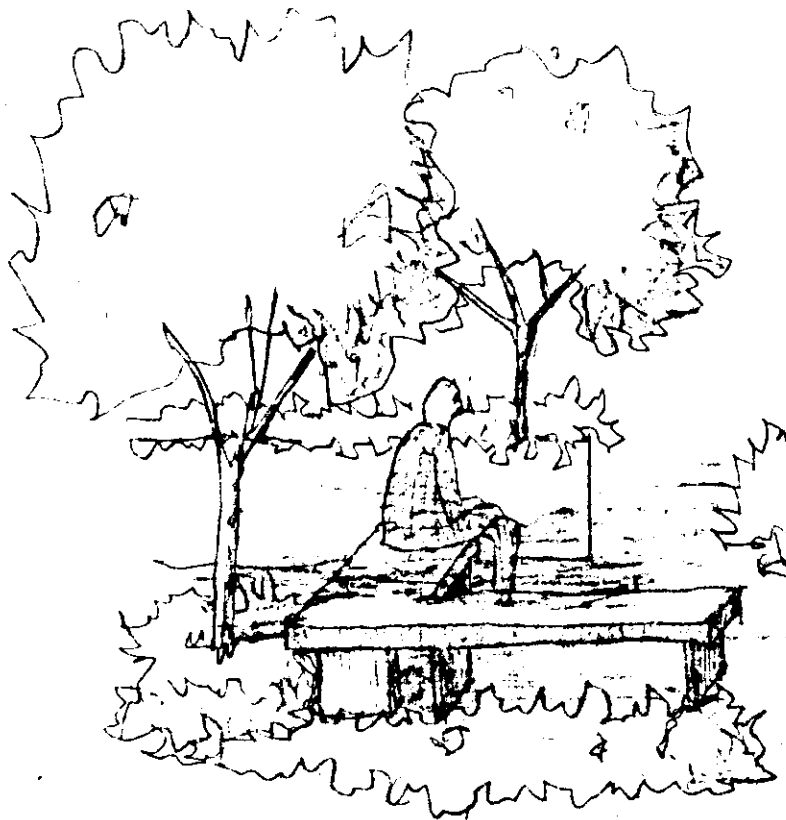

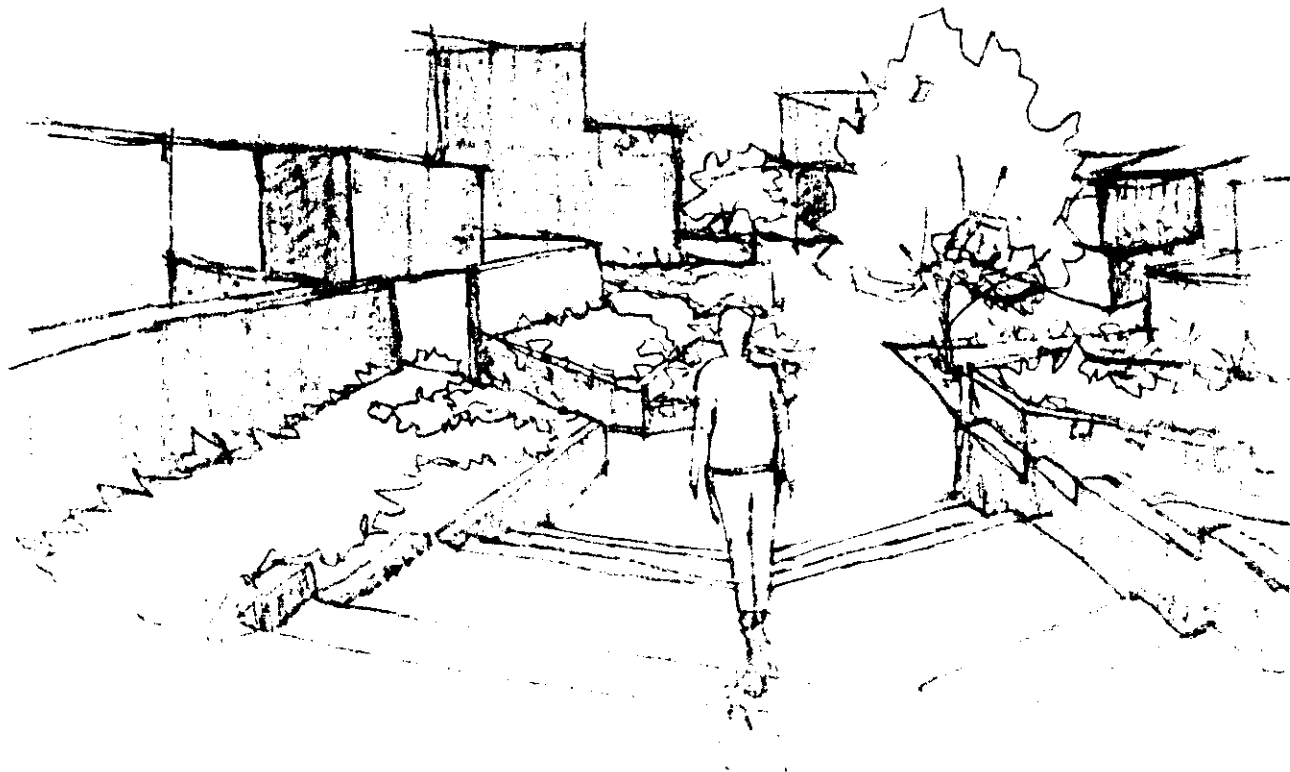

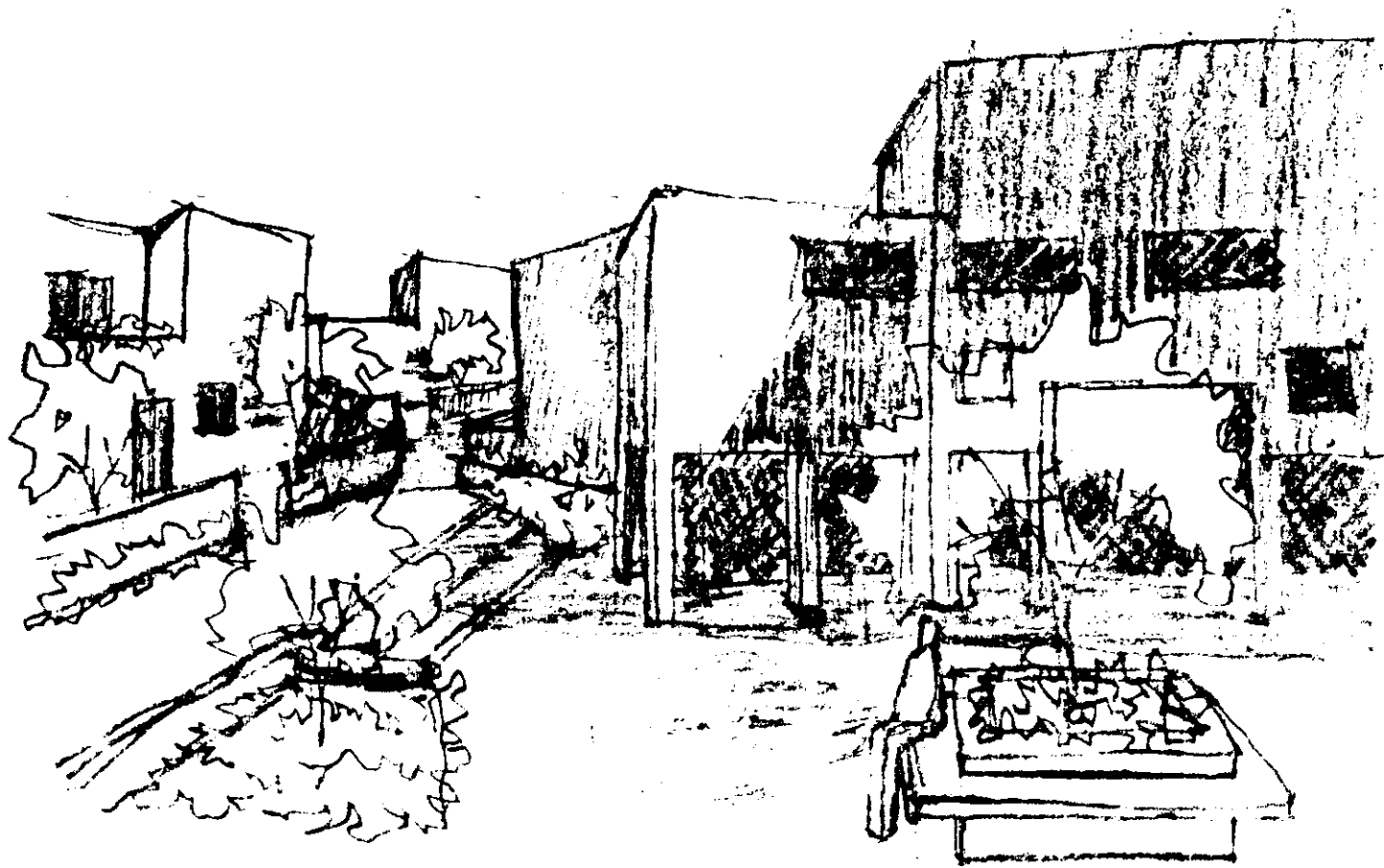

**THESIS INSIGHTS AND CONCLUSIONS**

---

This project has given me the opportunity to study and research in-depth a subject I had great interest in, but little knowledge. I had some preconceived ideas on housing in Jerusalem before I began my studies. I was naive enough to believe that many other countries, including Israel, had a housing situation similar to the United States. I was wrong. Apartments in the U.S. have the people who live in them, but provide little more save athletic and leisure facilities. Many Americans have the luxury to live in suburbs in single family dwellings. We have the land; therefore, we build and build homes of our own.

In Jerusalem, and many other cities in the Middle East, land is more scarce. People live quite differently. There are mainly apartment styled dwellings for people to live in. While in Jerusalem, I saw only one small new development of single-family homes and I imagine they were rather exclusive. Many families in Jerusalem have settled into what are called satellite communities. These communities dispersed around the outskirts of the city are in a way "suburbs" in themselves. They are large blocks of dwelling units massed along the hillsides. They, like U.S. suburbs, are virtually self-supporting. They contain their own religious facilities, schools, small shops, etc. all within a much smaller area than U.S. suburbs as we know them.

I feel lucky that I was able to live within the Israeli culture for a short while and to get a firsthand look into the traditional and contemporary housing that exists there. I regret that I didn't have more time than

to take walking tours through these developments. It would have been beneficial to talk to the residents themselves about their particular living habits.

I viewed this project as a whole to be a package of guidelines to follow when developing new housing developments. I feel that I was successful in breaking down the existing elements that make up traditional housing developments in Jerusalem. I feel that these are strong elements that add vitality and a sense of culture to Jerusalem and should be preserved in modern architectural housing developments. True, contemporary housing has to keep up with the needs and technology of the day, but it should also reflect the culture to which it belongs.

It would be beneficial to be able to take part in an actual housing development project in Jerusalem in order to implicate my research and guidelines. I hope someday I will get to do just that.

**APPENDIX**

---

## REFERENCES

---

### EXPERTS IN THE FIELD

Dr. Naomi Carmon: Professor of Sociology,  
Technion, Haifa, Israel.

Ronen Kishon: City Planner, Jerusalem,  
Israel.

Arie Rohamimoff: Architect, Jerusalem,  
Israel.

Yaron Turel: City Planner, Jerusalem,  
Israel.

### PUBLICATIONS

Beyond Habitat, by Moshe Safdie  
Cities, The Forces That Shape Them, Ed.  
by Lisa Taylor

Feeling and Form, by Susanne K. Langer

The Form of Housing, Ed. by Sam Davis

The Hidden Dimension, by Edward T. Hall

House Form and Culture, by Amos Rapoport

Jerusalem Architecture: Periods and Styles,  
by David Kroyanker

Jerusalem City Plan, by Henry Kendall

Jerusalem Planning and Development 1979-  
1982, by David Kroyanker

Jerusalem Planning and Development 1982-  
1985, by David Kroyanker

Man and His Environment, by W. Michelson

The New Jerusalem-Planning and Politics,  
by Arthur Kutcher

Psychology of the House, by Olivier Marc

Shelter, Sign and Symbol, Ed. by Paul Oliver

Shelter and Society, Ed. by Paul Oliver

The Urban Villages, by H. Gans

# ADDITIONAL INFORMATION

10-27-85

HAIFA UNIVERSITY

DEPT OF GEOGRAPHY

DR. JACOB MAHAZ

## SPECIAL ORGANIZATION OF LAND SETTLEMENT IN ISRAEL

- Schematic layout of <sup>dense</sup> nucleated villages in Israel (Arab)



\* traditional Arab village

out settlement (for individual farming)  
for agriculture dry farming

usually located on small hills for sanitation (drainage) security

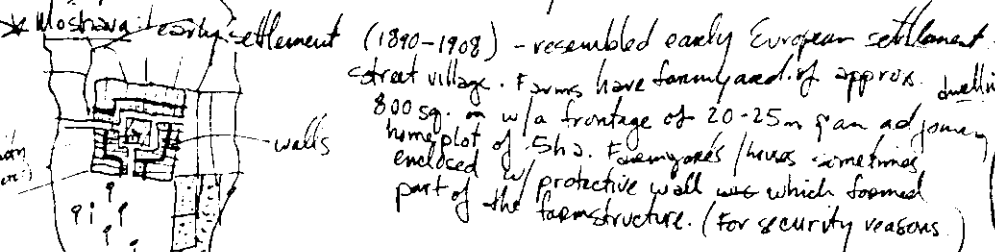

## KIBBUTZ

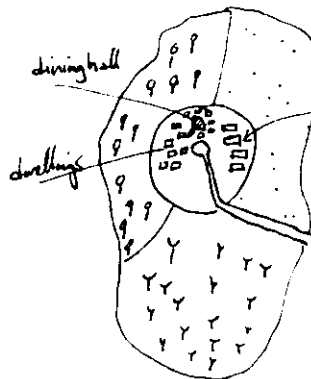

- no need to subdivide land
- keep population w/in the kibbutz
- social problems (cabin fever, lack of privacy)

## MOHAV SHITUF (collective Moshav) 1930's

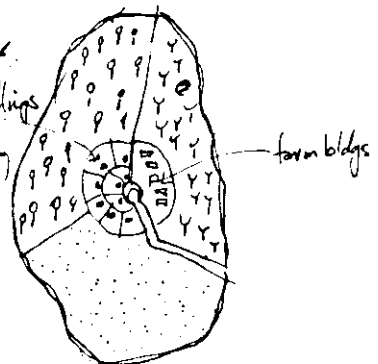

- has more privacy
- no dining hall
- can use it how you want don't have to share it w/ rest of settlement.
- lacks internal discipline like kibbutz.

- New settlements now not only based on agric. now based on industry also

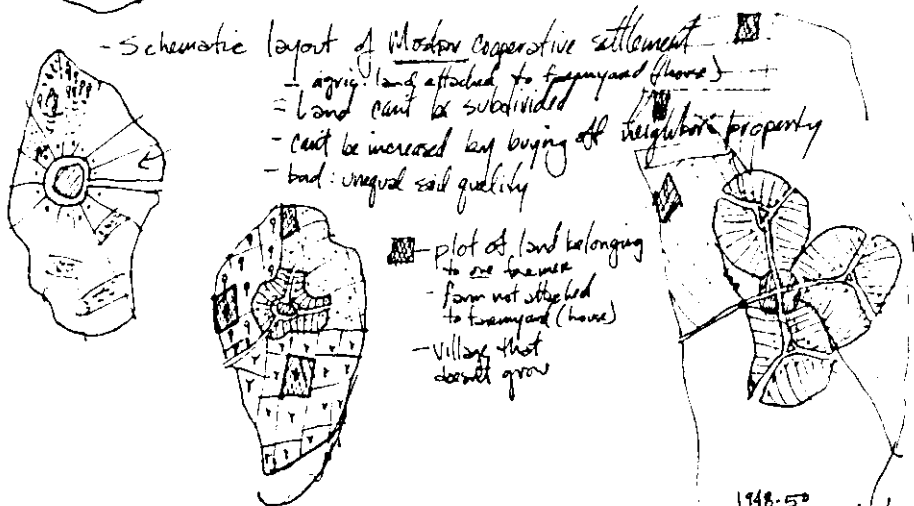

1948-50  
Multi-Nuclear Moshav.

A.P.

4.25.86 - Fri

P. 2  
4.25.86 - lecture

Response of Arch. to context

\* context creates richer environs

- climatological (hearth, sun, wind)
  - topography (soil types)
  - sociological
  - (hist.) past effect on bldg. environ - heritage.
  - arch. overlooking context - reduction
- variety of contexts - combo → unique

5 climatic conditions

→ Mediterranean to hot desert

Soc. context

→ diff. soc. groups. 4000 yrs. of bldg.

2 projects - A.P.'s working on

- 1 km x 1 km - Old city (desert to east)
- relig. very strong in Jerusalem.
- comb. of diff. styles / periods. - mosaic ("ethnic goldash")
- layering of arch. elements by

Climate  
coming to from east - desert area (5-10 inch. rain)  
" " " " west mediterranean climate -

both meet @ ridge of Jerusalem

Projects: entrance to old city from east - Via Dolorosa (Lion's Gate)  
→ inside entrance (by Temple Mt.)  
• accentuate - pilgrim's route to Via D.

simple / relating as possible to relig. historic qualities.

3rd project - promenade - from Lion's Gate to gate on south  
west wall of Old City - pool originally  
make into amphitheater - stage, etc. incorporated

acoustics - another aspect - <sup>used</sup> <sup>judiciously</sup>  
temporary shed - contrast to environ. - taken down every oct. (up in spring.)  
permanent elements - "one" w/ environ.  
50,000 people

3rd. project.

Pamot → recent neighborhood - Jr.

- encapture open / bldg. form val. of.
- bldgs - diff in size (narrow spaces & open sps.)
- 2000 bldgs.

define per. of bldg. w/ housing - sun room, yard,  
- w/ parking.

15 diff. hsg. types

fixed pt. of 100 sq ft terrace for each  
dwelling.

2-3 bedrooms - surrounding terrace

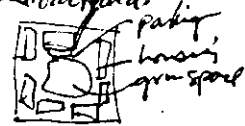

Tel Aviv - housing

narrow streets (sometimes 15 ft.)

integrated urban sts. - both

→ using several elements (arch.) park / street  
to call out separate dwelling



Hsg. types accord. to climate conditions. - Clusters

humid areas → [diagram] wind can go thru

arid → [diagram] wind storms

normal → [diagram]

Arabic house [diagram] - shade from arcade in summer. absorb radiation

P. 3 4.25.86  
lecture.

west & north →

south → most openings

Kinetic trombe wall → 

rotating prism

one side → absorbs heat - black.

" " → reflects heat - white

" " → takes out heat from interior / lets heat in in winter.

improving on kinetic trombe wall

blk. side rotate to either reflect / absorb heat.

white side

(at Ben Curio - trombe-bldg - amphitheatre, class rooms.)

Solar shading

pergola

30°

• in winter - lets sun in

• in summer - shades -

\* tell us about your housing. Point:  
• density patterns today

→ what things to concentrate on?

→ am I heading in the correct direction?

→ any other pts. I should hit?

6000 yrs. of housing by Norberg-Schulz (Schulz)

housing → occidental - facing outward

intro-reflective -  
oriental →

→ density - not much of density

→ equal

→ dwell / per acre.

→ people / acre.

→ see St. Louis.