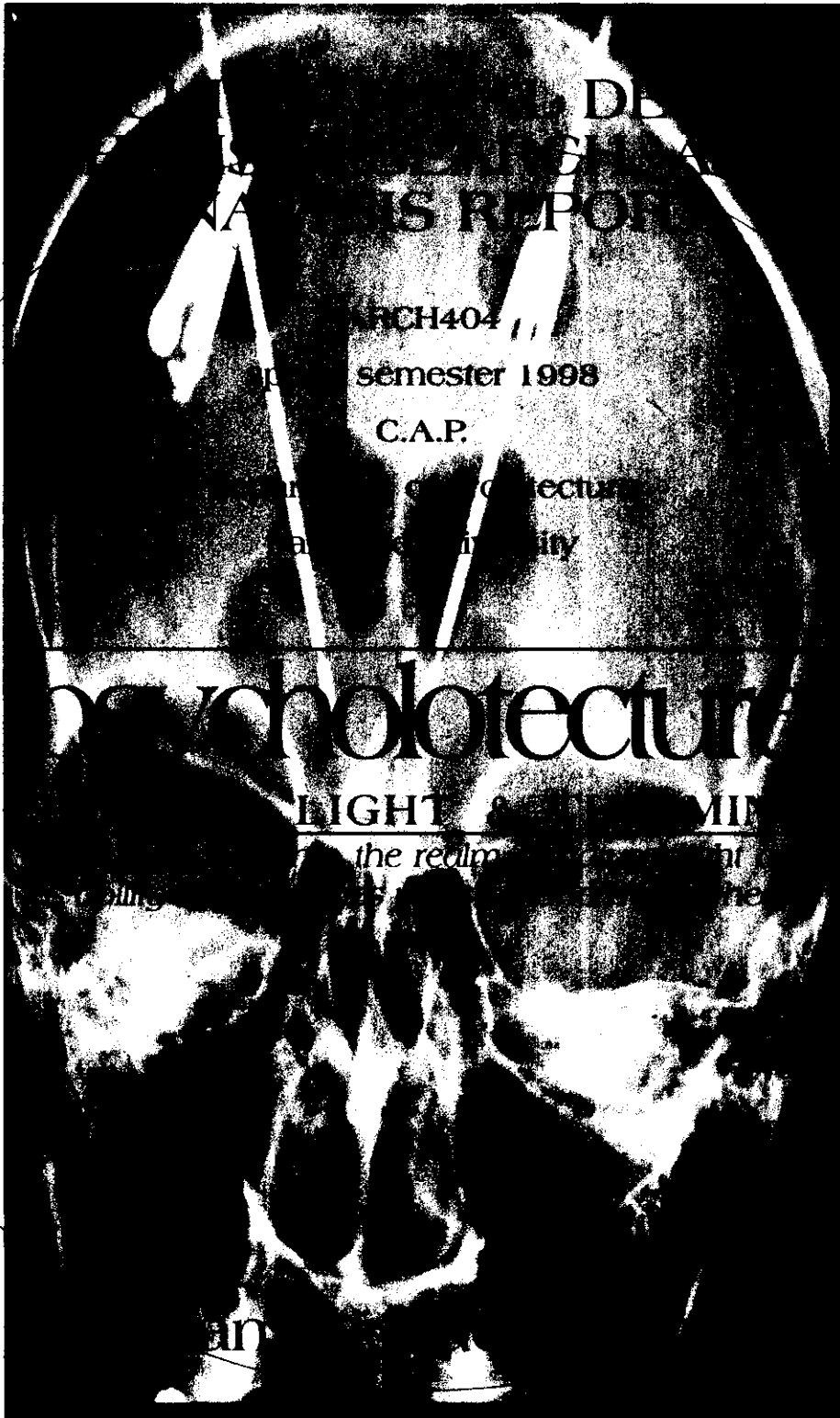


Arch
Thesis
to
2002
2002
1998
1997

brian m. parker ARCH404 architectural thesis book spring 1998

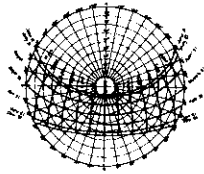


THESIS
RESEARCH
AND
ANALYSIS
REPORT

"As sunlight falls around a helpless thing, revealing form and order, so a corresponding light, of which the sun is a symbol, shines on the inspired work of man"

Frank Lloyd Wright

psycholotecture...



brian michael parker

psycholotecture

NATURAL LIGHT & THE MIND

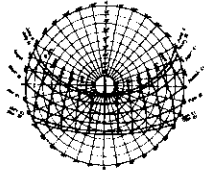
*an investigation into the realm of natural light and
it's ability to affect ones physical and mental health*

*solar light therapy retreat center
outside of phoenix, arizona*

may 1998

psycholotecture...

02.



department of architecture
college of architecture and planning
ball state university

brian michael parker

psycholotecture

NATURAL LIGHT & THE MIND

*an investigation into the realm of natural light and
it's ability to affect ones physical and mental health*

bachelor of architecture degree program
thesis design

A. Seager

architectual design studio instructor

P. George

architectural professor __ thesis critic

©1998 brian m. parker

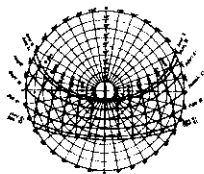
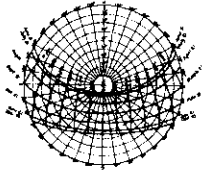


TABLE
OF
CONTENTS

05. abstract
06. thesis issues & positions
07. thesis research
14. experiment with sunlight as form generator
15. ortho graphic sun tracking model
16. preliminary solar studies
22. historical and physical context
23. site reports
27. design development
29. final design solution
36. final design solar studies
40. final design interiors
42. image notation
43. working bibliography
44. credits
45. notes

fig. 002



Since the dawn of man humans have maintained a consistent connection with the sun. as architecture evolved, so did the role that natural light played in the design of structures. these days, the sun has lost it's position high atop the list of essential design criterion. from office buildings containing hundreds of cubicles and core offices, to eliminating glazing as a means of cutting building costs, architecture lost it's relationship with the sun. this thesis is a tool for designing a possible way of reconnecting humanity with natural light through architecture. the design will act as a prototype for a new building precedent. it will take the shape of a light therapy retreat. the premise is that humans rely on sunlight for basic survival. as the building industry continues to limit the role of natural light in architecture, society has begun to suffer both physically and psychologically. citizens who become afflicted with symptoms of sun depravation would be referred to the clinic for treatment. the general criteria for the retreat center is that people will interact with natural light in a variety of ways throughout the day. no space will be without sunlight in some form. light becomes the driving design ideal and plays a vital role once again in the creation and character of the architecture. mankind shall not be deprived of man's oldest medicine, the sun.

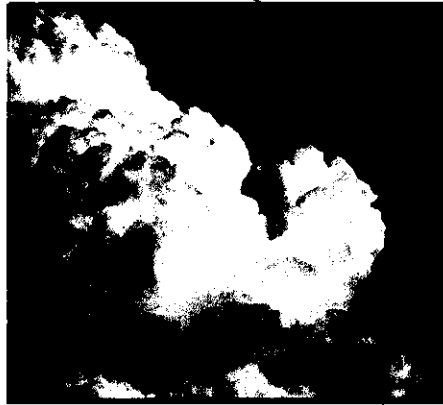


fig. 003



fig. 004

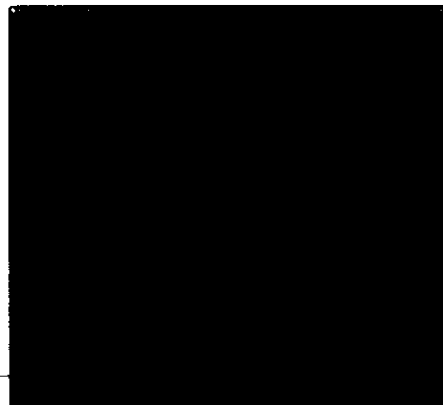
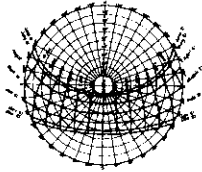


fig. 005

ABSTRACT

psycholotecture...

05.



Sunshine is a vital key to the survival of mankind. it warms us, allows plants to grow and oxygenate the planet, and provides the earth with food. aside from the basics, the sun plays an even more elemental role in our survival...

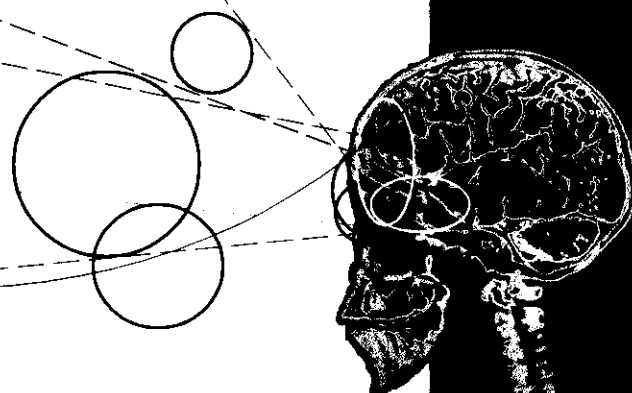
"it keeps us healthy in both MIND and in BODY"

as humans we require vast amounts of natural sunlight to maintain and regulate many of our bodies functioning systems. these include both physical and mental elements. "how can designers use and harness the healing powers of natural sunlight to influence architecture?" factors such as site, structure, systems, and life cycle costs are typically at the forefront of a designers mind. what about questions like "how can one manipulate space to provide for the highest amount of physical and mental healing to occur?"

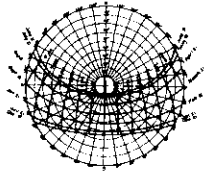
Health and wellness as an overall concept differ from person to person. this does not mean, however, that there are no elements of health which can effect everyone. the benefits of sunlight are some of these elements. the idea of perception is another factor which varies from person to person but there are several constants which are similar to all. the concious and subconscious perception of natural light and the obvious power it has on the human body as well as the psyche is one of these constants. **PSYCHOLOTECTURE** represents the integration of this idea of psychologically perceiving that one is healing both the mind and body into the design ideals of architecture. physically and psychologically enhancing spaces with the inclusion of natural light into the design concept. "is there a set of criteria which can be developed by architects to integrate these ideals into a design?"



fig. 006



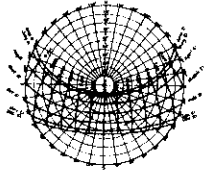
THESIS
ISSUES
&
POSITIONS



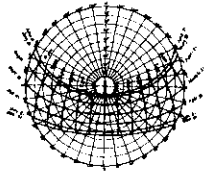
Natural light is the quintessential element of timeless Architecture. If light is "the giver of all presence," it can be postulated that natural light is the soul of a place. Its luminosity clarifies the mental as well as the physical realm, the prosaic as well as the poetic, the profane as well as the sacred. This soul is sensed by the observer and leads to immediate knowledge of the space (Lakeman 20).

Sandra Davis Lakeman stated that natural light "is the soul of a place" but it plays many other crucial roles in the ever expansive field of architecture. It allows us to see, it keeps us warm in cold weather, and it helps wonderful green treasures of nature to thrive and grow. Natural light may be the quintessential element of timeless architecture but it is quite often overlooked for its important role in the building industry, promoting good health and well being. Although seldom used as a design essential, the inclusion of natural light in buildings can greatly help to promote good health, well being, and increase ones overall enjoyment in a particular built environment.

Before one can asses the value of bringing increased amounts of light into structures the various needs the body has for it, as well as the negative aspects of insufficient amounts must be properly analyzed.

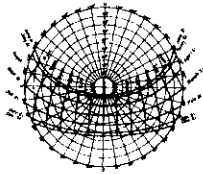


To understand better how the body reacts to natural light a scientist named John N. Ott experimented on cells of elodea grass. He discovered that each cell would perform in an established pattern when exposed to any natural sunlight condition. Mr. Ott's studies progressed to later discover more and more of the effects of natural sunlight and its positive effects on mans health (Ott 4-5). Every human has a photobiological need for natural light. This need pertains to a vast list of systems and functions throughout the body including glucose balance, growth hormone levels, as well as numerous other areas of body activity. Mans social, psychological , biological and behavioral health are heavily influenced by light (Spivack 10,67,75). Another aspect of mans need for natural light is for the production of a vital chemical known as meletonin. Often discussed in conjunction with a common health problem known as SAD [Seasonal Affective Disorder] syndrome, the decrease in meletonin occurs when sun light levels drop below 2,500 lux. A decrease in the production of this chemical is known to produce such disorders as severe depression and societal withdrawal (N.I.H. 78). Some final negative effects of decreased amounts of natural light on the human mind and body are that of weight gain, over heating, alcoholism, and the disruption of personal relationships.

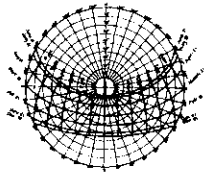


With a knowledge of the bodies needs for natural light as well as the adverse effects of receiving an inadequate amount, some of its positive attributes may be explored. The first, and maybe most important, human reaction to sunlight is that of increased visibility. A dionysian reference states that "sunlight is the progenitor of life. Without it life would cease to exist, and cease to see" (Slagan 6). Natural light is proven to reduce eye strain from florescent light and is actually considered healthy exercise for the eyes. One problem of artificial light is that it often produces harsh shadows and excess glare, but natural sunlight is often a more balanced and clear form of light. Studies have shown sunlight can also have very positive effects on some common health problems as well. Physiological problems such as depression may be greatly improved with light therapy as well as P.M.S. and jet-lag.

It can be said that natural light plays a major role in our lives by helping to keep us healthy and happy but how is this linked to the practice of design and of architecture? A starting point in making this connection is to look at the office environment and how the inclusion of natural light plays an important role. To begin one must know the bases behind a principle factor referred to as the Circadian Rhythm. This "rhythm" is essential to the body to regulate its systems and to



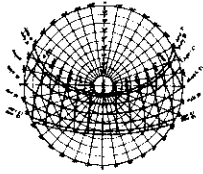
optimize synchronization of our natural cycles; sleep times and awake times. The regulation of the Circadian Rhythm is achieved by allowing enough natural light into an office environment thus allowing the brain to acknowledge that is indeed on the awake, daylight, portion of the cycle and responds by maximizing alertness. Many people who work in offices with little or no natural light begin to feel indifferent toward their jobs and suffer from extreme lack of productivity. A case study in an office building located in Colorado found that it had shown a 15% decrease in absenteeism and a rapid increase in employee morale after only two months of increasing the buildings natural light admittance. A receptionist at the Rhodes-Patel office building, located in Elizabethtown KY, is quoted as saying "I think all this light is terrific. I am a person who always liked natural light and I feel that it creates a very pleasant and relaxing atmosphere for the people who work and visit here"(I.M.M.R. 27). Another important factor that natural light helps to encourage is that of energetic, productive workers. Society has often felt a great appeal to have contact with the outdoors. By allowing increased amounts of natural light into many of a buildings offices, business owners will find that their employees feel much better at work because they have reached a certain mark of success(Vonier 150). Since 40% of Americas working population are employed within



offices, the overall productivity of the nation is at stake.

Natural sunlight plays a major role in human life. This too is true in architecture. Aside from the logical and economical reasons for the inclusion of natural light into buildings, there is the notion that sunlight can promote well being and good health and it should be integrated into designers philosophies to improve the overall quality of ones built environment.





works cited

Institute for Mining and Minerals Research(IMMR). Kentucky Solar Design

Awards: Photographs and Interviews. Kentucky, 1984.

Lakeman, Sandra Davis. Natural Light and the Italian Piazza. San

Luis Obispo: Natural Light Books, 1992.

National Institute of Health(NIH). Seasonal Affective Disorder: A

Description of the Syndrome and Preliminary Findings With Light
Therapy. Bethesda, 1993.

Ott, John N. Health and Light: the effects of natural and artificial light

on man and other living things. Old Greenwich: John Ott
Pictures, INC, 1973.

Slagan, David M. "The Symbolic Role of Light in Religious Architecture

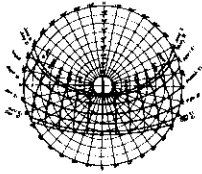
With a Critical Interpretation of Five Churches in Columbus
Indiana." Thesis. Ball State University, 1992.

Spivack, Mayer, and Joanna Tamer. Light and Color: A Designers Guide.

AIA press division, 1984.

Vonier, Thomas, Ed. 1983 International Daylighting Conference.

Washington, D.C., 1983.



works consulted

Holmes, J. G. Essays On Lighting. New York: Crane, Russak & Co.,
1975.

Hopkinson, R.G. Daylighting. London: Heinemann, 1966.

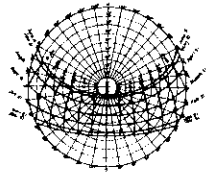
Hyman, Jane Wegscheider. The Light Book: How Natural and Artificial
Light Affect Our Health, Mood, and Behavior. New York: St.
Martins Press, 1990.

Jensen, Tom. Skylights. Philadelphia: Running Press, 1983.

Lynes, J.A. Principles of Natural lighting. Amsterdam: Elsevier, 1968.

Smithson, Alison and Peter. Ordinariness and Light. Cambridge: MIT
Press, 1970.

Walsh, John W. T. The Science Of Daylight. London: MacDonald,
1961.



tower interior solar studies - june 01, 1998



01.

08:00am



02.

10:00am



03.



04.



05.



06.



fig. 008



fig. 009

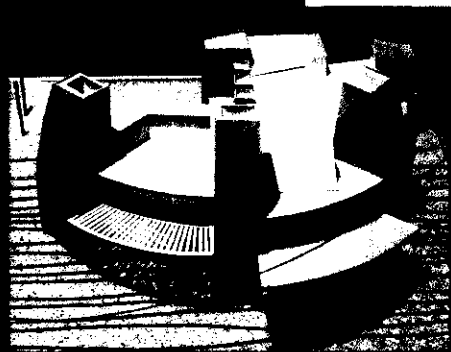


fig. 010

EXPERIMENT
WITH
SUNLIGHT
AS
FORM
GENERATOR

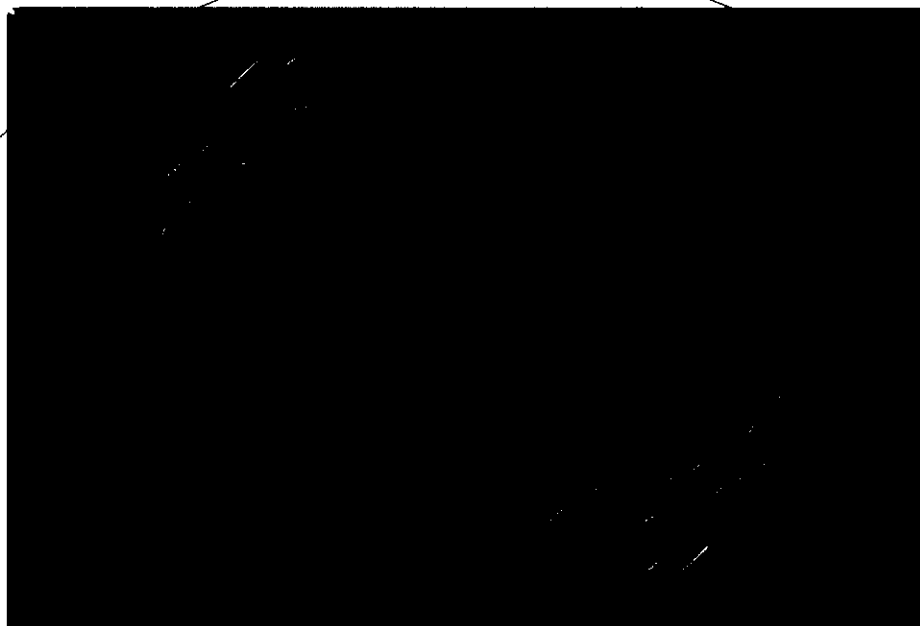
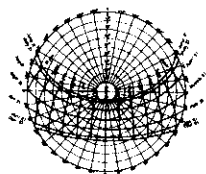


fig. 011

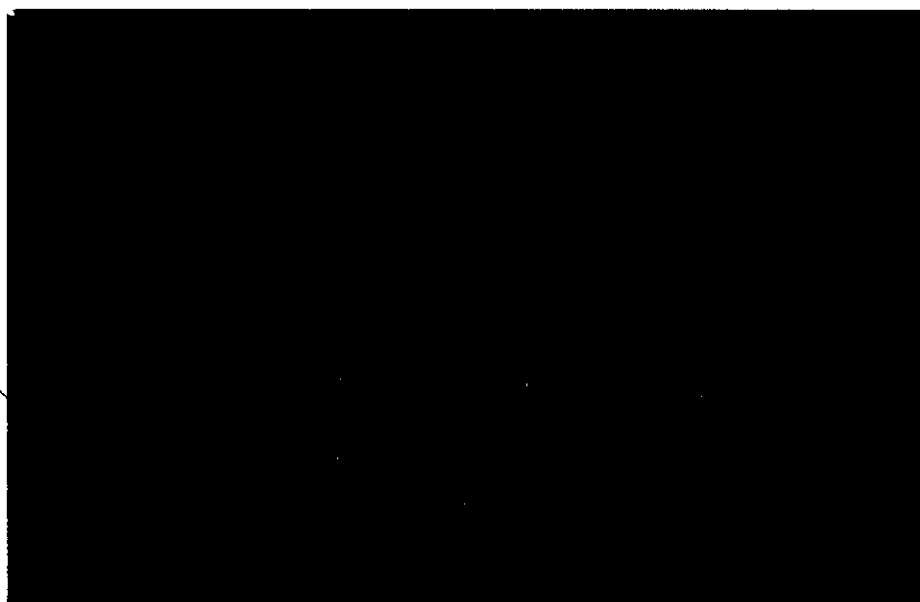


fig. 012

ORTHO
GRAPHIC
SUN
TRACKING
MODEL

psycholotecture...

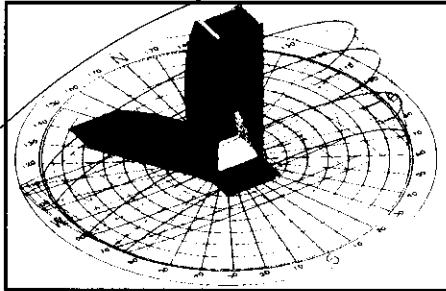
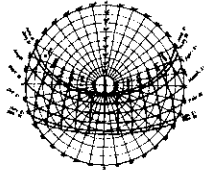


fig. 013



fig. 014

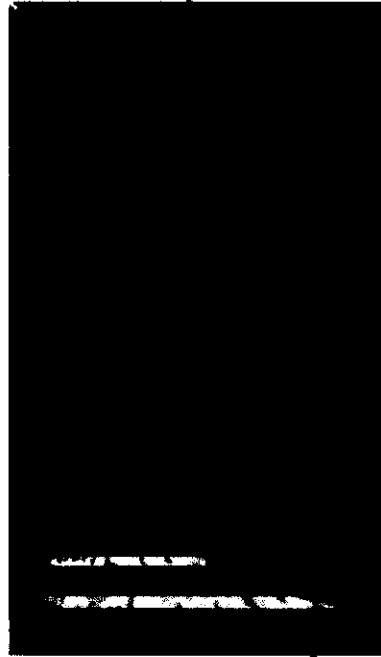


fig. 017

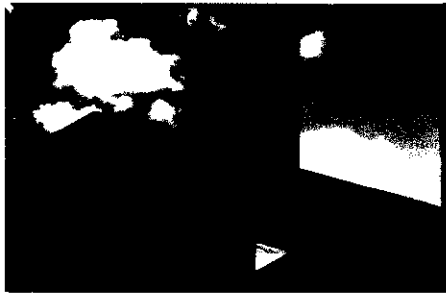


fig. 015

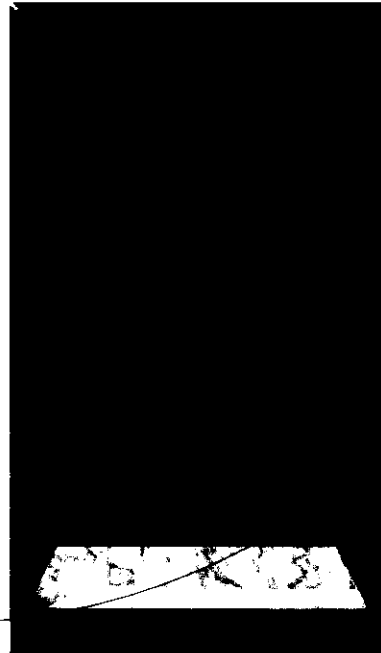


fig. 018

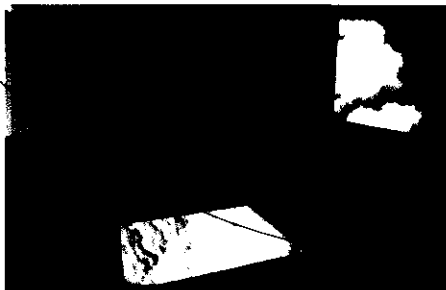
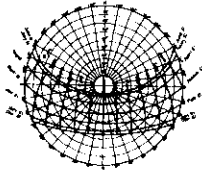


fig. 016

PRELIMINARY
SOLAR
STUDY
001.



description: vertical light-scoop

features: light admitting plane is parallel to ground plane.
interior reflection plane is curved toward direction of sun azimuth.
all reflection surfaces are white.

test results: spring months (march 15 used as average analysis date)
early morning produced general indirect light on reflection surface; characterized as warm glow. full depth of space was minimally perceptible. change did not occur until late morning (c. 10:40a.m.).
noon (including one hour pre/post) glow increased in intensity. projected plane of light on floor. depth perception was greatly reduced but definition of light source was greatly enhanced.
afternoon became the same as early morning.
night (artificial lighting behind reflection surface) displayed full depth of space without natural character.

test results: summer months (June 21 used as average analysis date)
early morning produced general indirect light on reflection surface. change recognizable at c. 9:30a.m.
noon (including one hour pre/post) intense sunlight falling on floor surface. depth of space was unclear. light beams cascading down both walls. intense glow of reflection surface.
afternoon became same as morning.
night (same in every scenario).

test results: autumn months (september 15 used as average analysis date)
the general character of all times was nearly identical to the spring study.

test results: winter months (december 15 used as average analysis date)
early morning produced general indirect light on reflection surface. full depth of space was minimally perceptible. change did not occur until extreme late morning (c. 11:15a.m.)
noon (including one hour pre/post) some increase in intensity of reflection surface. depth of space remained minimally perceptible.
afternoon became same as morning.
night (same in every scenario).

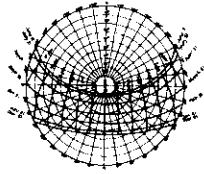


fig. 019

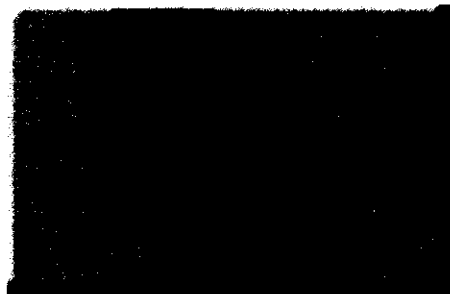


fig. 020



fig. 023



fig. 021

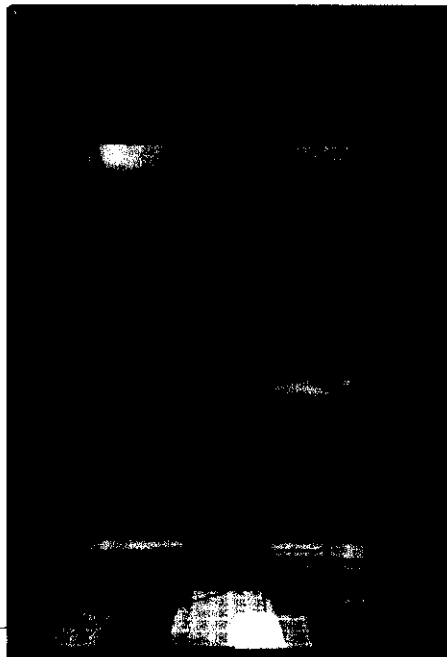


fig. 024

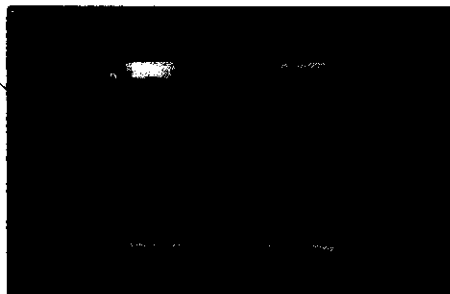
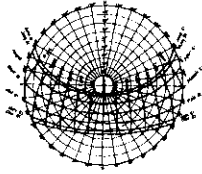


fig. 022

PRELIMINARY
SOLAR
STUDY
002.

psycholotecture...



description: frontal/overhead glazing

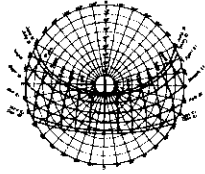
features: interior ceiling surface is curved and reflective.
overhead light entry points are five sided prismatic glass boxes.
frontal glazing is from floor to ceiling.

test results: spring months (march 15 used as average analysis date)
early morning produced general light patterns on floor through frontal glazing. some light patterns noticeable on walls from overhead entry.
noon (including one hour pre/post) overhang prevented most direct frontal entry but maintained strong indirect light. two intense box patterns of light on floor from overhead entry moved in semi-circular rotation.
afternoon became the same as early morning.
night (artificial lighting) no dramatic effects.

test results: summer months (June 21 used as average analysis date)
early morning produced general light patterns on floor through frontal glazing. some light patterns noticeable on walls from overhead entry.
noon (including one hour pre/post) overhang prevented all direct frontal entry but maintained strong indirect light. two intense box patterns of light on floor from overhead entry moved in semi-circular rotation.
afternoon became same as morning.
night (same in every scenario).

test results: autumn months (september 15 used as average analysis date)
the general character of all times was nearly identical to the spring study.

test results: winter months (december 15 used as average analysis date)
early morning produced general light patterns on floor through frontal glazing. some light patterns noticeable on walls from overhead entry.
noon (including one hour pre/post) some direct frontal entry casting long beams of light. two small box patterns of light on floor from overhead entry moved in semi-circular rotation.
afternoon became same as morning.
night (same in every scenario).



PRELIMINARY
SOLAR
STUDY
003.



fig. 025

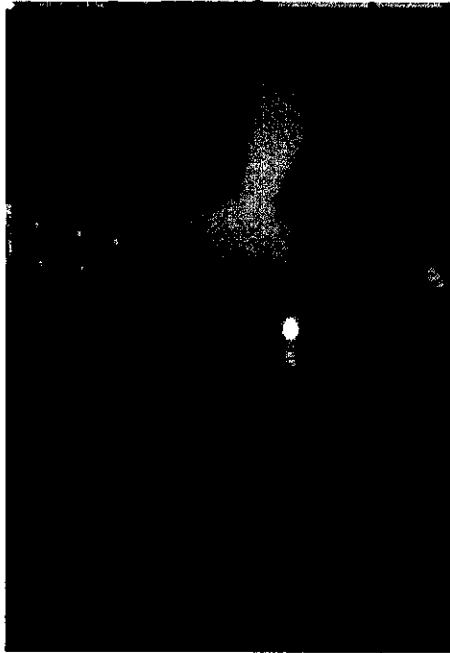


fig. 029

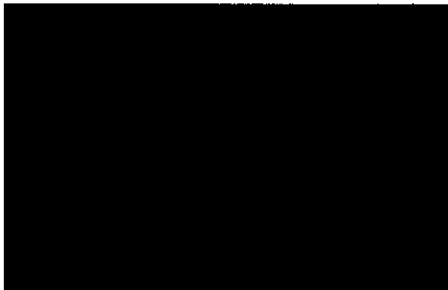


fig. 026

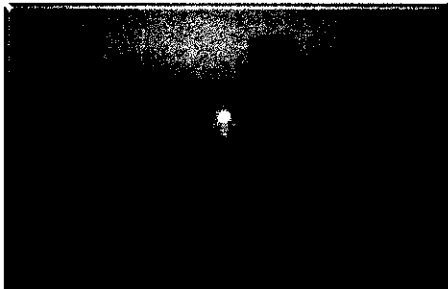


fig. 027

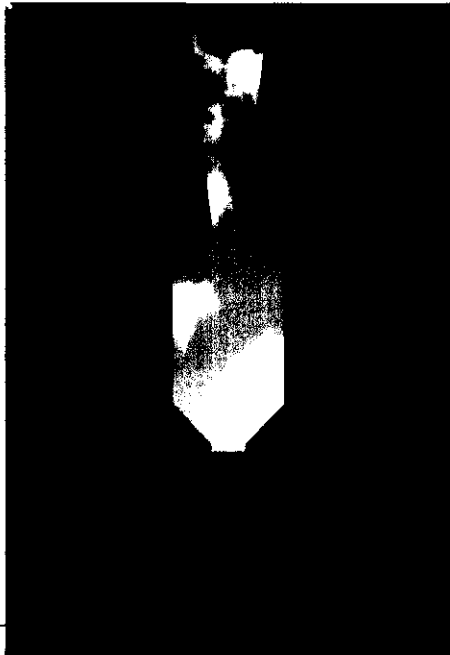
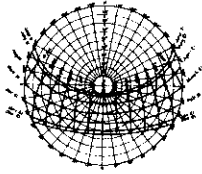


fig. 030



fig. 028

psycholotecture...



description: surface reflection-frontal/overhead

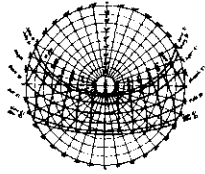
features: frontal planes are spaced apart to create openings.
interior reflection surfaces are mirrored.
secondary opening cut in ceiling perpendicular to main one.

test results: spring months (march 15 used as average analysis date)
early morning produced general indirect light from frontal entry. several long beams of light on floor and up walls from eastern perp. opening.
noon (including one hour pre/post) frontal opening producing large pattern of light onto wall which moved down to floor and back up other wall.
afternoon became the same as early morning but through western perp.
night (artificial lighting) floor lighting reflecting off of reflection panels to illuminate center portion of the space.

test results: summer months (June 21 used as average analysis date)
early morning produced general indirect light from frontal entry. several long beams of light on floor and up walls from eastern perp. opening.
noon (including one hour pre/post) frontal opening producing large pattern of light onto wall which moved down to floor and back up other wall. continued up wall until reflected from ceiling back onto floor.
afternoon became the same as early morning but through western perp.
night (same in every scenario).

test results: autumn months (september 15 used as average analysis date)
the general character of all times was nearly identical to the spring study.

test results: winter months (december 15 used as average analysis date)
early morning produced general indirect light from frontal entry. several long beams of light on floor and up walls from eastern perp. opening.
noon (including one hour pre/post) frontal opening producing large pattern of light onto wall which moved down to floor and back up other wall.
afternoon became the same as early morning but through western perp.
night (same in every scenario).



The use of natural light as a form giver has been around for centuries. historical precedents can be found down a number of avenues, including that of frank lloyd wright. using the sun as the driving design idea, structures such as the marting house in akron, ohio and the house for herbert in middleton wisconsin were created.

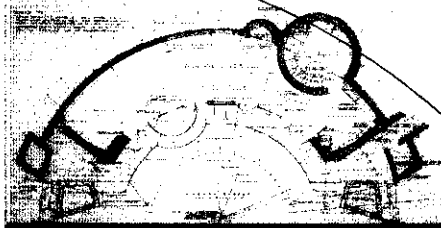


fig. 033

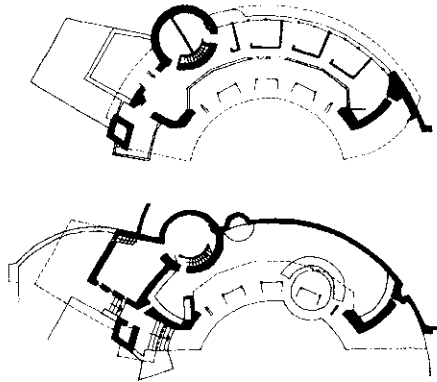


fig. 031



fig. 034

There is an overall general character of the arizona landscape, from barren desert to richly vegetated mountains. a notion of what is inherantly "arizona" remains.



fig. 032

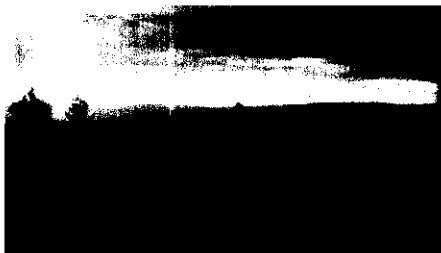


fig. 035

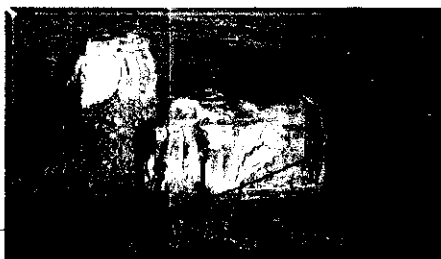
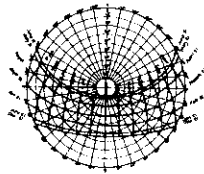


fig. 036

HISTORICAL
AND
PHYSICAL
CONTEXT



Location plays a vital role in any project based on the overall integration of natural light. when other factors such as building type and precedent are included in the equation, the location becomes the main focus of the design. in order for any design ideal which is based on the need for natural light to perform their functions, the key being the act of healing, object placement and location become critical. with such a specific goal in mind, the location of such an object becomes a focused and simple task.



fig. 037

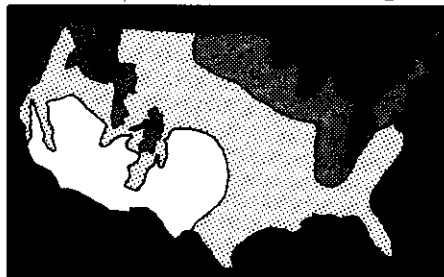


fig. 038

Global annual percentage of possible sunlight becomes the starting point for site selection. this search reveals northern africa and the southwest united states to have the highest amounts. eliminating africa, the southwest of the united states becomes the focus. further refinement reduces the selection to arizona. yet another distillation brings the final site location to southwest arizona, just south of the rainbow valley.

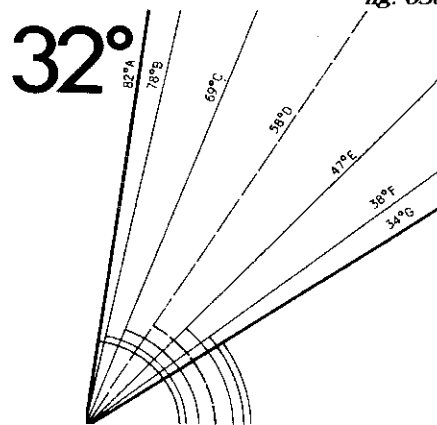


fig. 039

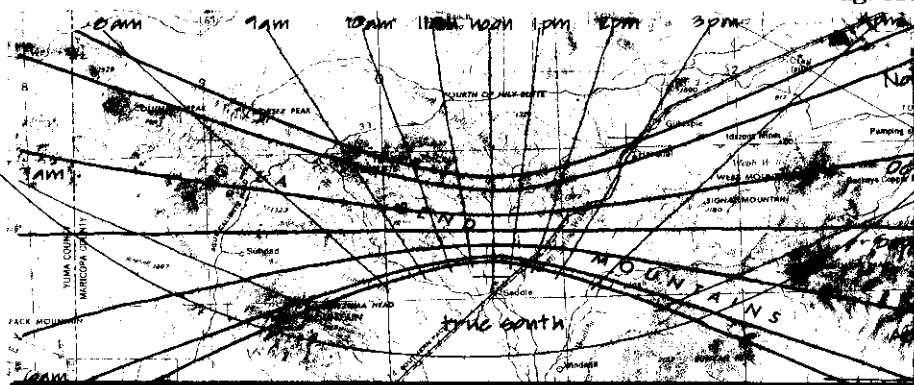


fig. 040

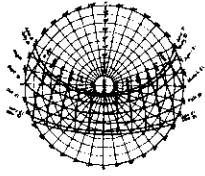


fig. 041

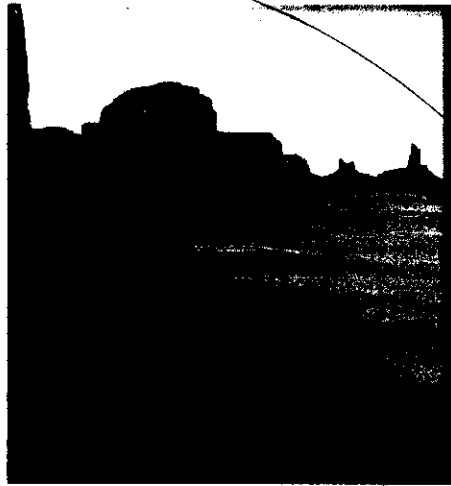


fig. 042



fig. 043



fig. 044

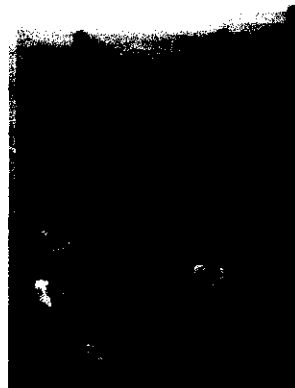


fig. 045



fig. 046

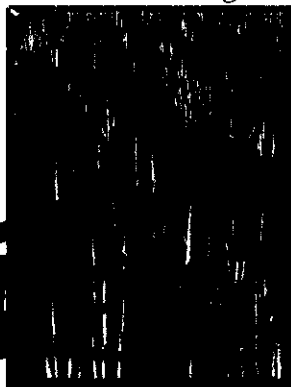


fig. 047



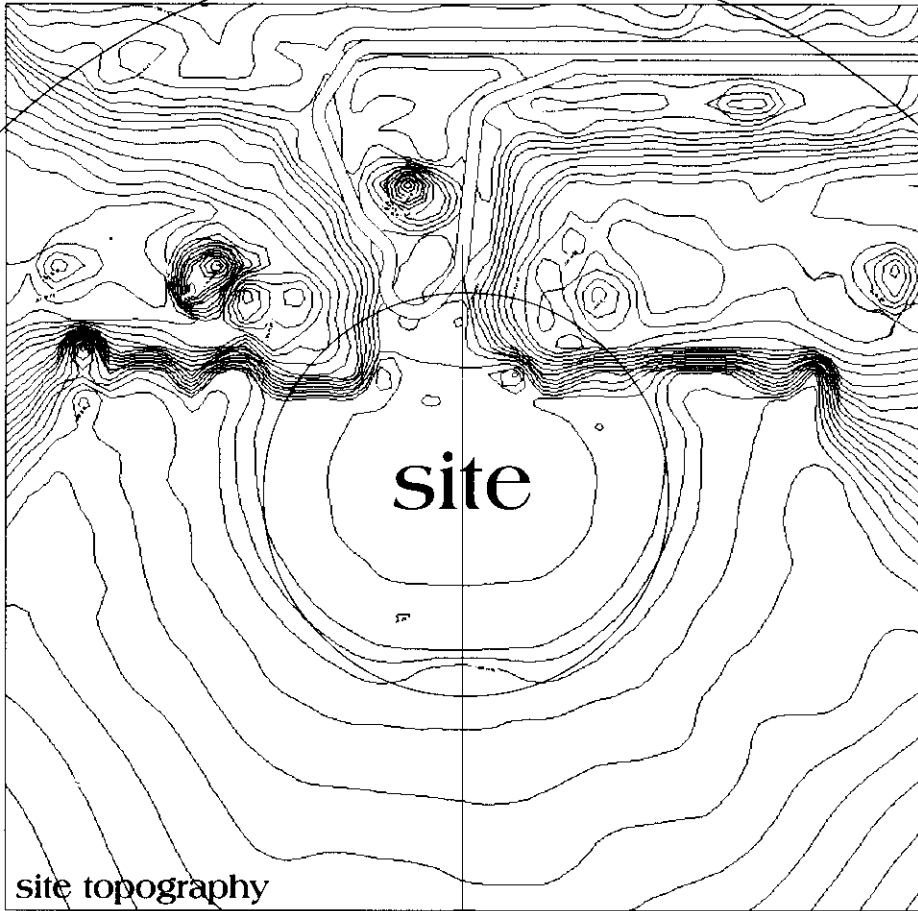
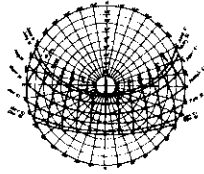
fig. 048

SITE REPORT

psycholotecture...

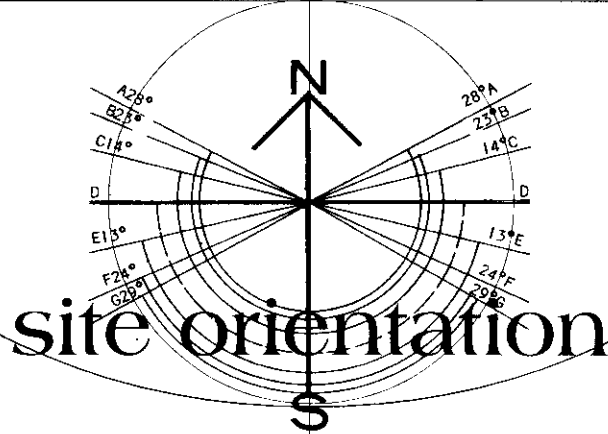


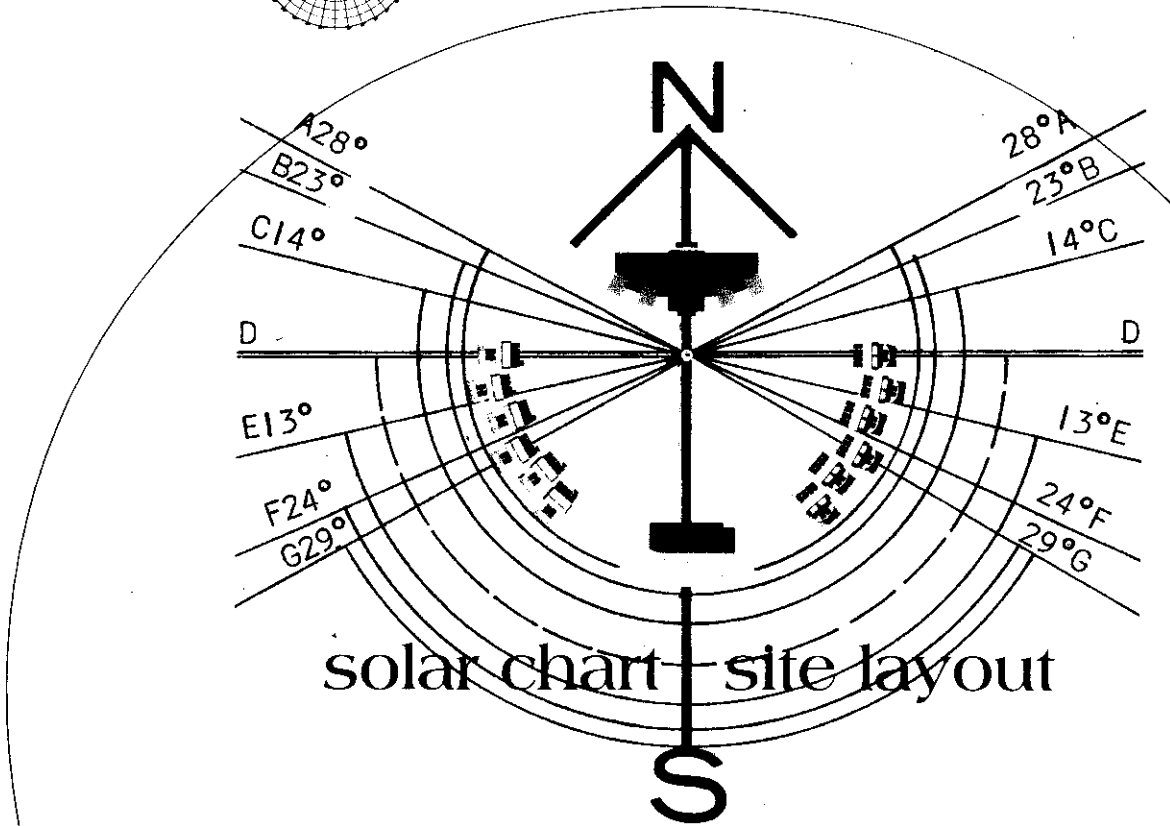
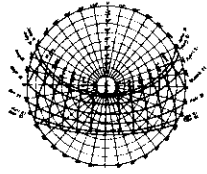
fig. 049



site topography

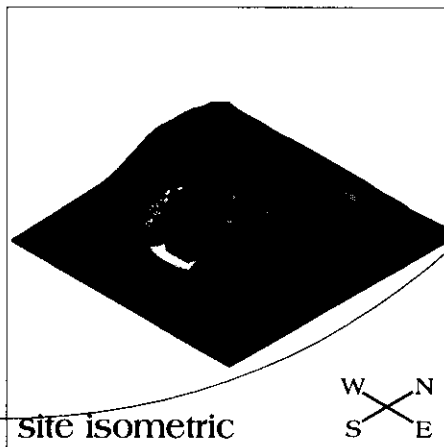
fig. 050





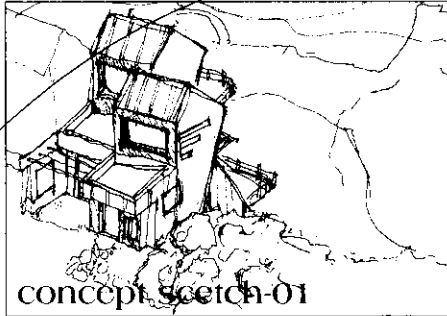
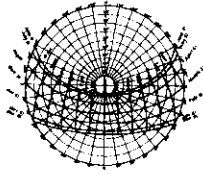
site plan

fig. 051



site isometric

fig. 052



concept sketch-01

fig. 053



concept sketch-02

fig. 054



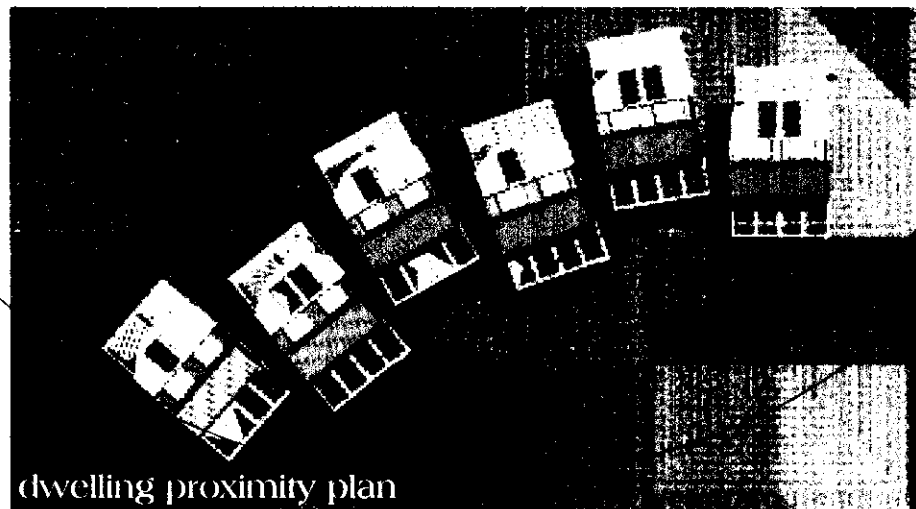
dwelling iso

fig. 055



dwelling iso

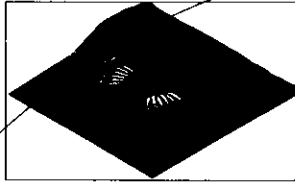
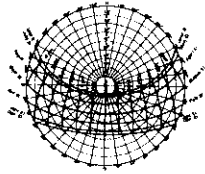
fig. 056



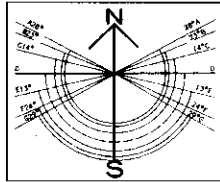
dwelling proximity plan

fig. 057

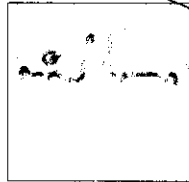
DESIGN
DEVELOPMENT



site isometric



orientation



topography

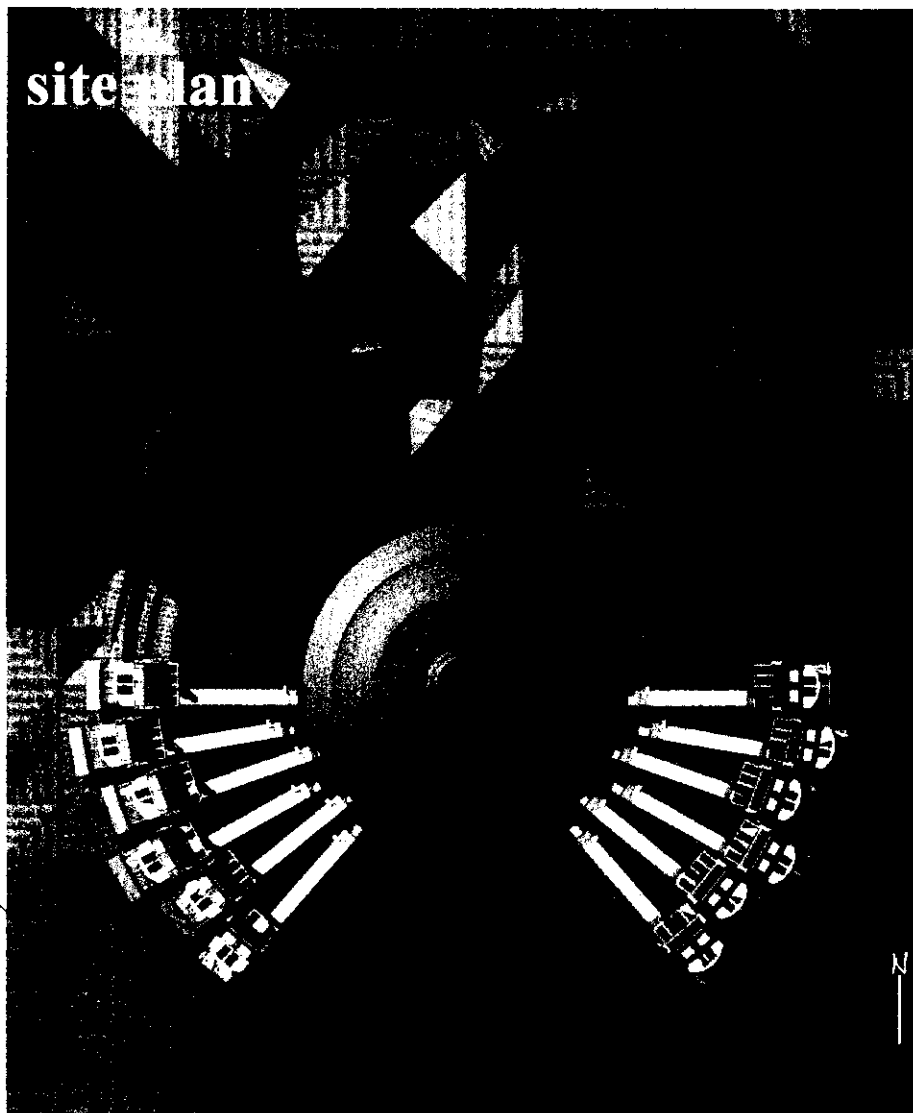
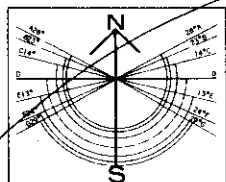
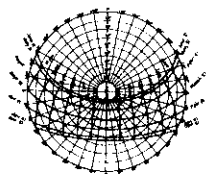


fig. 058



orientation



fig. 059

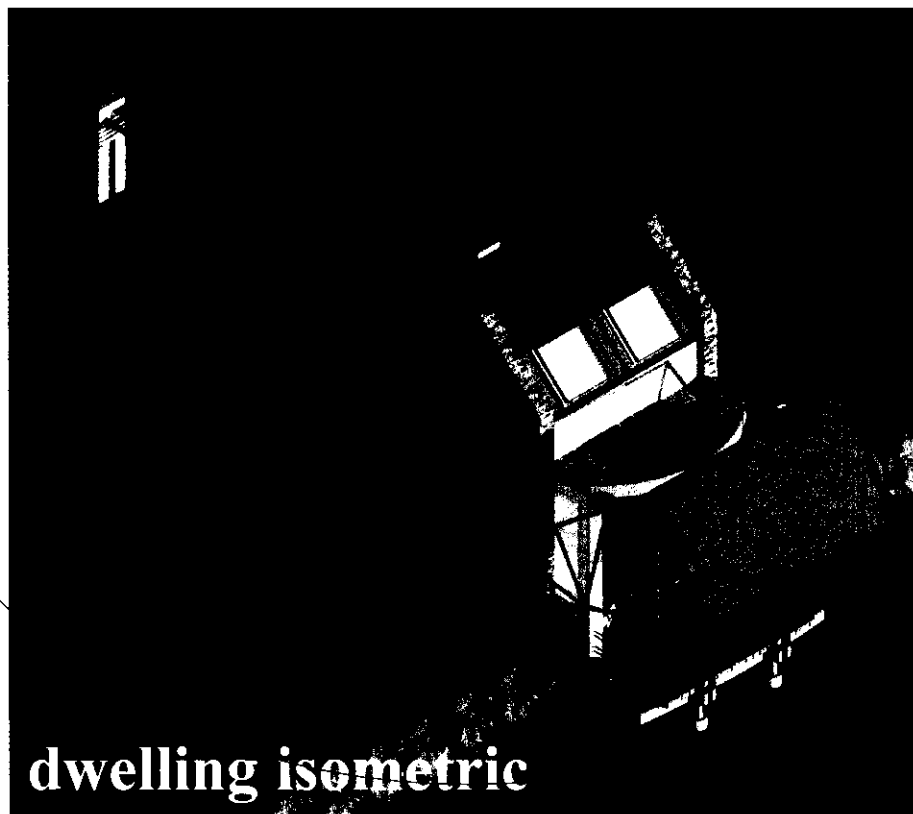
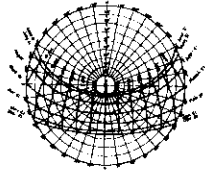
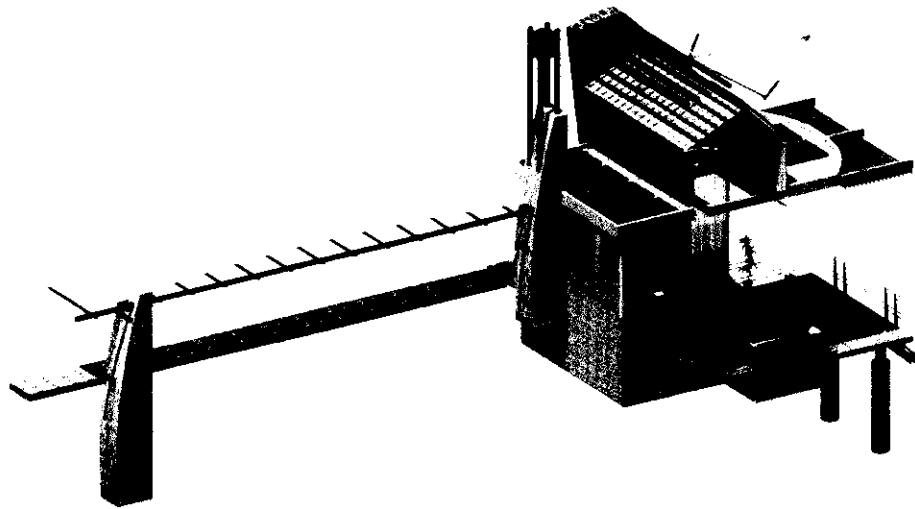


fig. 060



section/isometric [west/east]



building section [west/east]

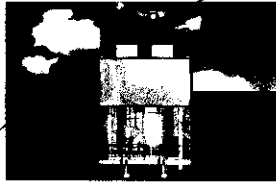
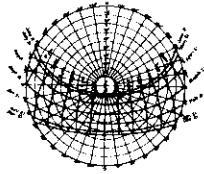
fig. 061



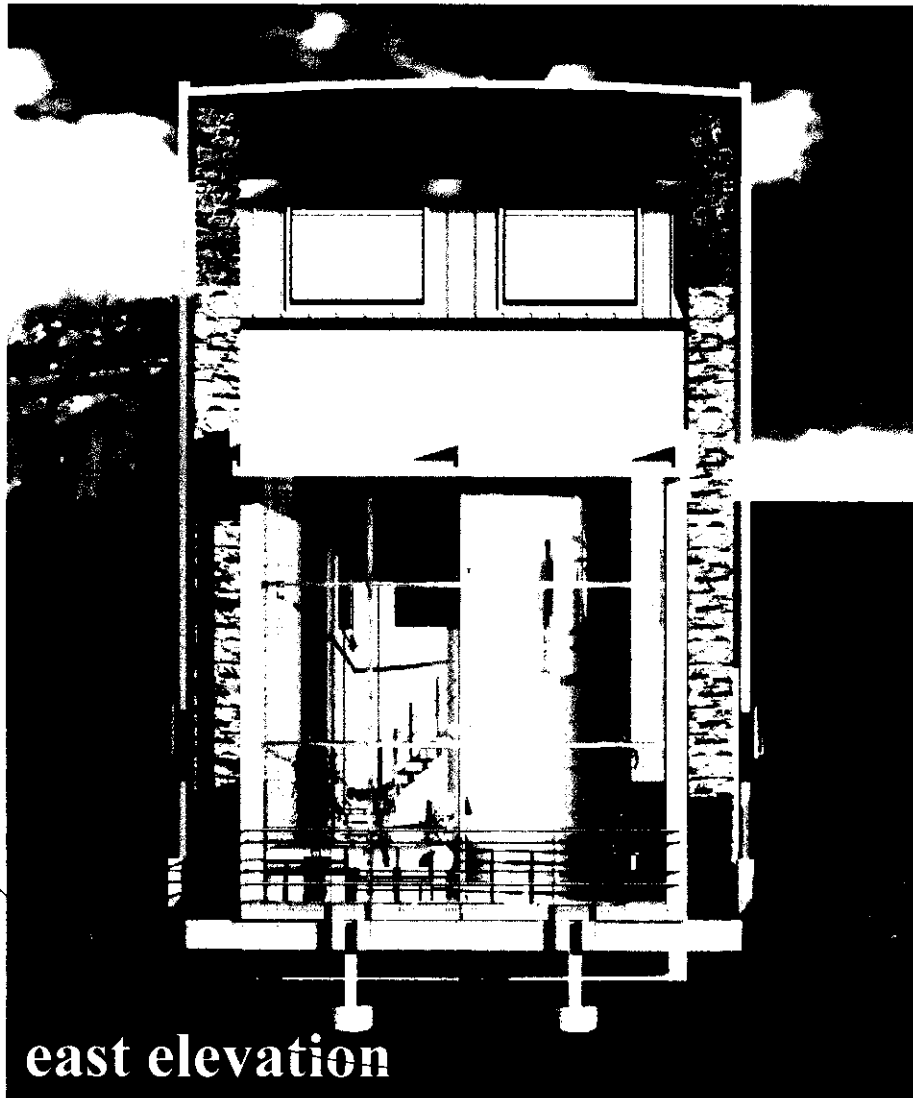
fig. 062

psycholotecture...

FINAL
DESIGN
SOLUTION



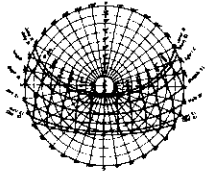
solar shade down



east elevation

fig. 063

FINAL
DESIGN
SOLUTION



solar shade tracking



fig. 064



fig. 065

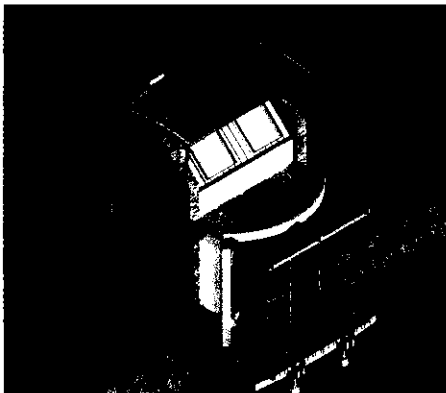
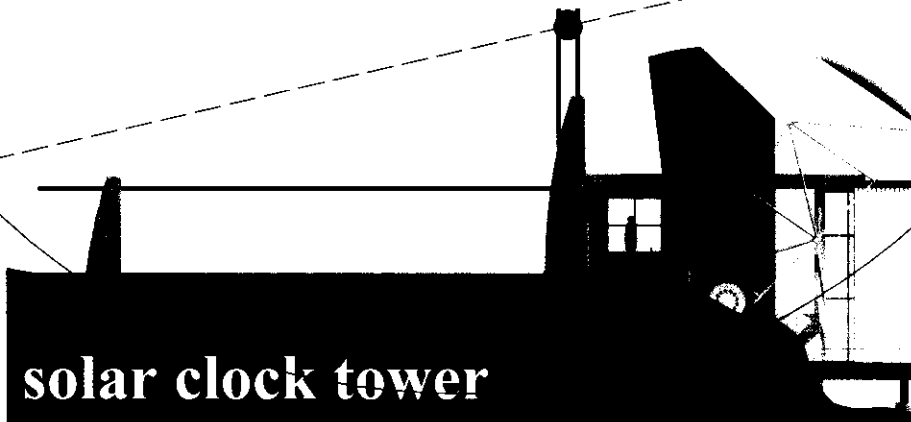


fig. 066

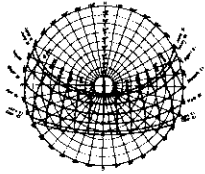


fig. 067



solar clock tower

fig. 068



a.m. dwelling solar entry

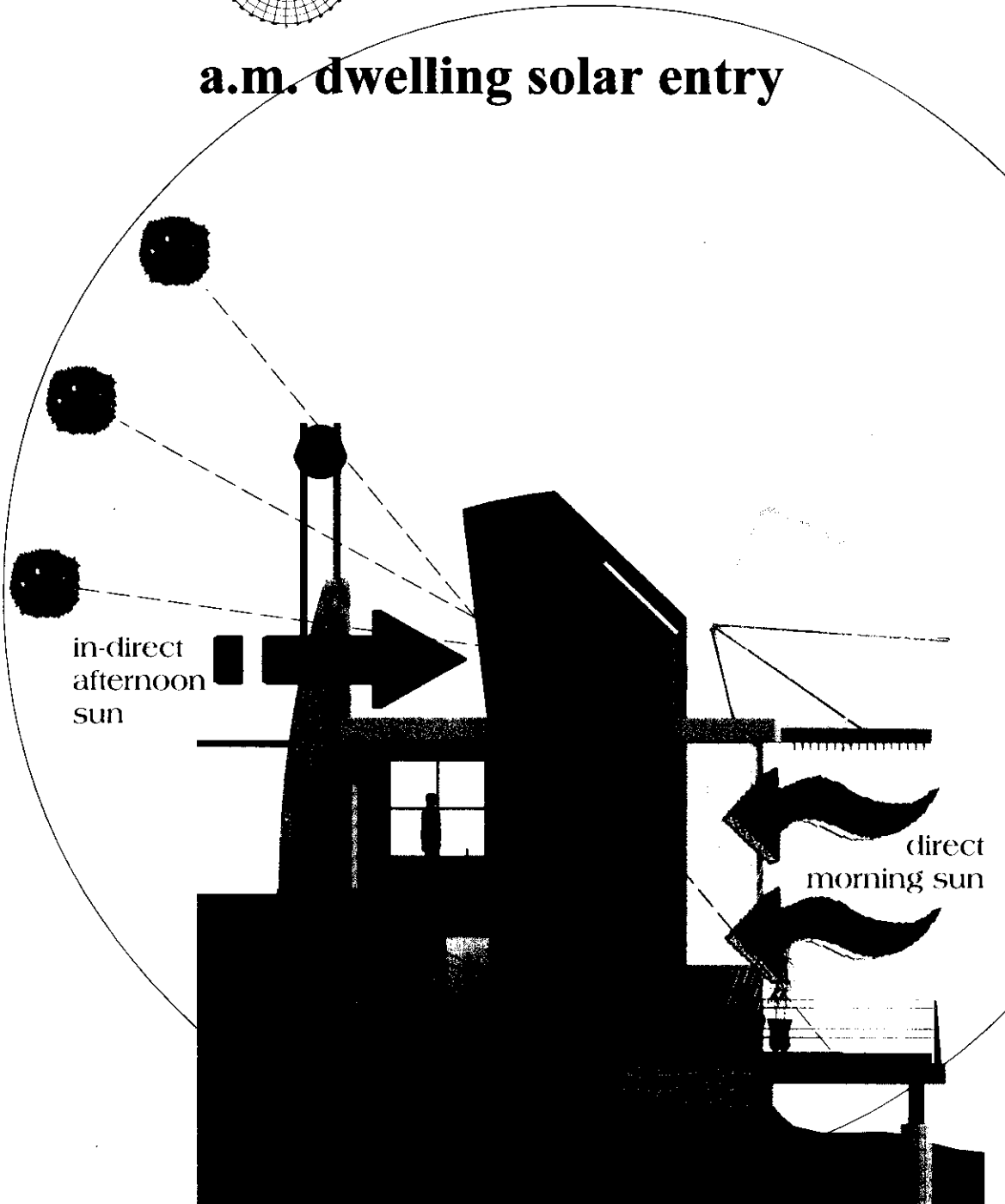
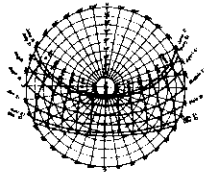


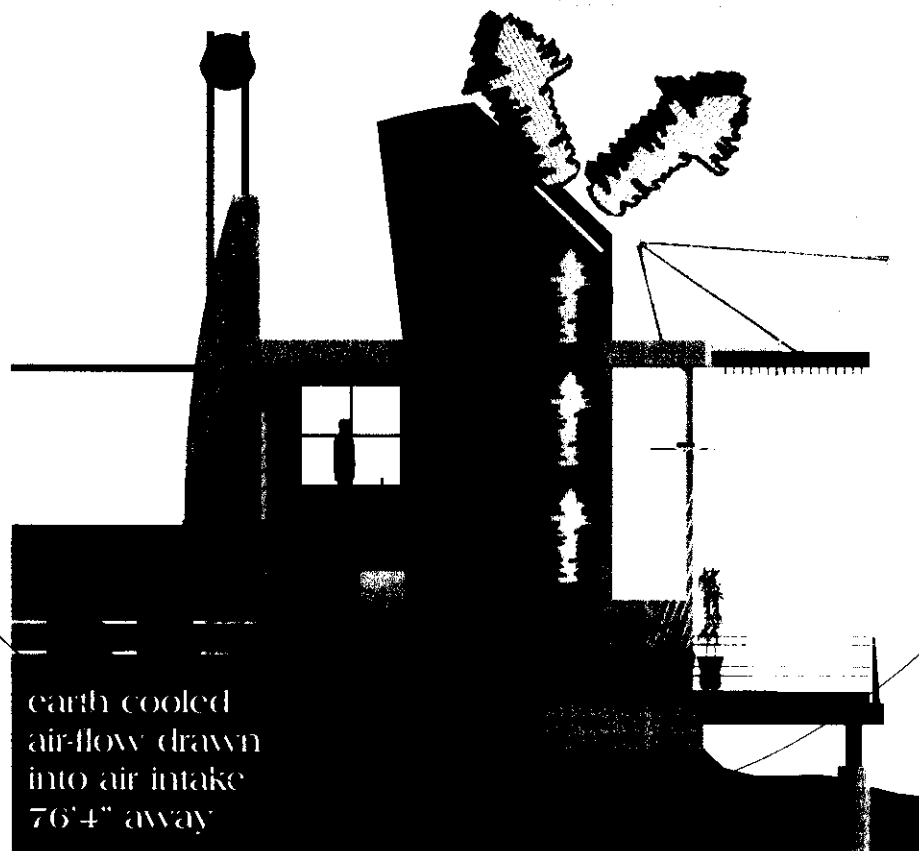
fig. 069

psycholotecture...

FINAL
DESIGN
SOLUTION



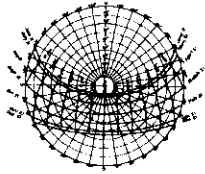
dwelling cooling system



earth cooled
air-flow drawn
into air intake
76'4" away

fig. 070

FINAL
DESIGN
SOLUTION



solar study-01

- 1
- 2
- 03
- 4
- 5
- 6
- 7
- 8
- 9
- 10
- 11
- 12

march 02, 1998 9:45am



solar shade up

fig. 071

march 02, 1998 9:45am



solar shade down

fig. 072

march 02, 1998 1:30pm



solar shade up

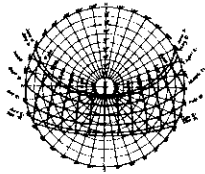
fig. 073

march 02, 1998 1:30pm



solar shade down

fig. 074



solar study-02

- 1
- 2
- 3
- 4
- 5
- 06
- 7
- 8
- 9
- 10
- 11
- 12

june 02, 1998 9:45am



solar shade up

fig. 075

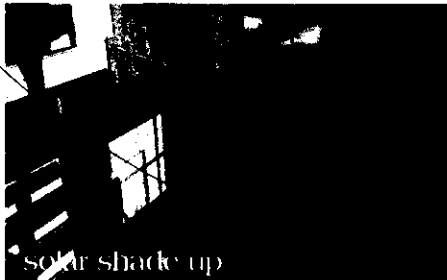
june 02, 1998 9:45am



solar shade down

fig. 076

june 02, 1998 1:30pm



solar shade up

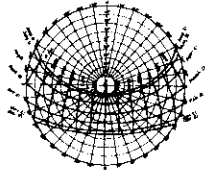
fig. 077

june 02, 1998 1:30pm



solar shade down

fig. 078



solar study-03

1

2

3

4

5

6

7

8

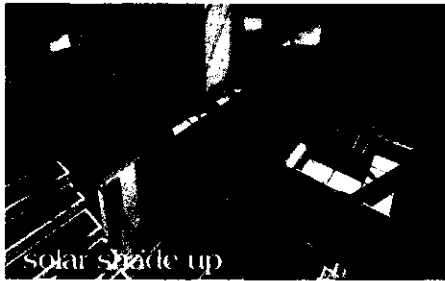
09

10

11

12

sept. 02, 1998 9:45am



solar shade up

fig. 079

sept. 02, 1998 9:45am



solar shade down

fig. 080

sept. 02, 1998 1:30pm



solar shade up

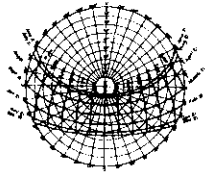
fig. 081

sept. 02, 1998 1:30pm



solar shade down

fig. 082



solar study-04

- 1
- 2
- 3
- 4
- 5
- 6
- 7
- 8
- 9
- 10
- 11
- 12

dec. 02, 1998 9:45am



solar shade up

fig. 083

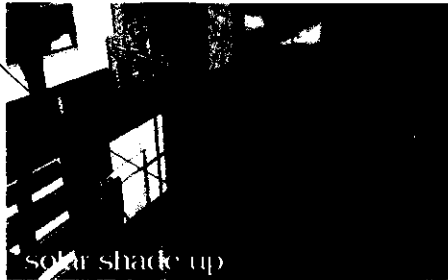
dec. 02, 1998 9:45am



solar shade down

fig. 084

dec. 02, 1998 1:30pm



solar shade up

fig. 085

dec. 02, 1998 1:30pm



solar shade down

fig. 086

FINAL DESIGN
SOLAR STUDIES

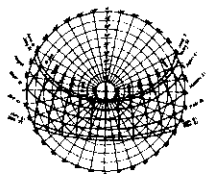


fig. 087

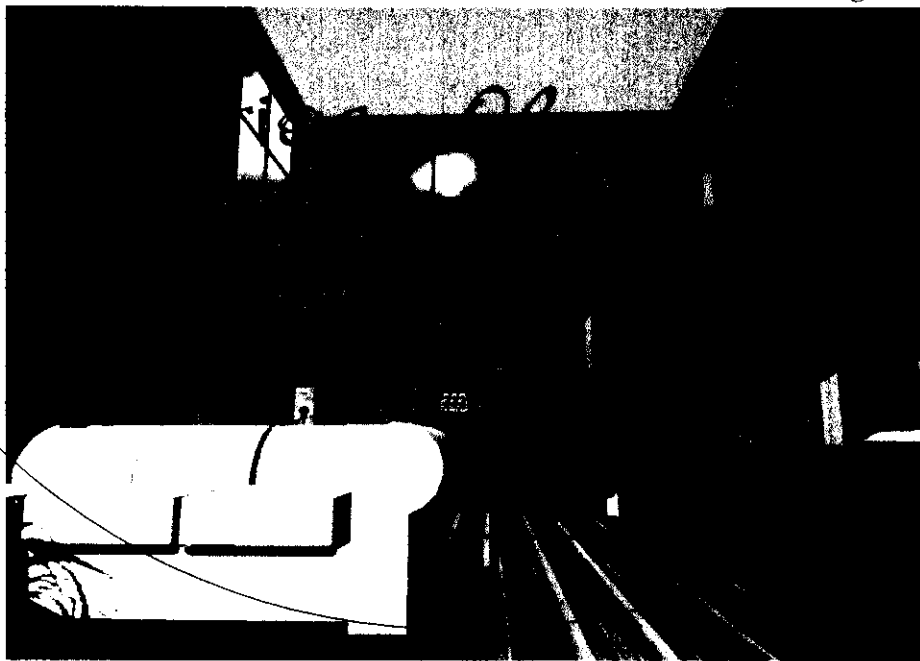


fig. 088

psycholotecture...

FINAL
DESIGN
INTERIORS

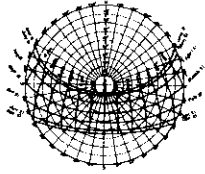


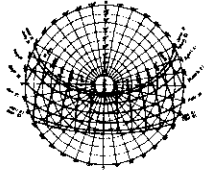
fig. 089



fig. 090

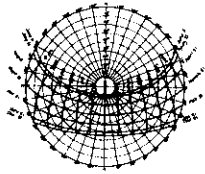
psycholotecture...

FINAL
DESIGN
INTERIORS



- fig:**
- .001 (over) sun ray with probes
 - .002 sky-01
 - .003 sky-02
 - .004 sky-03 (inv)
 - .005 sky-04 (opposite)
 - .006 solar explosion-01
 - .007 infrared view of male skull
 - .008 study model-01
 - .009 study model-02
 - .010 study model-03
 - .011 orthographic sun diagram-01
 - .012 orthographic sun diagram-02
 - .013 prelim 3-d model (s.s.#1)-1
 - .014 prelim 3-d model (s.s.#1)-2
 - .015 prelim 3-d model (s.s.#1)-3
 - .016 prelim 3-d model (s.s.#1)-4
 - .017 prelim 3-d model (s.s.#1)-5
 - .018 prelim 3-d model (s.s.#1)-6
 - .019 prelim 3-d model (s.s.#2)-1
 - .020 prelim 3-d model (s.s.#2)-2
 - .021 prelim 3-d model (s.s.#2)-3
 - .022 prelim 3-d model (s.s.#2)-4
 - .023 prelim 3-d model (s.s.#2)-5
 - .024 prelim 3-d model (s.s.#2)-6
 - .025 prelim 3-d model (s.s.#3)-1
 - .026 prelim 3-d model (s.s.#3)-2
 - .027 prelim 3-d model (s.s.#3)-3
 - .028 prelim 3-d model (s.s.#3)-4
 - .029 prelim 3-d model (s.s.#3)-5
 - .030 prelim 3-d model (s.s.#3)-6
 - .031 maring house
 - .032 arizona landscape-01
 - .033 house for herbert-01
 - .034 house for herbert-02
 - .035 arizona landscape-02
 - .036 arizona landscape-03
 - .037 global isoflux contours
 - .038 national sunlight levels
 - .039 sun angle diagram
 - .040 sun position chart/site map
 - .041 arizona landscape-04
 - .042 arizona landscape-05
 - .043 arizona landscape-06
 - .044 arizona landscape-07
 - .045 arizona landscape-08
 - .046 arizona landscape-09
 - .047 arizona landscape-10
 - .048 arizona landscape-11
 - .049 site map-01 & 02
 - .050 archi-site topography
 - .051 archi-site topography
 - .052 3-d model-01
 - .053 3-d model-02
 - .054 3-d model-03
 - .055 3-d model-04
 - .056 3-d model-05
 - .057 3-d model-06
 - .058 3-d model-07
 - .059 3-d model-08
 - .060 3-d model-09
 - .061 3-d model-10
 - .062 3-d model-11
 - .063 3-d model-12
 - .064 3-d model-13
 - .065 3-d model-14
 - .066 3-d model-15
 - .067 3-d model-16
 - .068 3-d model-17
 - .069 3-d model (s.s.#1)-1 march
 - .070 3-d model (s.s.#1)-2 march
 - .071 3-d model (s.s.#1)-3 march
 - .072 3-d model (s.s.#1)-4 march
 - .073 3-d model (s.s.#2)-1 june
 - .074 3-d model (s.s.#2)-2 june
 - .075 3-d model (s.s.#2)-3 june
 - .076 3-d model (s.s.#2)-4 june
 - .077 3-d model (s.s.#3)-1 sept
 - .078 3-d model (s.s.#3)-2 sept
 - .079 3-d model (s.s.#3)-3 sept
 - .080 3-d model (s.s.#3)-4 sept
 - .081 3-d model (s.s.#4)-1 dec
 - .082 3-d model (s.s.#4)-2 dec
 - .083 3-d model (s.s.#4)-3 dec
 - .084 3-d model (s.s.#4)-4 dec
 - .085 3-d model interior-01
 - .086 3-d model interior-02
 - .087 3-d model interior-03
 - .088 3-d model interior-04
 - .089 map of human brain patterns
 - .090 sky-05
 - .091 thesis review photograph-01
 - .092 thesis review photograph-02
 - .093 (left icon) sun tracking chart
 - .094 (icon bar) solar explosion-02

fig. 091



David, John and Anthony D. Lewis
University Press, 1982.

Brown, G Z
1985

Psychology for Architects.

Architectural Common Sense, Sun, Princeton, NJ
1983

Good, Lawrence, and et al.
1965
Illinois: Thomas

Hyman, Jane Wegscheider
New York: St
Martins Press, 1990.

Institute for Mining and Minerals Research (IMMR)
Kentucky
1984.

Keyes, John
1975.
New York: Morgan and Morgan

Küller, Rikard.
Studentlitteratur, 1975

Lakeman, Sandra D.
Luis Obispo: Natural Light Books, 1992.
San

Lam, William M.
New
York: Reinhold, 1986.

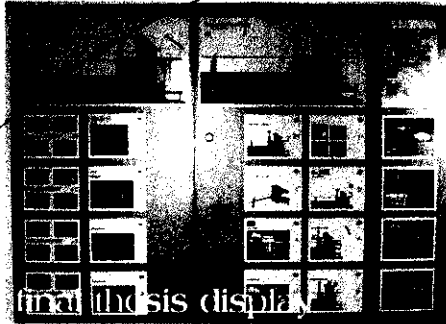
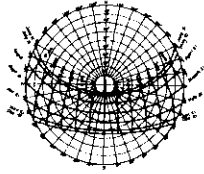
Lambeth, James.
Private, 1977.

Lynes, J.A.
1968.
Amsterdam: Elsevier.

Moller, Clifton B.
New York: Horizon Press, 1968

Old, John N.
John Old Properties, Inc. 1973
Old Greenwich, Ct

fig. 092



final thesis display

fig. 093

ed.u.ca.tion \ej-ə-'kā-shən\ n 1: the action or process of educating or being educated 2: a field of knowledge dealing with technical aspects of teaching.



final thesis display

fig. 094

Andy Seager
studio instructor

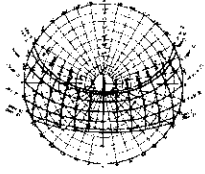
Patrick George
thesis critic

Eric Nay
consultant

Jeff Culp
consultant

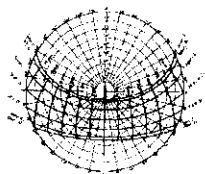
Since the beginning of the thesis year many people have come along whose devotion to the field of architecture, and to the education of young architects, has helped and inspired me throughout my educational process. without all of their knowledge, wisdom, understanding, influence, and sharing of experiences, this architectural thesis would not have been even remotely possible.

thank you all



n o t e s

psycholotecture . . .



n o t e s

psycholotecture...