

ECHOES OF AN ANCIENT PAST

HOUSING FOR THE ZINACANTAN MAYA

THESIS 1988

RUSSELL D. LEWIS

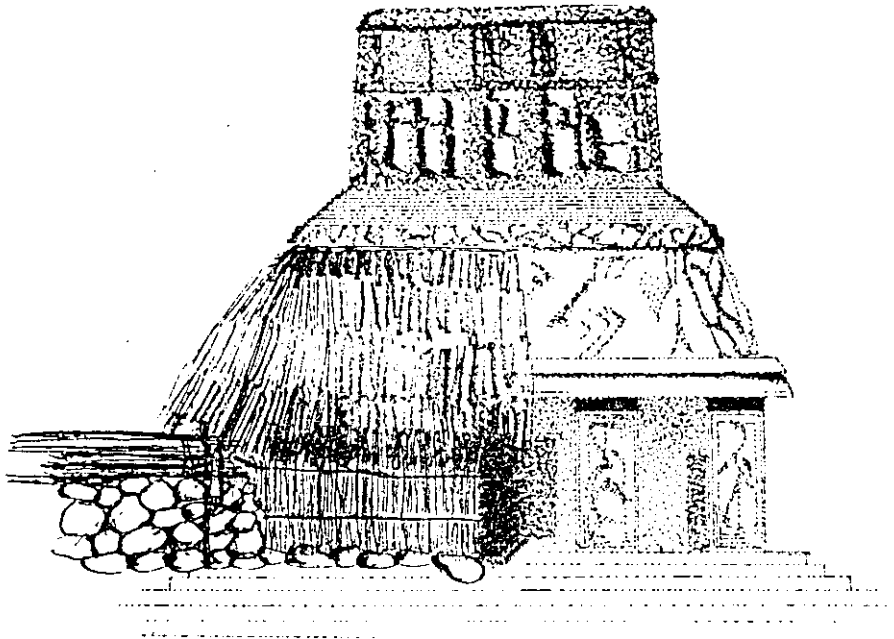

BALL STATE UNIVERSITY
COLLEGE OF ARCHITECTURE AND PLANNING

This Thesis document is submitted in partial fulfillment of the course requirements for Architectural Thesis Arch 406 and the requirements for the degree: Bachelor of Architecture.

Building type: Housing

Location of project: The Municipality of Zinacantan Chiapas, Mexico

Thesis Committee Chair: Alfredo Missair

Thesis Committee Member: J.A. Chewing

Consultant: Donald Cochran

Copyright 1988 by Russell D. Lewis and Ball State University
College of Architecture and Planning. 36 pages

All rights reserved. No part of this work covered by the copyright hereon may be reproduced or used in any form or by any means- graphic, electronic, or mechanical, including photocopying, recording, taping, or information storage and retrieval systems- without permission of the author or the publisher.

Published by the College of Architecture and Planning,
Ball State University
Muncie, Indiana 47306

Long have we sought to be inspired
by ancient Greek and Roman art-the heritage
of europe.

All unaware that buried deep in the dark
jungles of our southern lands there lies
vestiges of a half forgotten race, a race that
ran its course and died-a race inspired by
mighty Kukulcan to build the noble temples
of Copan-Mother City of the Mayas.

But art etrnal never dies.

So in the rebirth of this wondrous
people new cities sprang forth to life-Chichen Itza
Uxmal, and Mayapan.

The embers of the dying fire were
fanned to life and art once more flamed
forth to their eternal glory.

Then death again did claim its toll, and once more
Maya art was dead.

Not dead but only slumbering to be awakened by
a young people to the north; their privilage it shall be
to take up the work were Maya left off, and carry on.

The second renaissance has just begun.

O! Great Kukulcan make clear to them their
heritage sublime and inspire them to nobler ideas
than Maya ever dreamed.

George Oakley Totten

This work is dedicated to Patricia Lewis and Clarissa Williams
without them I would not have strived for so much.

TABLE OF CONTENTS

ABSTRACT.....	1
ECHOES OF AN ANCIENT PAST	
INTRODUCTION.....	2
CHAPTER ONE-THE MAYAN HERITAGE.....	3
THE ARCHITECTURE OF THE MAYA	
MAYAN DOMESTIC ARCHITECTURE	
MAYAN CLASSICAL ARCHITECTURE	
PRELIMINARY CONCLUSIONS	
CHAPTER TWO-THE ZINACANTAN MAYA*.....	13
THE MINICIPALITY OF ZINACANTAN	
ZINACANTAN SOCIAL PATTERNS	
DOMESTIC ARCHITECTURE	
SUMMARY	
CHAPTER THREE-THE DESIGN SOLUTION.....	21
PHASE ONE MASTER PLAN	
PHASE TWO MASTER PLAN	
UNIT PROTOTYPE	
CONCLUSIONS.....	36

*All information concerning the Zinacantan Maya compiled from
Zinacantan: A Maya Community in the Highlands of Chiapas
Evon Z. vogt; Cambridge, Massachusetts, Havard university Press,1969.

Echoes of an Ancient Past

In order to produce quality architecture we must neither divest ourselves of the architectural past, nor use a tunnel vision of historic architecture. There are other viable sources of architectural tradition besides those of Europe which are most often focused upon. There exists throughout the world remnants of advanced cultures and surviving vernacular traditions which are potential wells of untapped knowledge. Within their own contexts they are a viable source of information and inspiration. The worlds classical cultures and vernacular traditions are based on centuries of trial and error experimentation. To ignore the results of this experimentation would add to the knowledge man has allowed to escape him over the centuries.

As the subject of my thesis I have focused upon one of the classical cultures of the so called new world, the Maya. There presently exists within Meso-America physical and socio-cultural remnants of the Mayan culture, including a timeless vernacular building tradition. There is a direct link between this vernacular tradition and the high style architecture of the Mayan classical period, which evolved from the vernacular tradition. It is possible that a contemporary housing form can be evolved from the present Mayan vernacular. This is an effort to improve upon the permanence and aesthetic quality of the existing vernacular architecture; and improve through the use of architecture the condition of life. As a test case I have chosen a rural Mayan community in Chiapas, Mexico and proposed designs for low technology single family dwellings.

INTRODUCTION

It is my belief that architecture as built form is based on past experience; and that we as architects must not limit ourselves in the search for viable solutions to architectural problems. I undertook this as a means of exploring an architectural heritage other than that of European tradition; and as an effort to examine how I as an architect could respond within socio-cultural parameters to an existing vernacular building tradition in order to improve the quality of life.

THE MAYAN HERITAGE

THE MAYAN HERITAGE

Historically indigenous forms of architecture have been largely overlooked leaving a vast untapped well of knowledge. The physical and cultural remnants of the Mayan civilization are a prime example of this unutilized experience. The Maya are by no means a lost people. They have resisted the destruction of their way of life by incorporating the compatible aspects of Spanish American civilization into their lifestyle. In fact the boundaries of today's maya speaking peoples fall within those of classical Mayan civilization. The Mayan Empire covered an 130,000 square mile area comparable to an area three fifths the size of France. This region located in Meso-America comprised all of Guatemala, except a low Pacific coastal strip, sections of western El Salvador, the western fringes of Honduras, Belize(formerly British Honduras), and in Mexico the states of Campeche, Tabasco, Yucatan, The Eastern half of Chiapas, and the Territory of Quintana Roo(Map 1). Within the context of the Mayan State this region is divided into Southern, Central, and Northern areas(Map 2).

Maya civilization had its beginnings in the Guatemalan highlands of the Southern Area. The earliest remnants of culture here

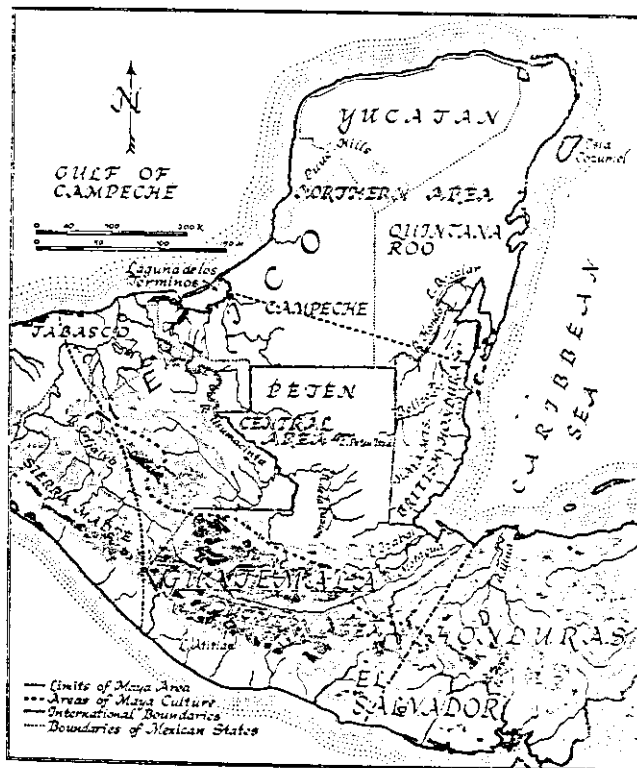

Map 1

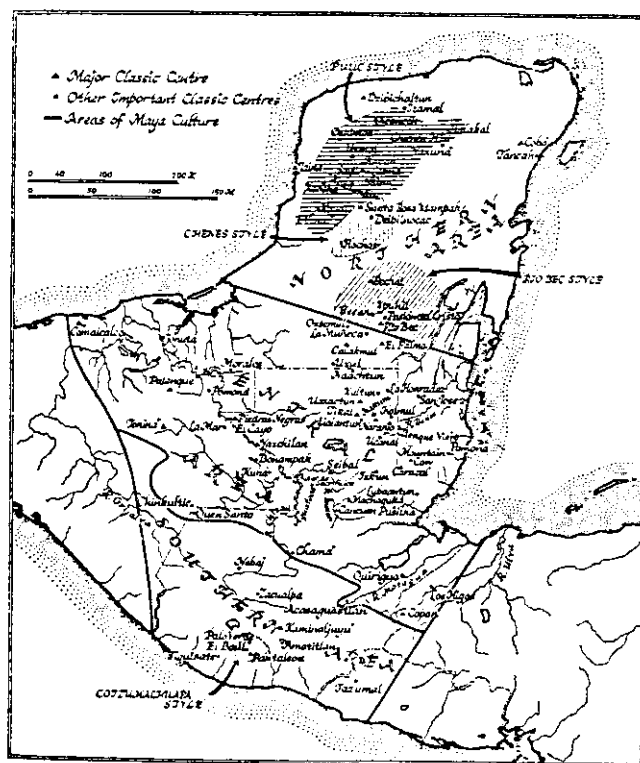

Map 2

date back to circa 1500 B.C. The Mayan culture formed in these highlands slowly spreading to the northeast (Table 1). Classic Mayan history has been divided into two periods, Old Empire 320 A.D. to 987 A.D., and New Empire 987 A.D. until 1697 A.D, the time of final spanish conquest (Rivet 1960). "...the word empire in these designations has no political meaning. It simply describes a homogeneous cultural ensemble, incorporating populations united by linguistics, artistic and social ties (Rivet 1960, p. 35)." The political organization was comparable to that of Greek city states, 6th to 2nd centuries B.C., and the Italian states of Venice, Florence, and Genoa, 8th to 15th centuries. The remnants of the Maya we now explore are the results of a highly developed social and cultural order.

CHRONOLOGICAL TABLE

DATES	PERIODS	SOUTHERN AREA		CENTRAL AREA	NORTHERN AREA
		Pacific Coast	Highlands		
1530	Late Post-Classic		Mixco Viejo	Tayasal	Independent States Mayapan
1200	Early Post-Classic	Tohil Plumbate	Ayampuc	(abandonment)	Toltec-Maya
900	Late Classic		Amatle-Pamplona	Tepeu	Puuc, Chenes
600	Early Classic	Cotzumalhuapa	Esperanza	Tzakol	Regional Styles Acanceh
300	Proto-Classic		Aurea Santa Clara	Matzanel	
150	Late Formative	El Baúl Crucero	Miraflores	Chicanel	Late Formative
300	Middle Formative	Conchas	Las Charcas	Mamom	Middle Formative
800	Early Formative	Cuadros Ocos	Arévalo	Xe	Mani Cenote
1500	(Archaic)				

Table 1

THE ARCHITECTURE OF THE MAYA

Aspects of classical mayan architecture evolved from their vernacular building traditions. Early Mayan temple architecture is the elevation of the common house form both literally and figuratively. Their can be no understanding of the Mayan architecture without knowledge of these two forms and their relationship to each other.

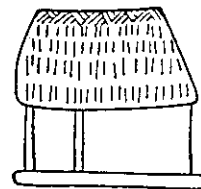

FIG 1

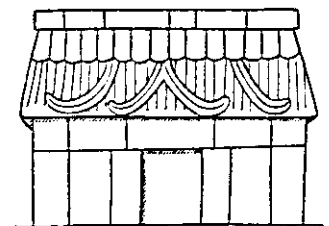

Fig 2

MAYAN DOMESTIC ARCHITECTURE

The vernacular building traditions of the Maya have remained unchanged for over 3500 years; and it is a combination of archeological evidence and the efforts of the modern Maya which gives us a true picture of mayan temporary architecture. The traditional Mayan house in rural areas is always given a discernable base in the form of a small platform or substructure. This feature is present regardless of the flatness of a site. There are two typical methods of construction for this substructure these are cut and/or fill. In the case of a cut base the surrounding ground is lowered leaving a platform with a relative height of 1 meter. if a porch or porticoes is present the platform extends beyond its boundaries(Fig 3). In the case of a fill base stone walls retain an earth and rubble infill; this is then packed and surfaced with marl([mixture of, lime, clay, and sand] Fig 4). Terraces are often added to one side of said platforms. More elaborate substructures may contain plastered porches, built in benches, or side walls. The bare earth of these platforms most often acts as the finished floor. There are instances were a marl mixture, known as "embutido", is used to provide a harder impervious surface. Examples of paved floors are rare, and consist of large rocks embeded in embutido. The Mayan house has four basic floor plans: apsidal, flattened ends, rectangular, and square(Fig 5). These plans are projected three dimensionally by a post and beam method of construction. The primary members of

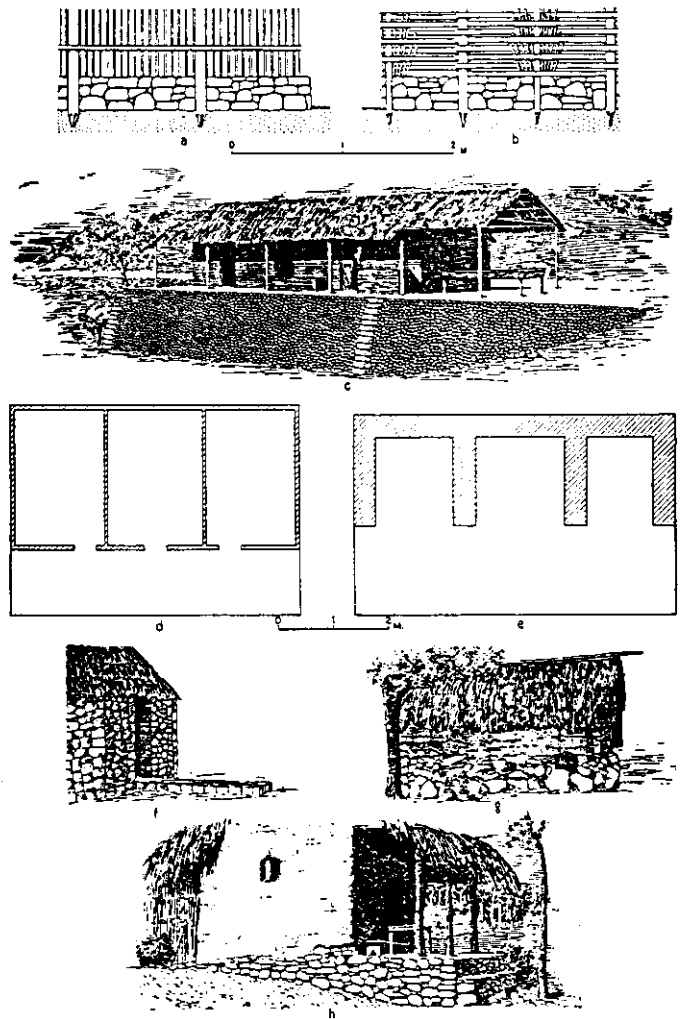

Fig 3

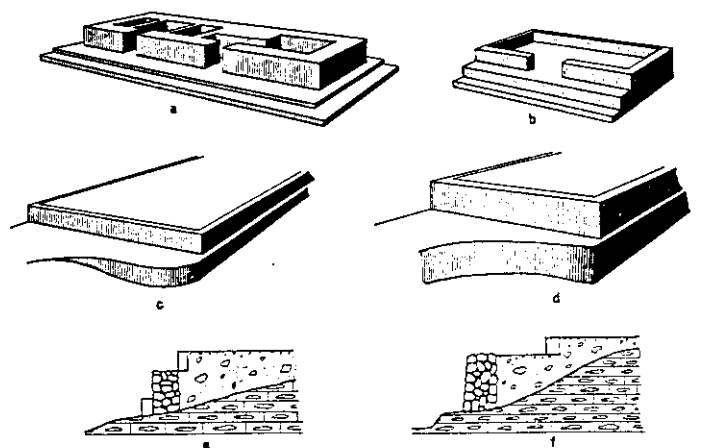

Fig 4

this system are mainposts(4 to 8 typical), transverse or crossbeams supported by the mainposts, and two or more transverse A-frames(Fig 6). There are instances where the ridgepole is carried by roof or kingposts. Regardless of its basic plan the mainposts of a house are set up in such a manner that they enclose a rectilinear space. The roof system is based on two types, the hip roof, and the gable roof. Pyramidal roofs exist as a form of the hip roof. Generally speaking the pitch of a Mayan roof falls somewhere between 42 to 60 degrees. All evidence suggests that roofing material is historically restricted to palm, grass, sugarcane, and corn blade thatch(Wauchope 1938).

Six basic types make up the vocabulary for wall construction:

VERTICAL POLES-poles set side by side in an upright position lashed together and braced by a horizontal stringer. The complete wall is sometimes daubed with mud(Fig 7).

HORIZONTAL AND VERTICAL WATTLE AND DAUB-interwoven poles and posts covered with mud.

DRY RUBBLE MASONRY-rock laid up without mortar displaying remarkable precision. Larger rocks are laid on end forming the lower course with smaller rock forming the upper courses of the wall(Fig 8).

RUBBLE MASONRY-building rock is set in

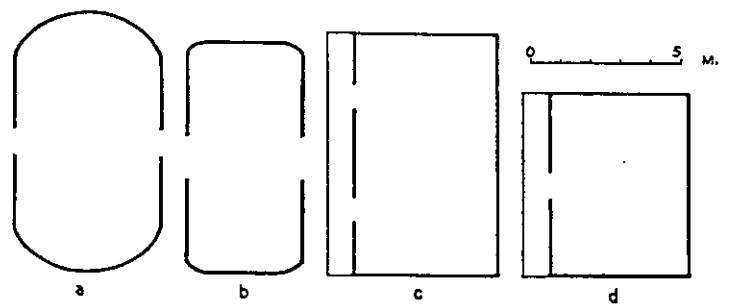

Fig 5

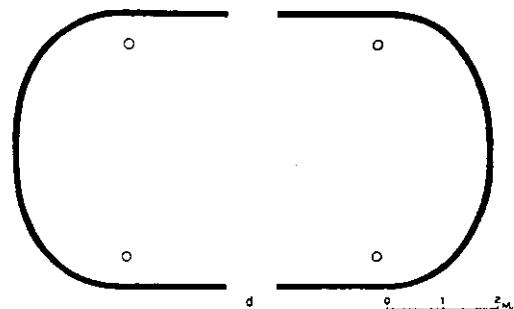
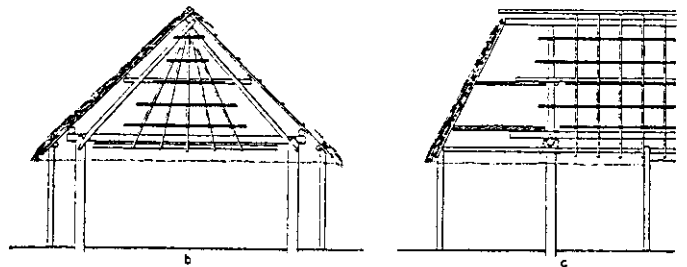
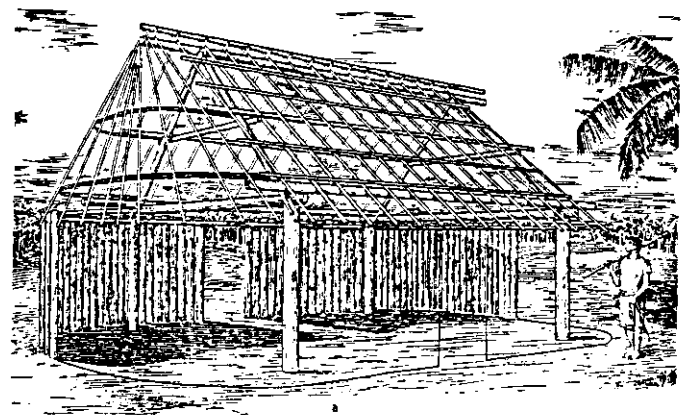

Fig 6

a limestone and marl mortar.

ADOBE BRICK-sun baked clay and mud bricks laid in the same manner as traditional masonry.

There is historical evidence of all the above types in use singularly and in various combinations(Wauchope 1938). These wall constructions enclose an area of roughly 49 sq meters(approx. 484 sq. ft.) with an exterior wall height of about 2.5 meters(approx. 8ft.). The character of the interior space is that of a single room with a high pitched ceiling. Divided mentally into separate rooms this area acts as the sleeping/living space(Fig 9). The majority of activity takes place outside the physical walls of the house, but not outside its area of dominance or influence. Much activity takes place on or around porticoes and porches. The building traditions of the mayan house are based in large on temporary materials, and therefore, exist as a temporary architectural form.

Mayan Classical Architecture

The temple and palace architecture of the Maya exists as their permanent architectural expression. This architectural form had its beginnings in the 2nd and 3rd centuries A.D. developing from the Mayan temporary architecture. At this point in time we see the emergence of the temple complexes, construction utilizing limestone on a large scale, plaster veneers, frontal stairways on pyramids, and elaborate

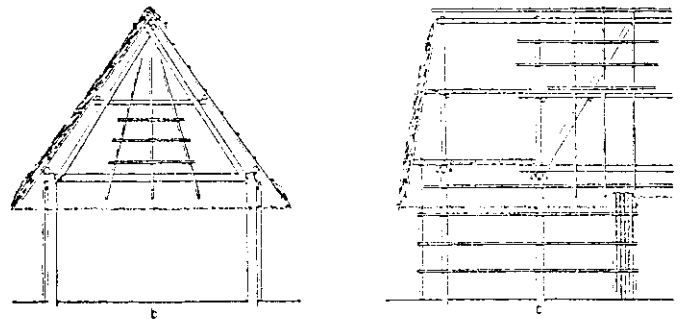
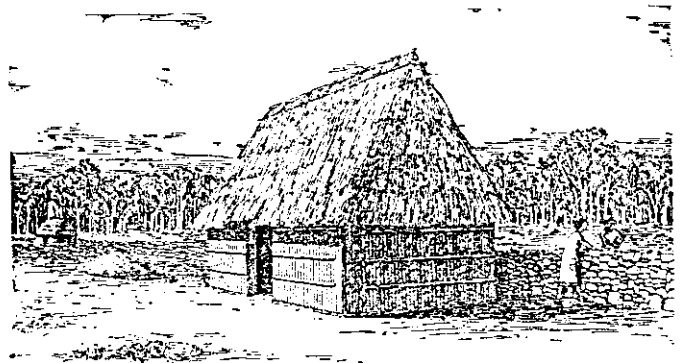

Fig 7

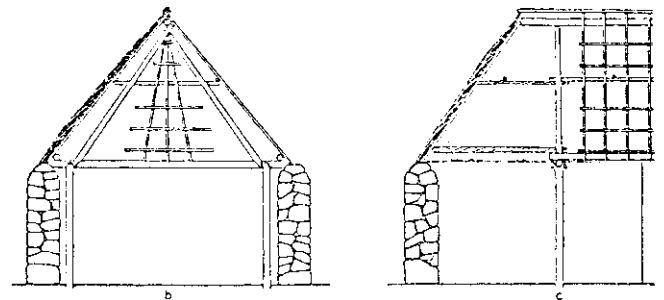
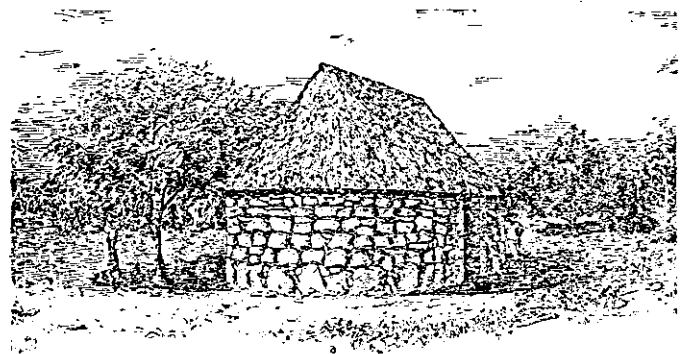

Fig 8

decorative frescoes. The Mayan classic style dates from 600 A.D. to approximately 1201 A.D. with the occupation of Chichen Itza: a primary center of Maya power, by the Toltecs, a people of non-mayan origins (Totten 1926, p. 27). As a style the Mayan classic period is denoted by the use of a fine limestone and/or rough stone faced with stucco as the primary building materials. Visually structures of this period are dominated by strong horizontal lines and the contrasts between plain surfaces and those manipulated to their fullest capacity (Fig 10).

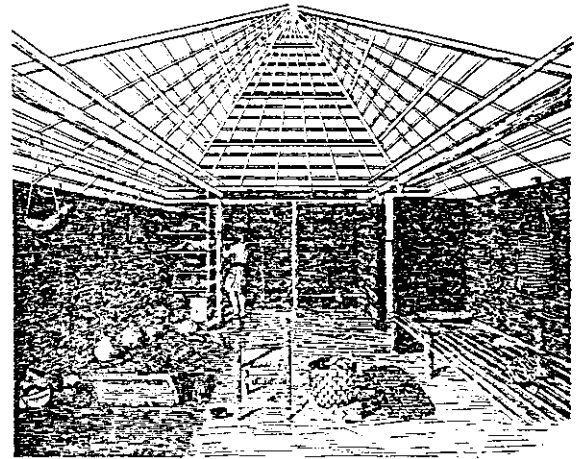
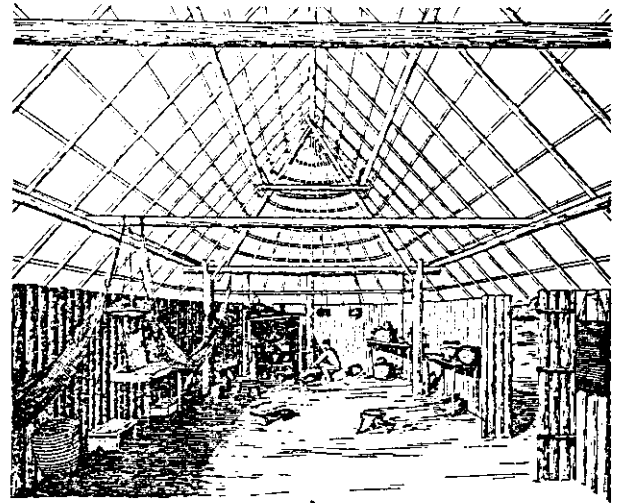
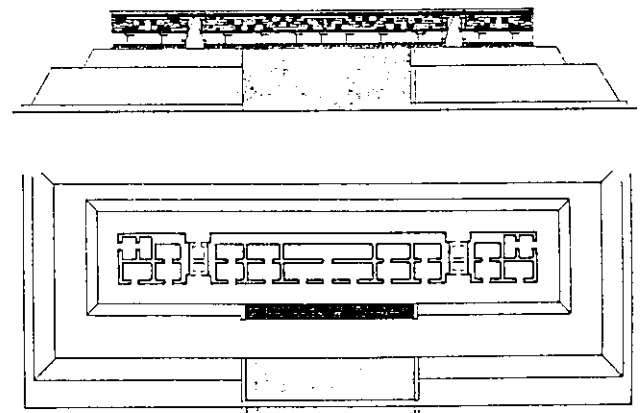

Fig 9



From Kubler, *Art and Architecture of Ancient America*, 2d ed.

House of the Governor Cross-section and Floor Plan

Fig 10a

The outer shells of this architecture are most often penetrated only on one face; in fact there is a strong frontal character to Mayan architecture in general. These penetrations, acting as doorways, gradually developed from small rectilinear openings into porticoes. Wall construction is not unlike that of the Romans. An inner and outer wall is built and the core then filled with the Mayan version of concrete. In some instances walls have been built of this material and then faced (Fig 11). Interior spaces, restricted by the methods of construction, have a maximum known width of 14ft (approx. 4m), but lengths of up to 100ft (approx. 30m) are not uncommon (Totten 1926, p 30).

Classic Maya architecture is characterized by several features that appear throughout the sphere of Mayan influence. These features are (Fig 12):

-A rubble or earthen filled substructure

- subdivided into terraced levels.
- One or more stairways leading from plaza spaces to the temples above.
- Corbeled vaults.
- Stucco veneers.
- Interior and exterior relief sculpture.
- Frontality in temple architecture.
- Restricted interior space
- Outward focused architecture that functioned as a stage for ritual activity.

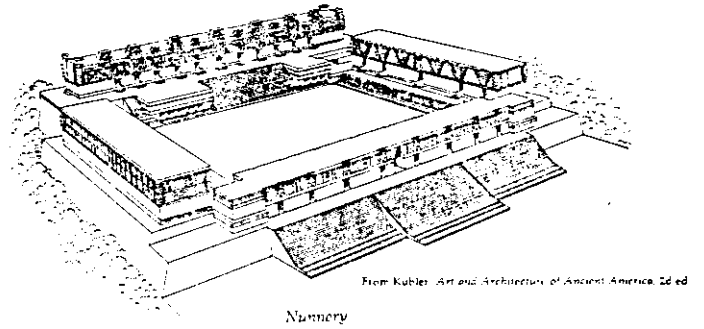
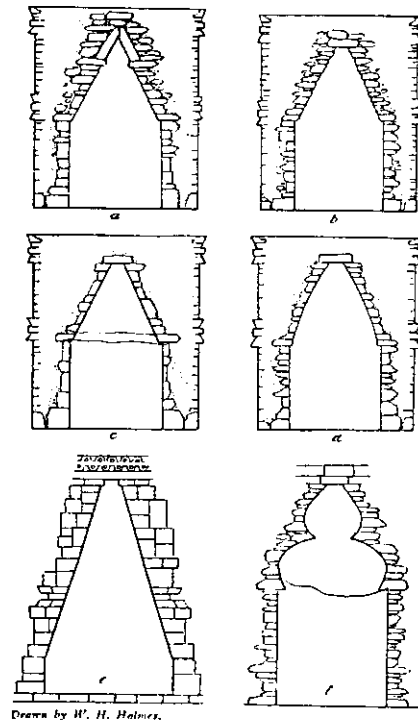

Fig 10b

One of the most striking of these features is the roof comb. Roof combs and/or the flying facade have a two fold origin. They exist as a decorative motif to increase height and as a means to stabilize top heavy construction. Visually the temple and roof comb make up one third of the total height of a pyramid.(Fig 13). A prime example of this one to three proportioning is the Temple of the Giant Jaguar(Temple I, Tikal)on the east side of the great plaza(Ferguson 1984). Structurally the roof comb and/or flying facade provides a similar function to that of the flying buttress in gothic architecture. one of the peculiarities of Mayan architecture is an unique variation on the corbeled arch that developed at Palenque. In most instances the outside walls of a vault are independently balanced, but this is not the case at Palenque. Here the two outer walls of vault lean against a center wall resulting in thinner bearing walls, which in turn create the possibility of a greater number of doors and a greater volume of interior space. Another peculiarity of Palenque is the so called Mansard effect in temple roof profiles. this is obtained by the



EXAMPLES OF MAYA ARCHES.

Fig 11

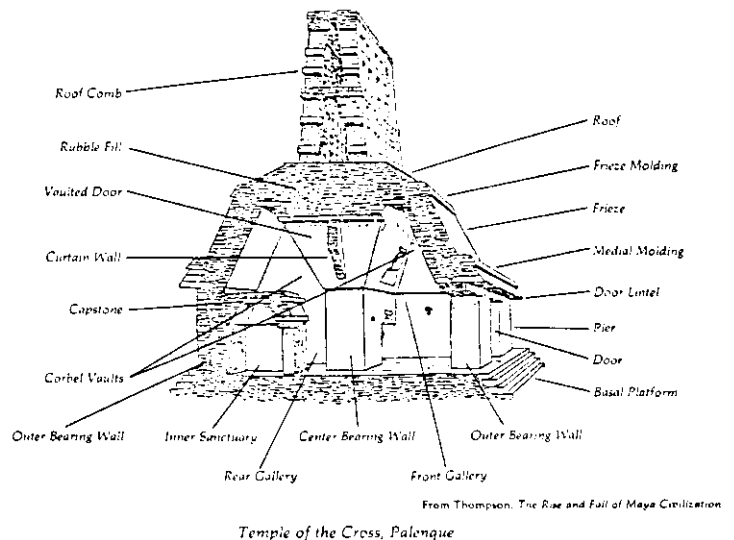

Fig 12a

slope of the exterior being roughly parallel to that of the interior vaults. the sloping surface of the upper wall is joined to lower vertical walls by means of a continuous string course which was altered to form a projecting cornice molding([Fig 12]Ferguson 1977).

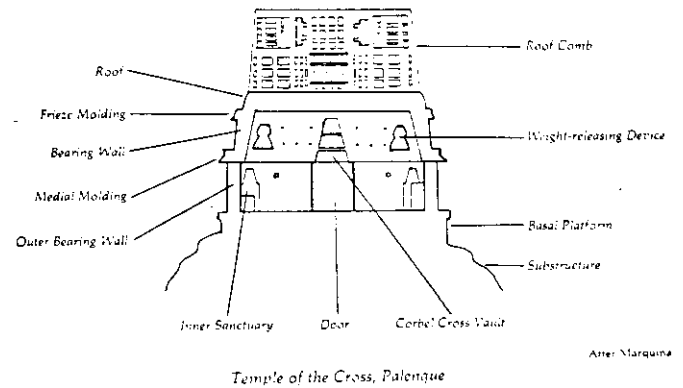

Fig 12b

The proceeding description of Mayan temporary and permanent architectures was given in order to establish a base for the premise that indeed Mayan classical architecture evolved from the traditional Mayan house. This evolution is not a direct translation of a wood architecture into a stone vocabulary, but a translation of spatial and spiritual qualities. "All temples in prespanish mesoamerica, even the towering pyramids of the Maya lowlands, are essentially nothing more than a magnification of the humble peasant dwelling-the simple rectangular house on its own flat mound([Fig 14]Coe 1966, p. 45). To the Maya the house itself is very holy thing, and it seems only natural that there formal religious architecture would be an adaptation of this form. A properly constructed and dedicated house is considered to have a soul, a soul that is more powerful than a persons. This is so because a house consists of elements derived from the Earth Lord(Vogt 1969). In the construction of a Zinacanteco house a cross is placed to the right of the doorway. The cross acts as a doorway to the soul of the house and anyone entering or leaving the home in a ceremonial context must stop and pray at the cross. The traditional Mayan house continues to carry a



Fig 13

significant religious aura and at times functions as a temple.

There is a direct proportional relationship between the interior spaces of the the Mayan house, and Mayan temple and palace architecture. The spaces created by the corbeled vaults of Mayan classical architecture are directly related to the spaces enclosed by the traditional house construction(Fig 15). The corbeled vault was not the only means of enclosing interior space known to the Maya, But it was the most prevalent. It has been stated that the maya lacked the knowledge to make the jump from the corbeled arch to the true or Roman arch. It is my belief that they possessed the knowledge, but did not wish to do so in keeping with the character of their traditional interior spaces. If you take the trefoil arch at Palenque as an example it would seem that the Maya did at times experiment with variations of the arch, but preferred the spatial quality given by the corbled vault. These variations of the corbled arch never gained wide spread use. I am assuming that this was due to a dissatisfaction by the Maya with their spatial qualities.

The correlation between the use of substructures is an apparent one emphasizing a strong relationship between the characteristics of the house and temple floor plans. This relationship goes beyond spatial similarities to those of function. Both the house and temple architecture is focused to activity which takes place within its immediate surrounds. With the

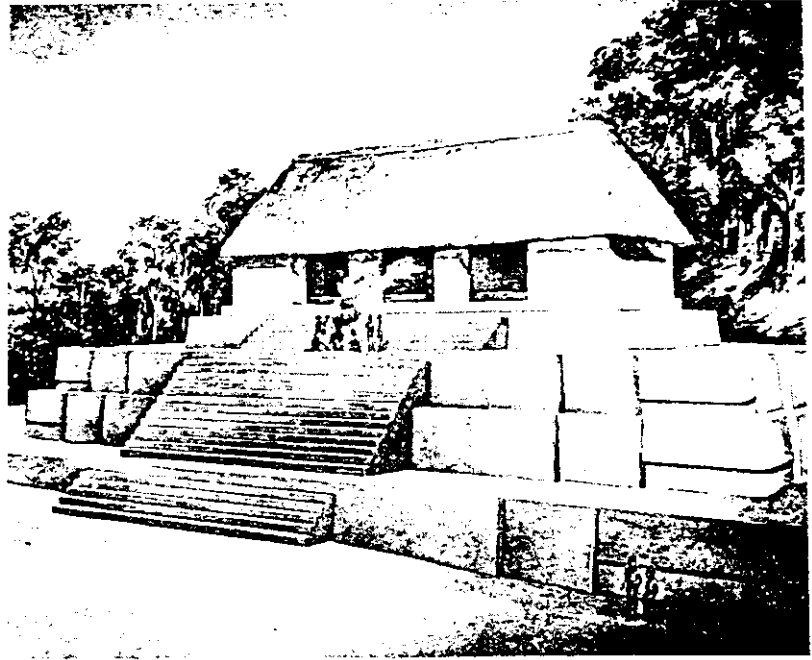

Fig 14

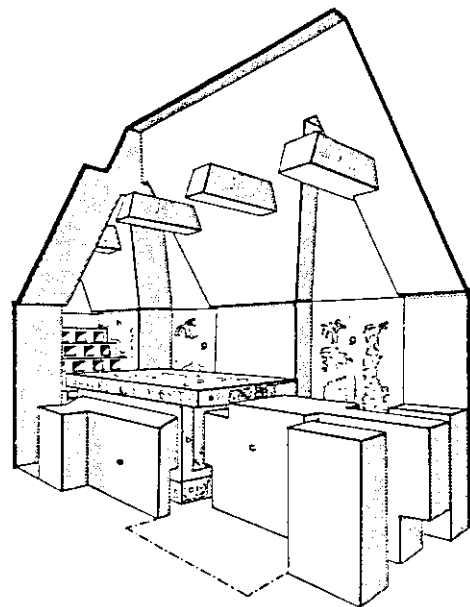

Fig 15

exception of extremely private and/or secret activities events take place within the boundaries of the substructures; and the porticoes or porches. the Maya classical architects themselves reinforce their reverence of the house form relying upon it as a source of many decorative motifs(Fig 16). If one carefully reviews the characteristics of the traditional Mayan house and those of classic Mayan architecture the similarities speak for themselves and are more than mere coincidence

PRELIMINARY CONCLUSIONS

Having established a direct link between Mayan classical and domestic architecture, thus gaining an understanding of these two forms and their relationship to each other, it is now possible to further the evolution of the Mayan vernacular building tradition beyond its present state. In doing so it is essential to create a positive aesthetic, but at the same time to go beyond the issues of aesthetic quality to those of the quality of life.

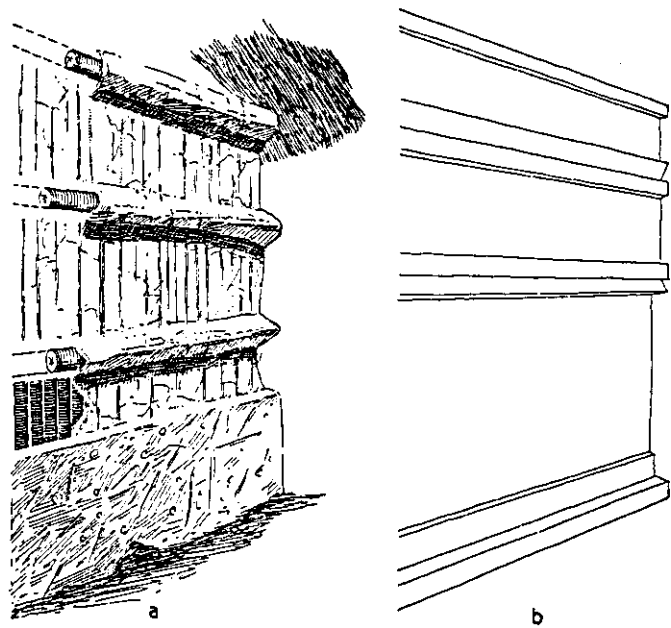

Fig 16

HOUSE AND TEMPLE PROFILES

THE ZINACANTAN MAYA

THE ZINACANTAN MAYA

Common sense should dictate that in order to successfully design an environment for a people it is necessary to understand them and their culture. However, more often than not we inflict ourselves upon those we claim to help. I have endeavored to become as familiar as I can with a people without living among them so that I may design for them with sensitivity. Direct field research is the best method for reaching this end, but not having the opportunity to visit Zinacantan I have relied upon previously compiled field studies which is a viable alternative to direct field research. However, it is best to visit the field when possible. There is no replacement for first hand observation.

THE MUNICIPALITY OF ZINACANTAN

Zinacantan is one of the twenty-one municipalities in the highlands of Chiapas, Mexico covering approximately 117 sq kilometers. The climate here is mild with a five to six month summer rainy season. The mean annual rainfall is 1171mm. Temperatures range between 22.5C(72F) and 17.5C(63F) during the summer months. temperatures can become quite cool during the winter dry season with the occasional frost. The municipality is dissected by the Pan American Highway. with San Cristobal being the nearest town of size. The settlement pattern consisting of a ceremonial center and outlying hamlets, where the majority of the

population resides, closely resembles that of the ancient Maya and is typical. The Mayan ceremonial and political centers of ancient times were inhabited only by the priests and ruling class. In the case of the Zinacantan center this pattern is reflected in the fact that there is not a large permanent indian population, although it acts as the seat of religious and political authority for the municipality. The Mexican municipal political structure has been superimposed upon the classical Mayan pattern. The population is approximately 8000 persons with no more than 400 of these residing in the ceremonial center of the municipality at any given time(Maps 3-6).

The ceremonial and political life of Zinacantan is focused at Zinacantan Center. It is literally the center of the Zinacanteco's world. The center is now laid out in a grid pattern an incidence not repeated anywhere else in the municipality. Here you will find three catholic churches San Sebastian, San Lorenzo, and the Hermitage of Senior Esquipulas, the administrative center(calbido), jail, a federal school, clinic, and several small stores(Map 7). The most important aspect of Zinacantan center is the sacred places in and around the center recognizing *tribal* gods. The movement between the center and hamlets is largely based on the desire to sell goods, and the need to come together for important religious and political functions. Zinacanteco religious practice is a mixture of traditional Mayan religion and

Map 3

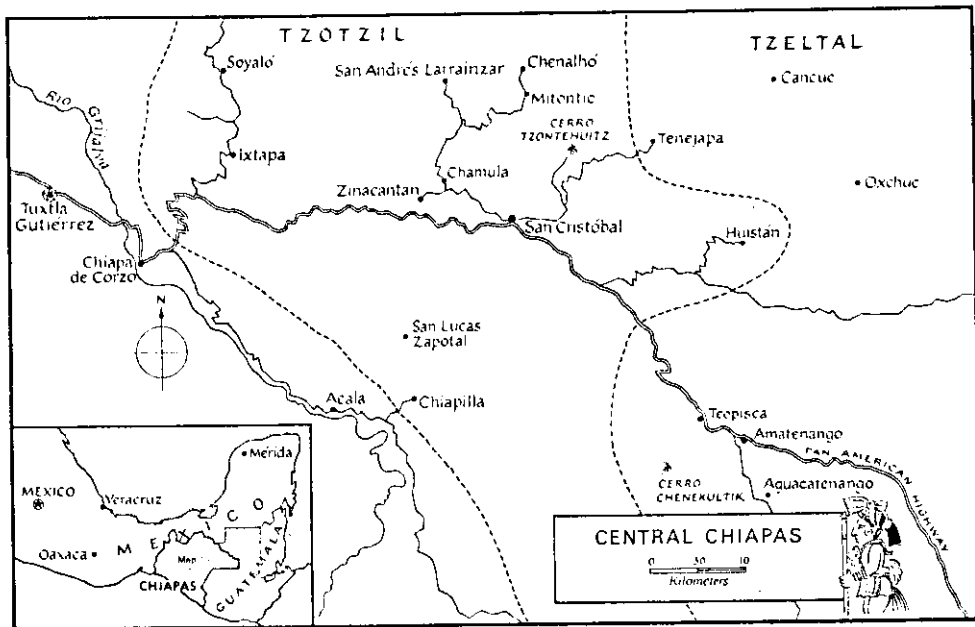

Map 4

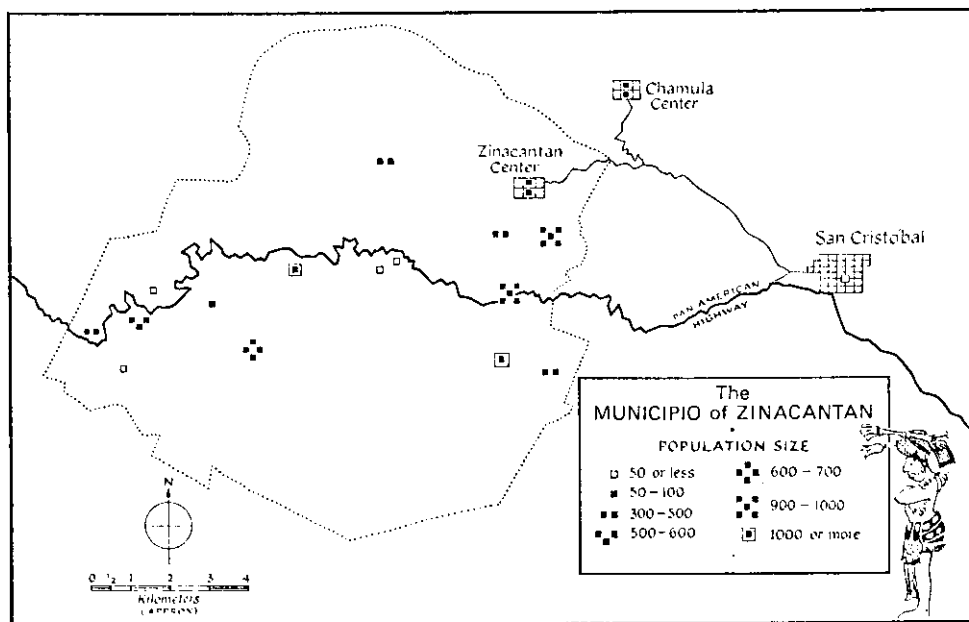

Map 5

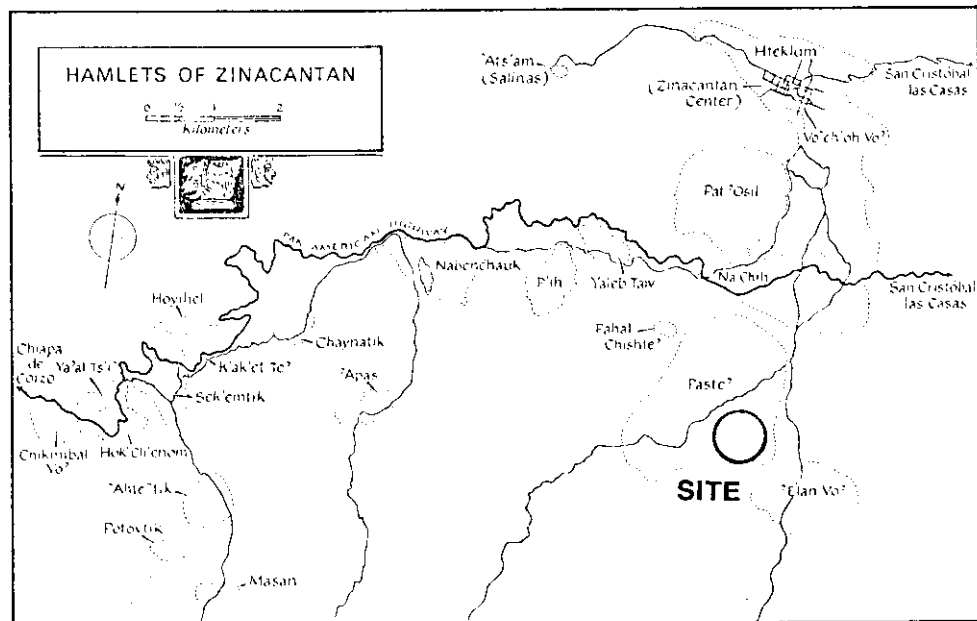

Map 6

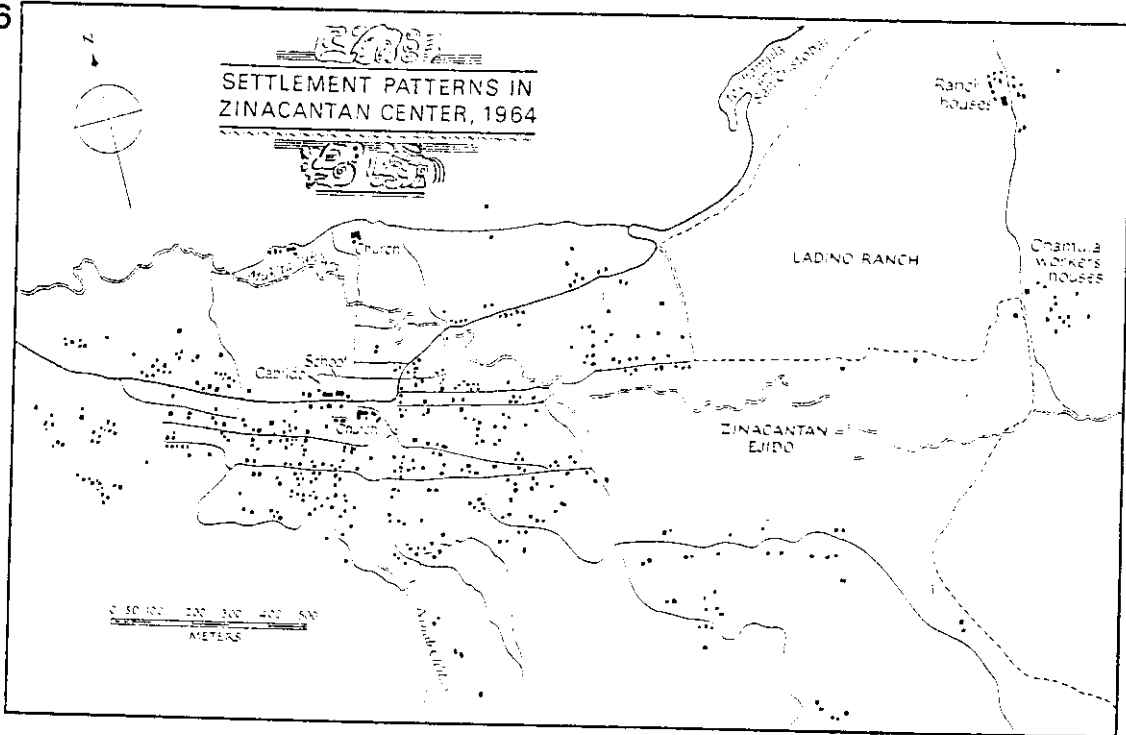

Map 7

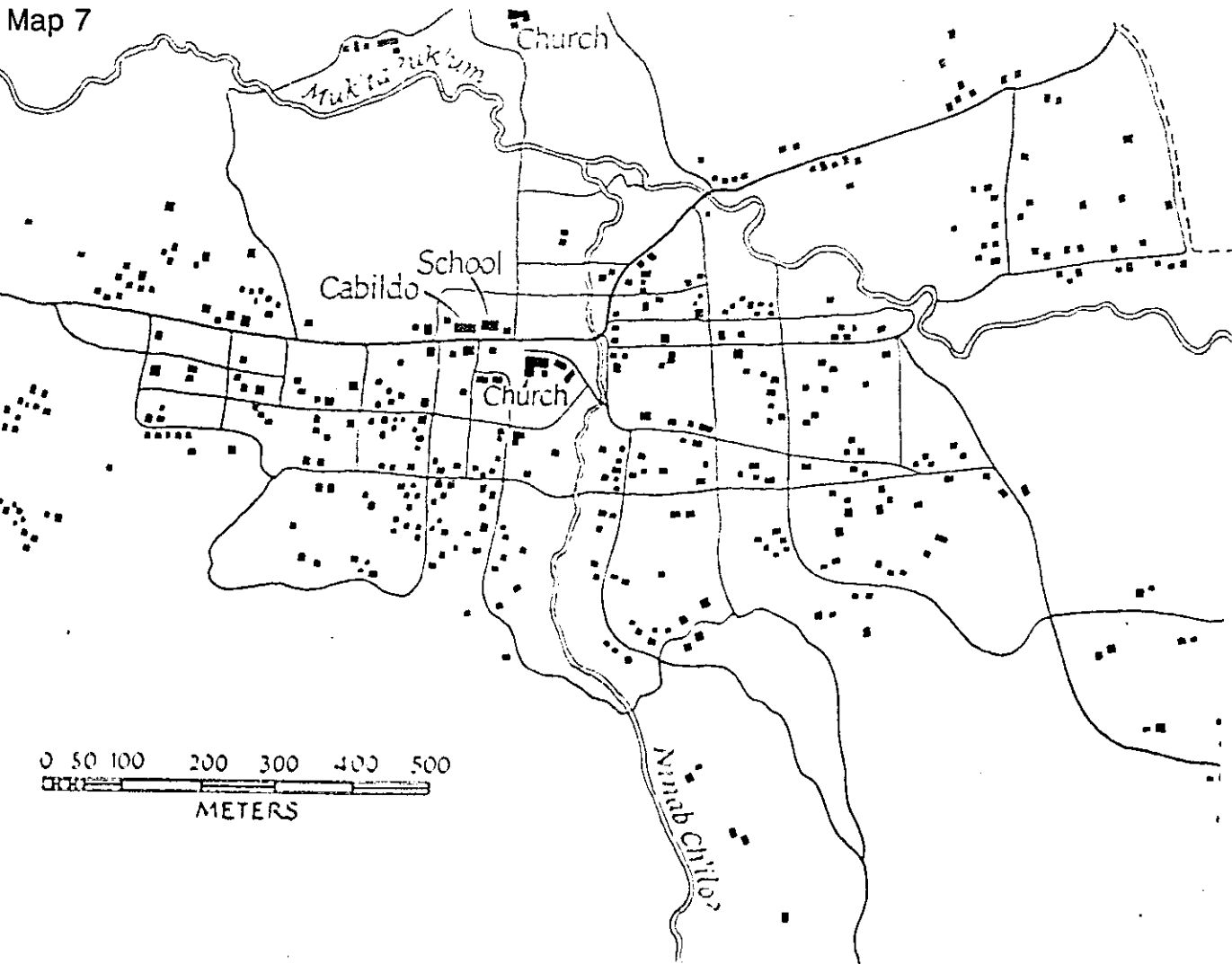

catholicism, and political power is a blend of *tribal* autonomy and federal rule. The municipality in, many ways functions in the same manner as the classical Maya city states.

ZINACANTAN SOCIAL PATTERNS

Zinacantan's fifteen hamlets can be broken into three basic social units of ascending size. These are the domestic group, the *Sna*, and the waterhole group. The domestic group is the basic unit of Zinacanteco society and is composed of related peoples living together within a compound sharing a single food supply. the independence of a house hold within a compound is represented by a house cross on the patio/terrace in front of the house. One house hold may occupy more than one structure, thus, a single house cross can represent several dwelling units. " The house cross serves as a *doorway* to the soul of the house, as well as a means of communication between the domestic group and the rest of the social system, between this small compound tucked away in a maize field and the outside world(Vogt 1969, p. 128)."

The domestic group can be pictured as a segment of a patrilineage. The Zinacanteco family is a patrilocal extended family living in one or more houses constructed around a common terrace sharing a single house cross. This system is marked by close economic and social cooperation between family units. The growth of the Zinacanteco domestic group is based on rules of



patrilocal residence and/or patrilineal inheritance. When a Zinacanteco youth marries he builds as close to his father as possible, either directly across the patio/terrace from his father or on land given to him by the father for this purpose. The eldest son marries first constructing his own home as soon as he is financially able. The youngest son being the last to marry inherits the initial house construction because he has cared for the father in his old age and provided for his burial. When it is no longer possible to locate directly adjacent to the house hold of the father the son builds as close as possible.



Built upon the domestic group the Sna is the next level in the Zinacanteco social structure. A Sna is defined as two or more domestic groups, or members of a common patrilineage living on adjacent land. Each Sna takes its name from the localized patrilineages; and when there is more than one lineage present the Sna takes the name of the predominate one. Regardless of the number of patrilineages within a Sna, or its history, the boundaries and composition of the Sna are reaffirmed through a religious ceremony performed each spring and fall for ancestral gods and the Earth Lord. Every Sna maintains a series of cross shrines performing a similar duty to that of the house cross, but these are for communication with ancestral deities and the Earth Lord instead of the *house soul*. The religious significance of the Sna as a part of the social order helps unify the Sna and insure its place in within



Zinacanteco society.

The next unit in the Zinacanteco social structure is the waterhole group comprised of two to thirteen Snas. The size of the waterhole group is dependent upon the availability of water for domestic use and the watering of livestock. During the five to six month rainy season the larger waterholes contain an ample supply, and along with smaller ones can support several households. However, many of the smaller water sources dry up during the winter months increasing dependency on fewer sources. The winter dry season forces the Zinacanteco to draw water for livestock and domestic use from the same point source. This is not the preferred practice. Waterholes are highly sacred with myths accompanying each of them, and each waterhole group maintains a series of shrines for the water source and the group itself. Each waterhole is reaffirmed in a manner similar to that of the Sna. This ceremony confirms the right of the waterhole group to draw from a particular source, and the communities obligation in maintaining it. The emphasis placed on the availability of a suitable water supply by the Zinacanteco reinforces the need to develop an alternative to the current dependency upon ground water sources.



The waterhole group, the Sna, and the domestic group combine to form the hamlet. Each level is a reflection of the other only with an increase of scale. The various levels of Zinacanteco society are a

result of an interdependency necessary for survival. The family structure of the domestic group is the basic cell of a complex socio-cultural organism.

DOMESTIC ARCHITECTURE

As the various levels of Zinacantan society are a reflection of each other Zinacanteco architecture is a mirror of the society it represents. The basic unit of Zinacanteco architecture is a single room rectangular house(NA) with an open fire or hearth for cooking food and heating the interior. The Zinacanteco consider the entire compound and its contents as a part of the Na not just the physical structure itself. There are three basic house types based on roof form. Type one is based on the gable roof, type two on the hip/pyramidal roof, and type three on the hip roof. The first two types follow more traditional Mayan construction techniques. They utilize the post and beam structural system outlined in chapter one with various types of thatch as roofing material. The wall system is non-load bearing composed of wattle and daub, split logs or branches, or mass adobe. The third type is a mixture of Mayan and Spanish American vernacular building traditions. This type uses load bearing adobe brick walls, and a wood shingle or spanish tile roof(Table 2). The aesthetic of the Mayan vernacular has lost favor among the Zinacantan Maya. Aesthetically the Zinacanteco prefer the image of the spanish tile roof and adobe walls. This is not a total rejection of the age old building

ZINACANTAN HOUSE TYPES

	ZINACANTAN HOUSE TYPES		
HOUSE TYPE			
ELEMENTS			
	HOUSE TYPE I- CHARACTERIZED BY GABLE ROOF W/GRADUAL PITCH AND A 1:1 OR 2:1 ROOF TO WALL SURFACE PROPORTION.	HOUSE TYPE II- CHARACTERIZED BY HIP ROOF W/ STEEP PITCH AND 1:1 OR 2:1 ROOF TO WALL SURFACE PROPORTION.	HOUSE TYPE III- CHARACTERIZED BY HIP ROOF W/GRADUAL PITCH AND 1:1 ROOF TO WALL SURFACE PROPORTION.
	ROOF SYSTEM UTILIZES POST AND BEAM CONSTRUCTION. TECHNIQUES W/VARIOUS TYPES OF THATCH AS ROOFING MATERIAL.	SEE HOUSE TYPE I	ROOF SYSTEM UTILIZES POST AND BEAM CONSTRUCTION. TECHNIQUES WITH PINE SHINGLES OR SPANISH TILE.
	WALL SYSTEM IS NON-LOAD BEARING WITH THREE TYPES OF CONSTRUCTION: WATTLE AND DAUB, SPLIT LOGS OR BRANCHES, AND ADOBE.	SEE HOUSE TYPE I	WALL SYSTEM IS LOAD BEARING ADOBE BRICK AND/OR MASS ADOBE.
	BASE CAN BE CUT/FILL TERRACE OR LOW PLATFORM. IN SOME CASES THERE IS NO DISCERNABLE BASE.	SEE HOUSE TYPE I	SEE HOUSE TYPE I

CLIMATE
 TROPICAL WITH FIVE TO SIX MONTH RAINY SEASON
 TEMPERATURE
 HIGH-72 F MEAN-68 F LOW-63 F
 PERCIPITATION
 HIGH-11.81" LOW-.39"

Table 2

traditions. The construction of this type has a sense of permanence about it, and the possession of a home that will stand the test of time is a mark of affluence among the Zinacanteco. However the more traditional Mayan house form responds with a greater sensitivity to the environment. And with the financial cost of this desired image of permanence it is beyond reach for most.

SUMMARY

The Zinacantan Maya are a proud people with a strong sense of self and their place in the scheme of things. In dealing with a people maintaining such a strong socio-cultural heritage it is not enough to simply provide a model for subsistence living they can achieve that themselves. Nor is it appropriate to impose our standards and

levels of technology upon them. One must define their basic needs and meet them within the cultural context as well as provide a pleasing architectural aesthetic. To do this it is necessary to look at the world not with rose colored glasses, but through the eyes of those we seek to help combining what we know with what we are taught.

THE DESIGN SOLUTION

THE DESIGN SOLUTION

There is one crucial point which I have stressed for myself in my efforts to design for the Zinacantan Maya. That is the necessity to respect the people I am trying to help. The Zinacanteco have a centuries old way of life with its own traditions and conceptual attitudes. You cannot go to a people and impose alien ideas upon them in the guise of improving their lot.

The foundation of the Zinacanteco lifestyle is their ability to help themselves; and the key to maintaining their current level of a subsistence and going beyond it is to foster and develop the concept of self-help. Any design solution for improving the quality of life of the Zinacantan would ultimately fail if it removed from them financial and technological control. Efforts should build upon societal systems already in place. With this idea in mind I have proposed a two phased master plan which is designed to improve the quality of life while leaving ultimate control in the hands of the Zinacanteco. The first Phase is the implementation of sanitation and water collection systems. The second phase is the construction of a housing prototype tailored to the growth pattern of the Zinacanteco family unit. This prototype will incorporate the systems developed in phase one and is to be used as an educational tool.

The site I have chosen is a large Sna in

the hamlet of Paste. It is a rural community composed of several domestic groups as outlined in chapter two

PHASE ONE MASTER PLAN

Phase one is a two fold approach to the improvement of the quality of life through an increased awareness of proper hygiene, and supplementation of the existing ground water supply. At present there is no method for the safe disposal of human body waste. As a solution I am proposing the construction of pit latrines at existing house sites. One per two family units. The latrine design is based on the Reed Odorless Earth Closet and utilizes a dual pit. Pit rotation allows for the proper disposal of wastes. As a pit reaches capacity it is sealed and the second pit is placed into use. After approximately one year the waste in pit one has composted and can be safely used as fertilizer and thus disposed of. At this point the second pit is sealed and the cycle repeated. An initial construction is to be undertaken with technical supervision as an educational exercise with ultimate responsibility for continued construction given to the Zinacanteco. The latrine with the exception of pit collar and squat plate can be constructed with readily available on site materials. The latrine base is earth fill with adobe brick side walls; and the screen walls are based on indigenous construction techniques and can be mass adobe or wattle and daub. The pit collar and squat plate are constructed of concrete and after proper education in the







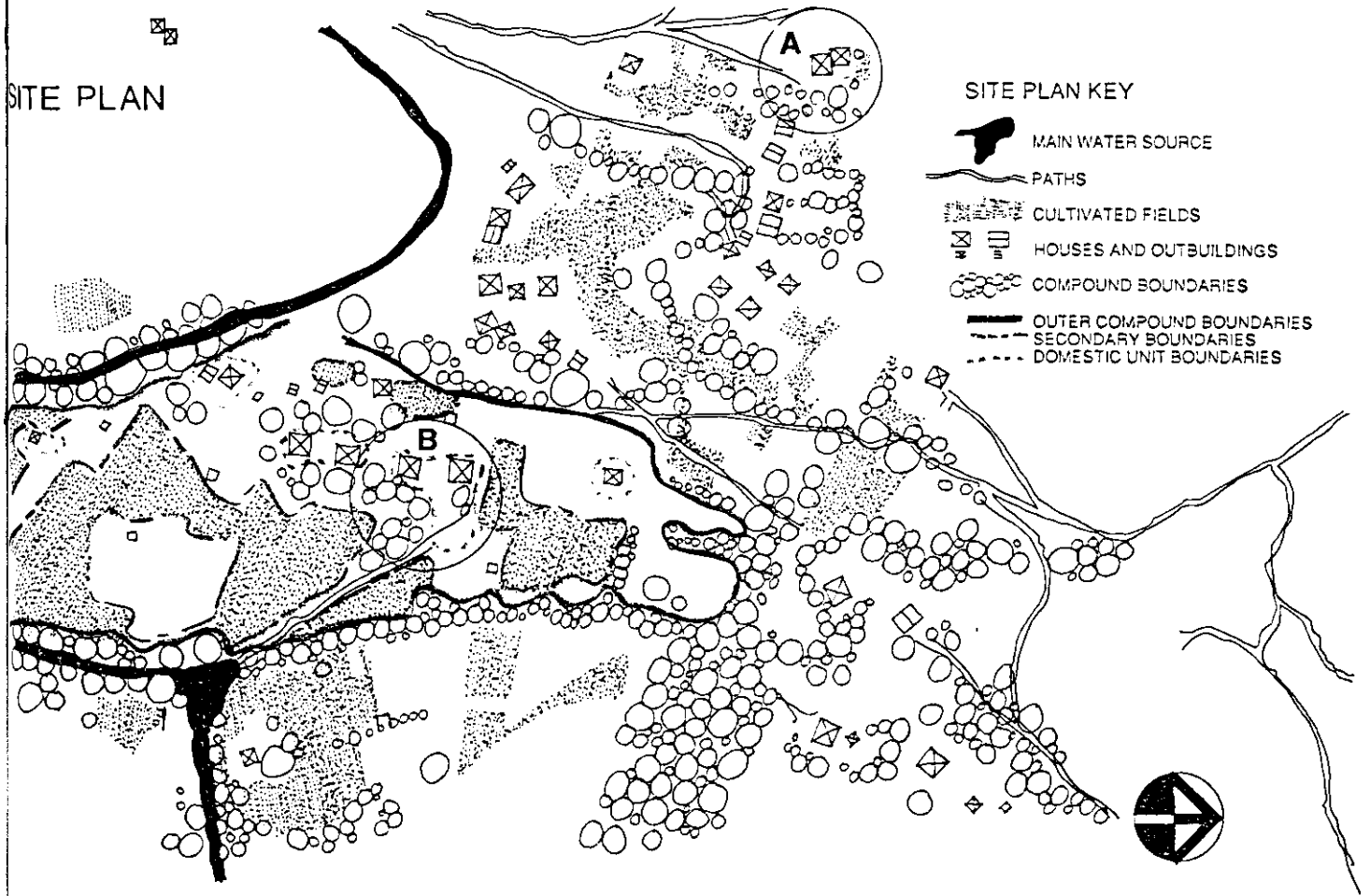

SITE LARGE SNA IN PASTE



SITE PLAN







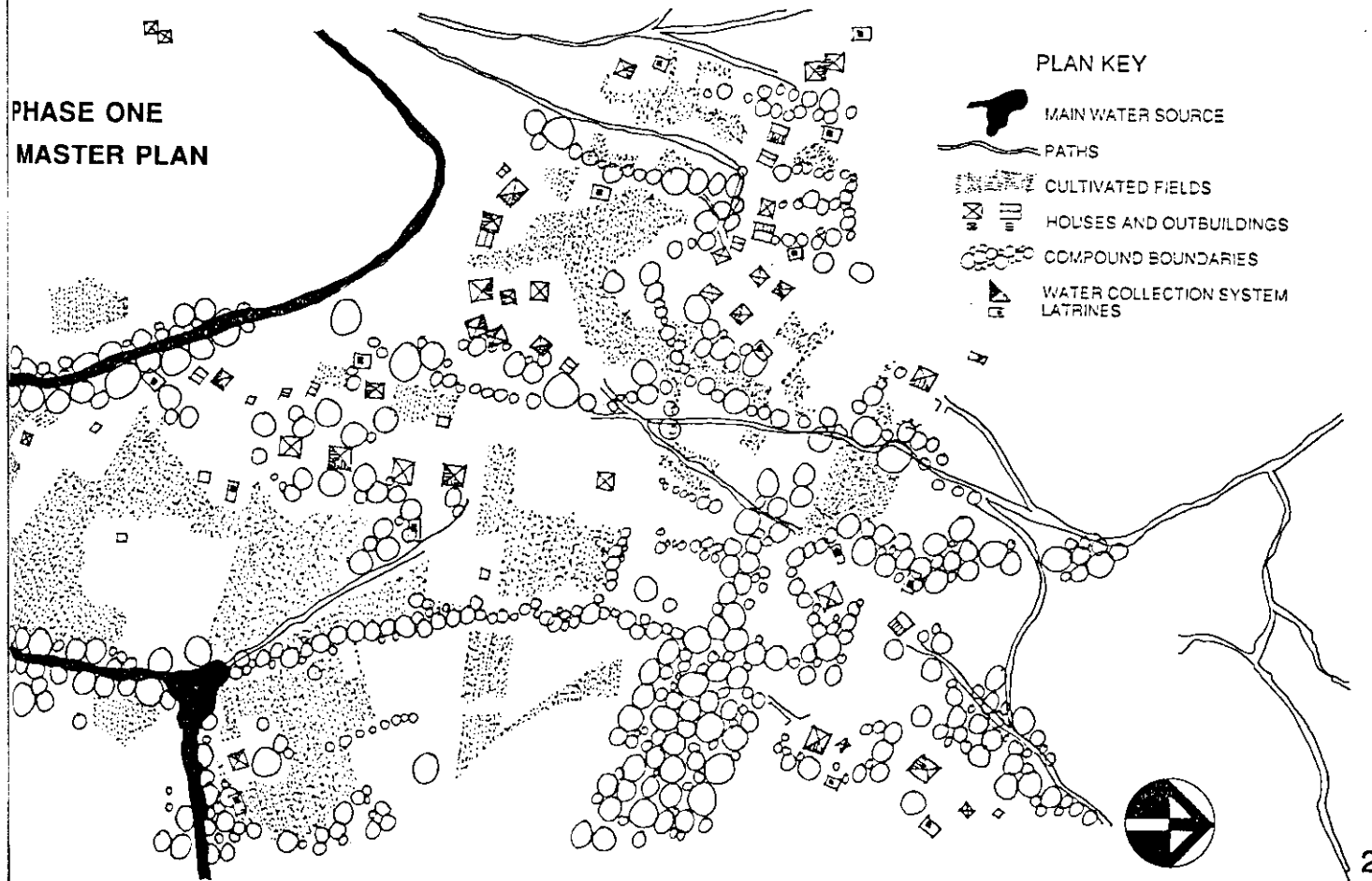

SITE PLAN KEY

-  MAIN WATER SOURCE
-  PATHS
-  CULTIVATED FIELDS
-  HOUSES AND OUTBUILDINGS
-  COMPOUND BOUNDARIES
-  OUTER COMPOUND BOUNDARIES
-  SECONDARY BOUNDARIES
-  DOMESTIC UNIT BOUNDARIES

PHASE ONE
MASTER PLAN



PLAN KEY

-  MAIN WATER SOURCE
-  PATHS
-  CULTIVATED FIELDS
-  HOUSES AND OUTBUILDINGS
-  COMPOUND BOUNDARIES
-  WATER COLLECTION SYSTEM
LATRINES

LATRINE

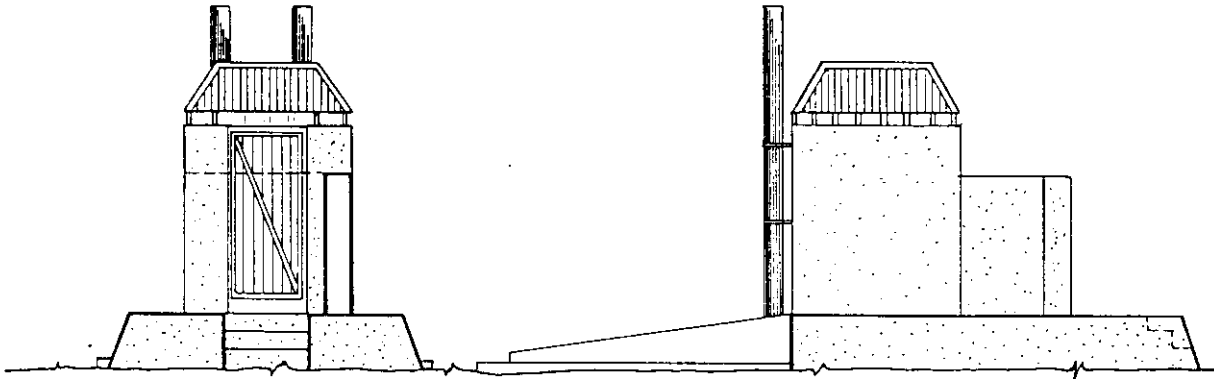

FRONT & SIDE ELEVATIONS

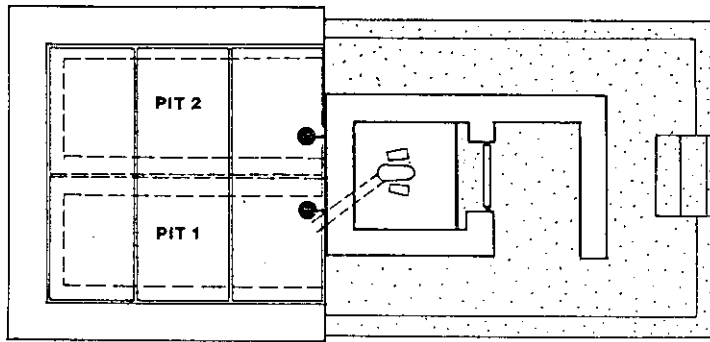

PLAN

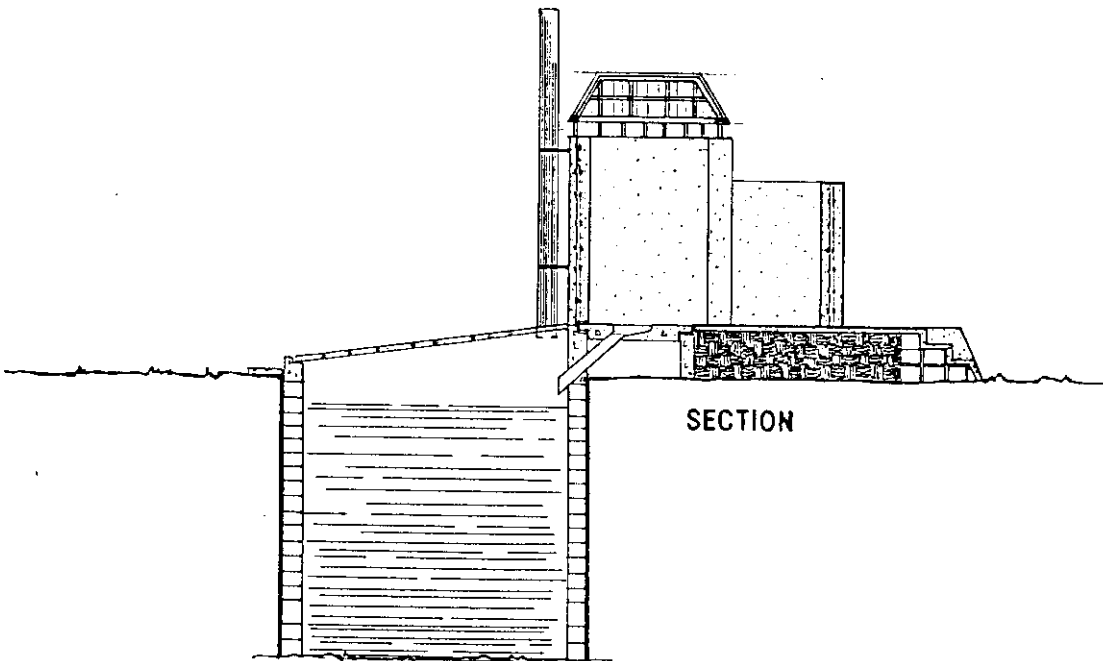
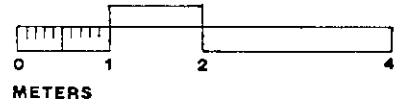

SECTION

PIT 1

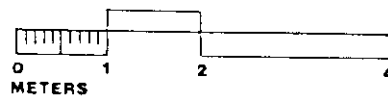

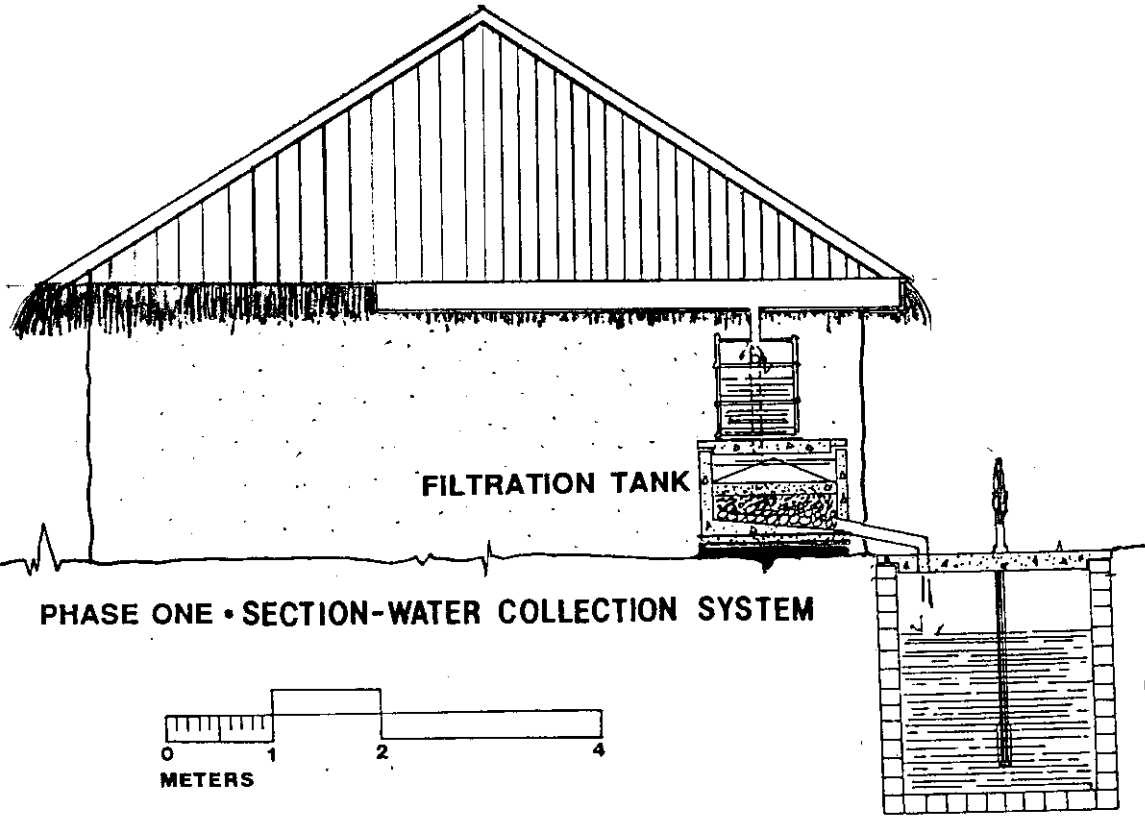

PHASE ONE • SECTION-WATER COLLECTION SYSTEM

CISTERN

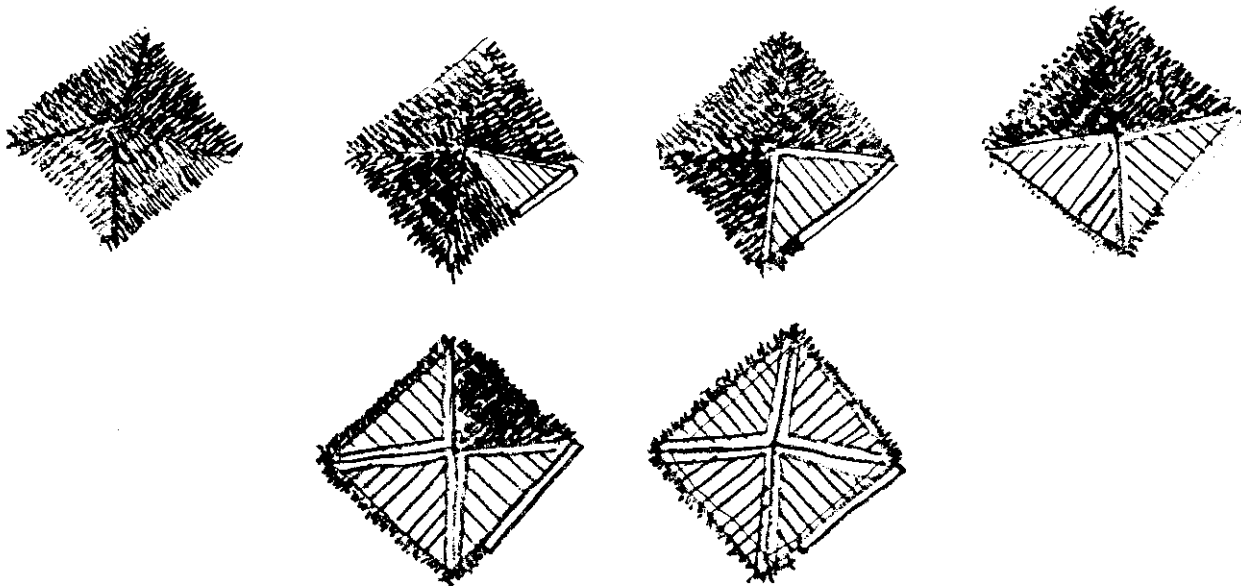
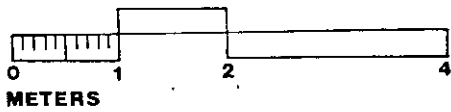

CONSTRUCTION SEQUENCE

making of form work etc. it is feasible for the Zinacanteco to be able to produce these elements as well. The Zinacantan presently utilize a crude form of concrete in limited applications.

The supplemental water system is based on the collection of rain water and has four main parts. These are the collection surface (galvanized corrugated metal sheets), initial storage tank (55 gallon drum), filtration tank, and cistern. In the case of existing construction the collection surface is to be added to the current thatch roof as an additional layer. The thatch itself is first sealed with a layer of embutido and then the galvanized sheet is placed. Only twenty-five to fifty percent of the roof need be covered for the purpose of water collection based on the families consumption rate. However, the entire roof can be enclosed as an upgrade of the current roofing system. All parts except for piping and the galvanized sheets can be manufactured on site. It is at this point that the level of outside assistance is set. Initial technological and general education is to be provided by an outside agency with all on site programs eventually being turned over to the Zinacanteco. Mexico in general is an industrialized nation therefore the availability of piping and roofing materials should not be a problem. This is the area of greatest long term cost, and also the area where outside assistance may need to be continued for a longer period of time.

PHASE TWO MASTER PLAN

Phase two is the construction of a new housing prototype following the societal growth patterns as outlined in chapter two. Construction is to be undertaken with the cooperation of an Zinacantan family which is at a stage of growth requiring the start of a new housing cluster. The prototype is based on Zinacanteco building practice, and utilizes the existing spatial relationships within the traditional house compound. This prototype also incorporates the systems outlined in Phase One.

Within the Sna I have selected as a site there are two basic compound patterns. Each is denoted by a series of overlapping spatial boundaries. The first of these is the compound boundary indicated by treelines. The second is the edge created by the fields, and the third is the area immediately surrounding the house construction and contains the patio/terrace. I have designated the compound patterns as Type A and Type B. Type A is based on the juxtaposition of two dwelling units with a common patio/terrace on the entry front. Type B is based on two dwelling units facing each other across an open patio/terrace space. In response to these two compound types I have developed a master plan based on the spatial relationships of both.

PHASE TWO
MASTER PLAN A



PHASE TWO
MASTER PLAN B

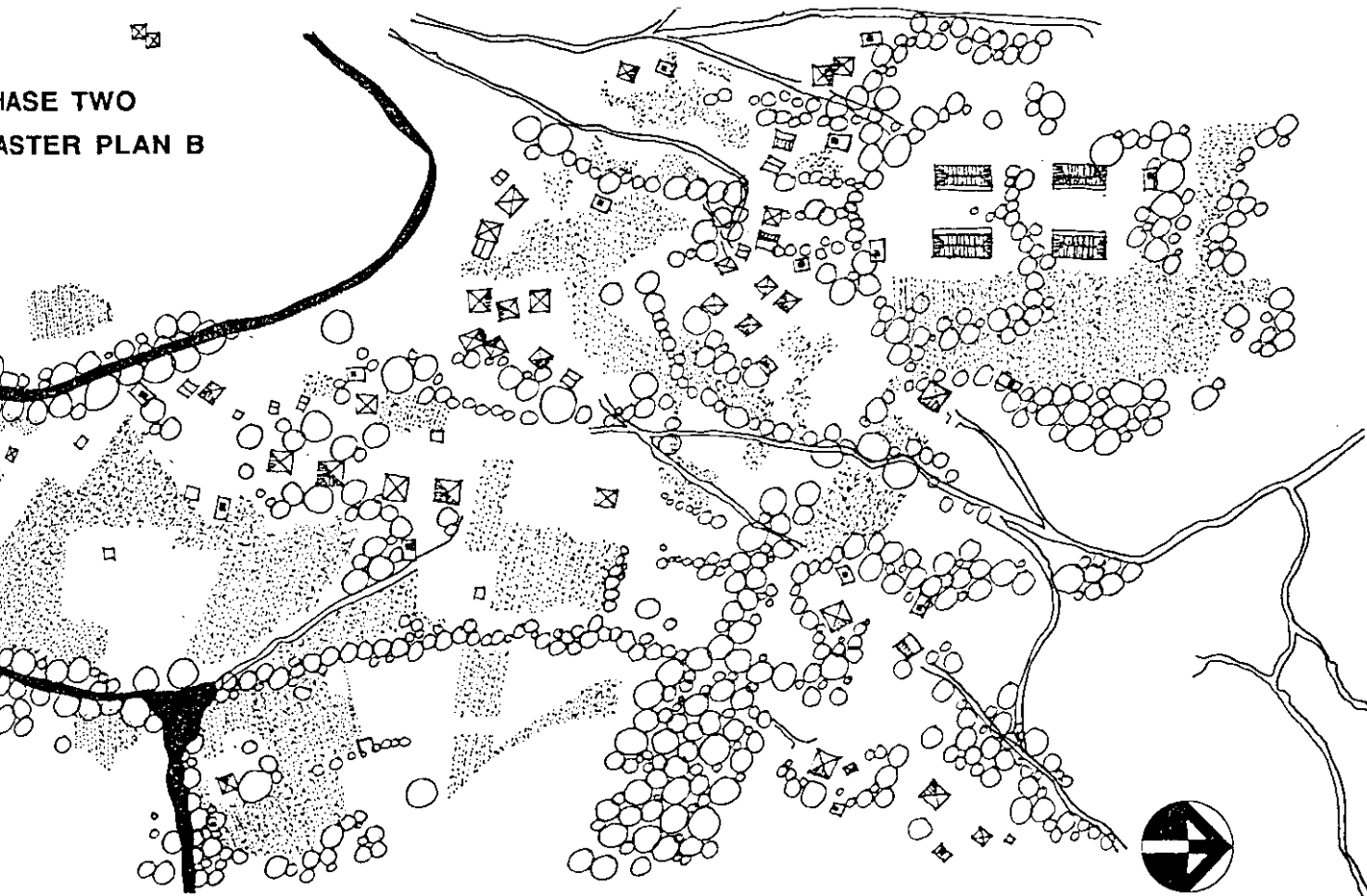

EXISTING COMPOUND-TYPE A

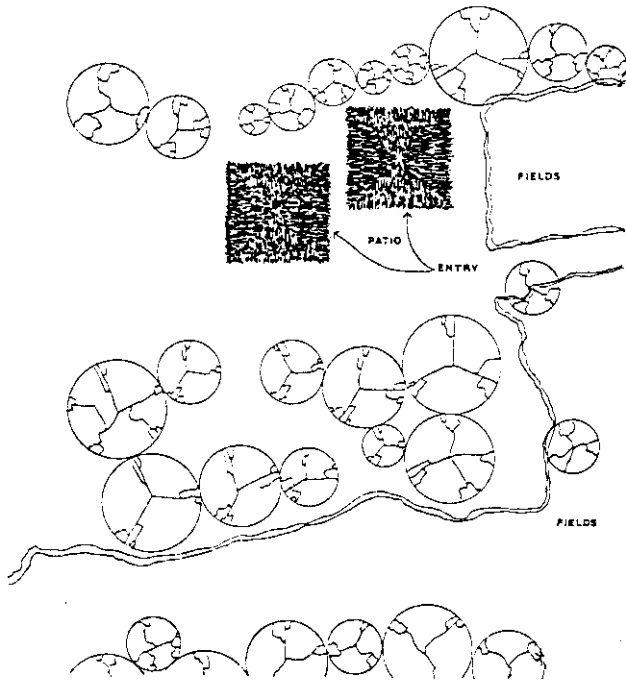

EXISTING COMPOUND-TYPE B

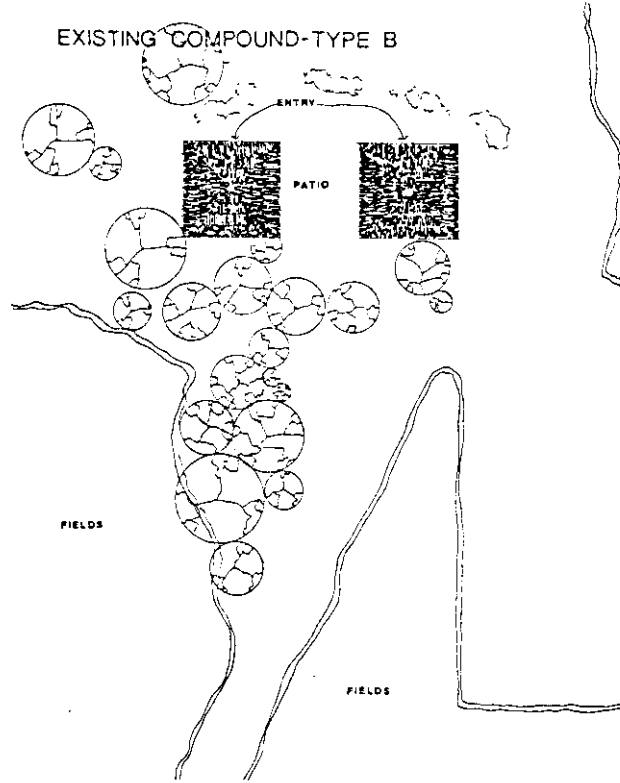

NEW COMPOUND-TYPE A

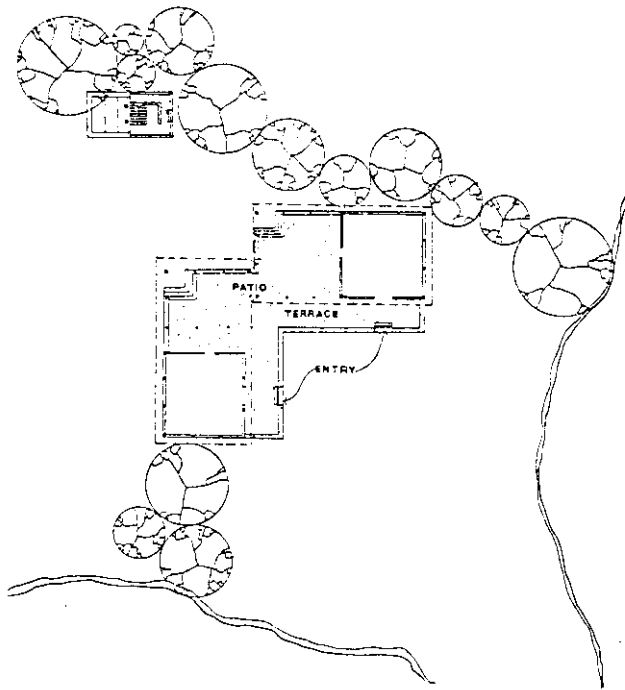

NEW COMPOUND-TYPE B

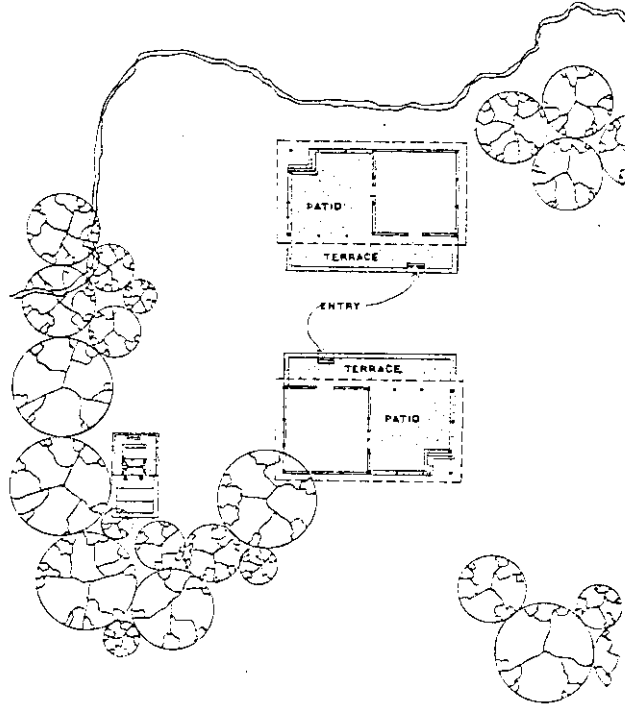

THE ZINACANTAN COMPOUND

The land area surrounding the Zinacantan house has an equal importance to that of the interior space. Exterior space, however it may be defined, by fence or geographic barrier is an essential part of Zinacantan architecture. Access to the inner sanctum of the Zinacantan home is through these spaces as a series of layers or boundaries. These spatial layers are the outer boundaries of the compound itself, the area controlled by a particular group of domestic units (secondary boundary), and the patio/terrace which is an extension of the interior space. Of these three the patio has the most significance. It is here that guests are often entertained, women weave, and other small tasks are performed. The interior space of the Zinacantan home is reserved for the sanctuary of the family thus giving great importance to the patio and the concept of such a space.

NEW COMPOUND-TYPE A

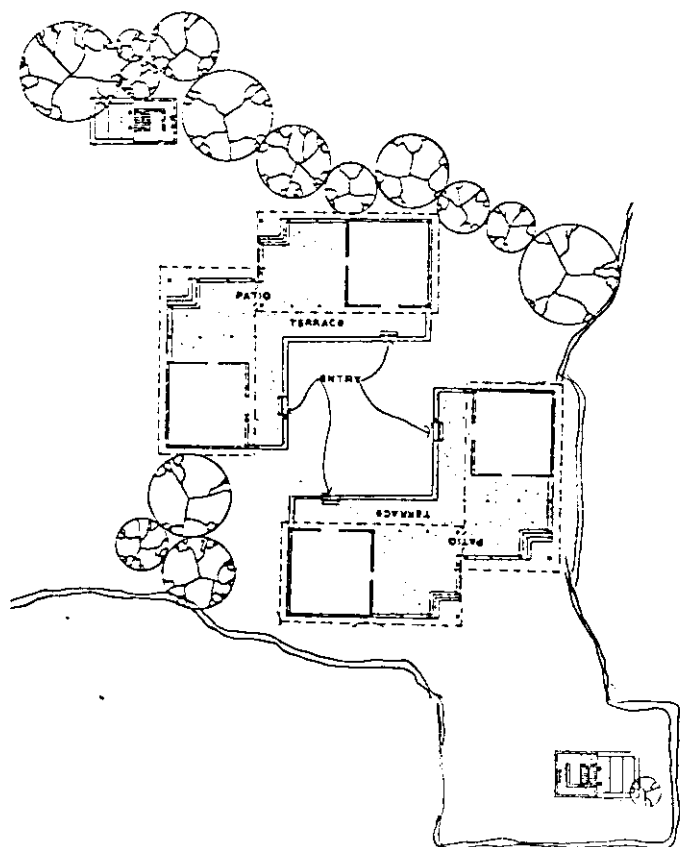
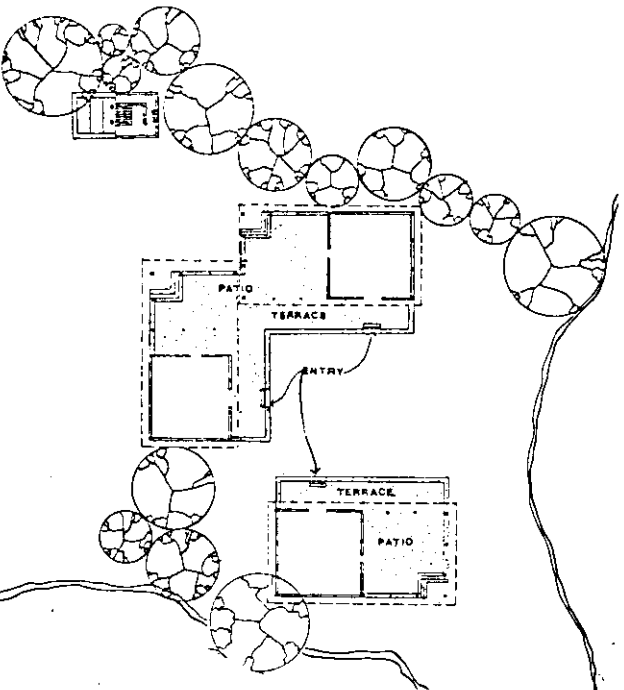
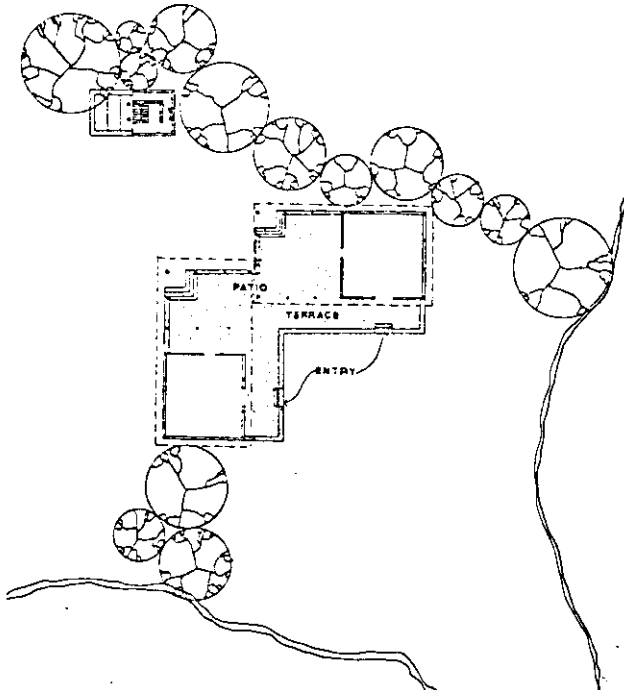
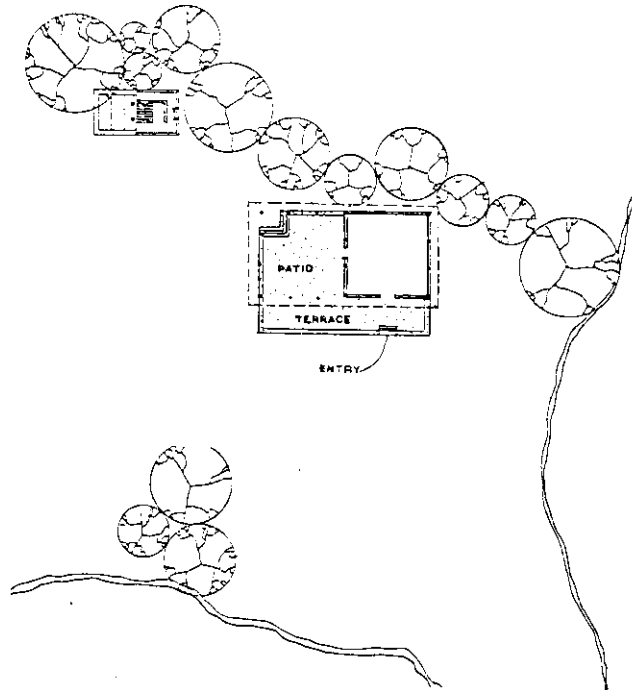

UNIT PROTOTYPE GROWTH PATTERN

UNIT PROTOTYPE CONSTRUCTION SEQUENCE

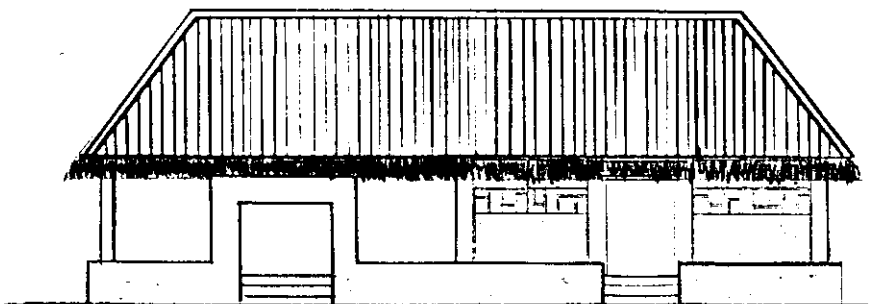
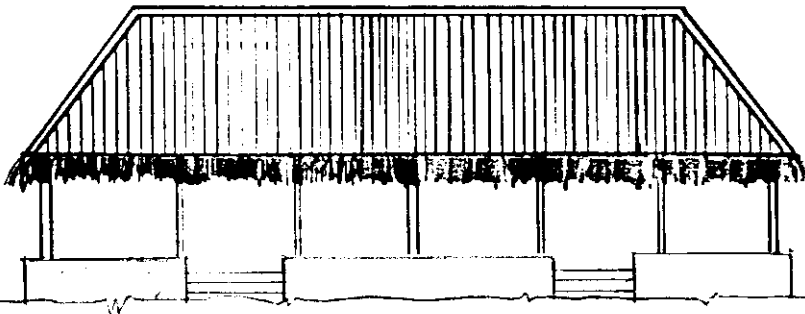
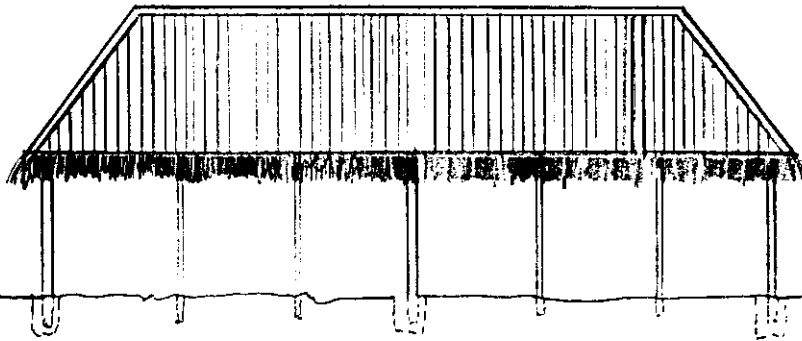
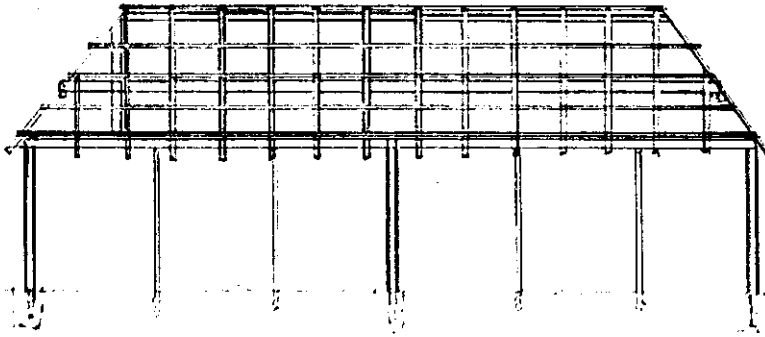

THE UNIT PROTOTYPE

The individual unit is designed on the premise that the Zinacanteco family group is the basic cell of a complex societal organism. Thus, any successful housing form must be able to grow with the basic family unit. The unit prototype I propose utilizes the existing Zinacanteco concept of space growing to a four unit housing cluster. The construction of the individual units is taken from traditional methods of house construction as outlined in section one. What I have endeavored to do is evolve the vernacular architecture of the Zinacanteco beyond its present state; and in doing so increase the Zinacantecos awareness of hygiene along with their comfort of living.

Each unit is composed of a small elevated platform containing a one room

living space, a covered patio, and a terrace. The spatial arrangement mirrors that of the compound and is set up in layers. The space flows from public to semi private and to private, but are contained within the units physical boundaries. The base is a compacted earth fill with adobe brick retaining walls surfaced in embutido. The framing system is the traditional post and beam system of construction translated into cut lumber. The thatch roofing material has been combined with galvanized corrugated metal sheets to create a hybrid roofing system with dual purpose. This system adds to the longevity of the roof enhances its thermal properties and decreases long term maintenance costs. It also functions as part of the supplemental water system. The wall system of the prototype is non-load bearing allowing for each builder to design them as he sees fit. This is in an

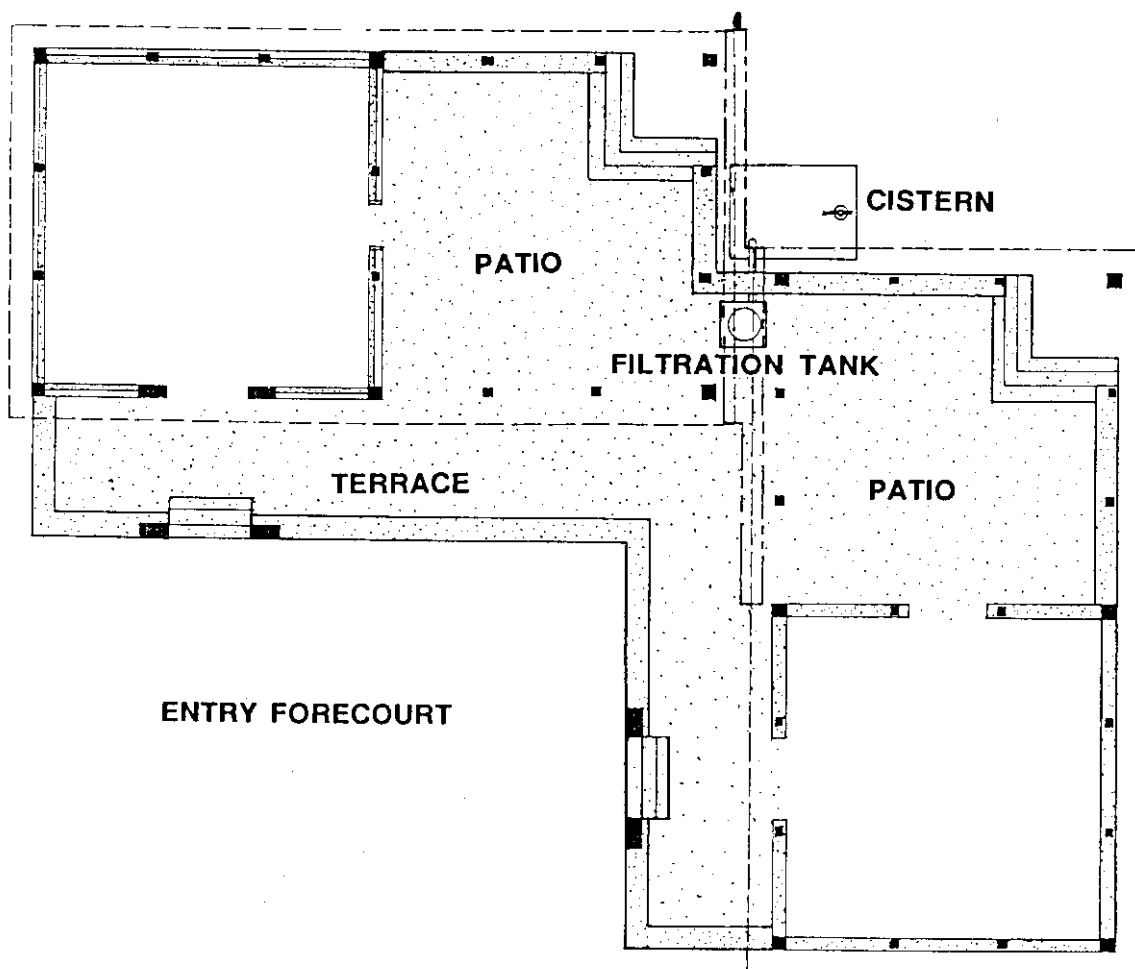

space plan

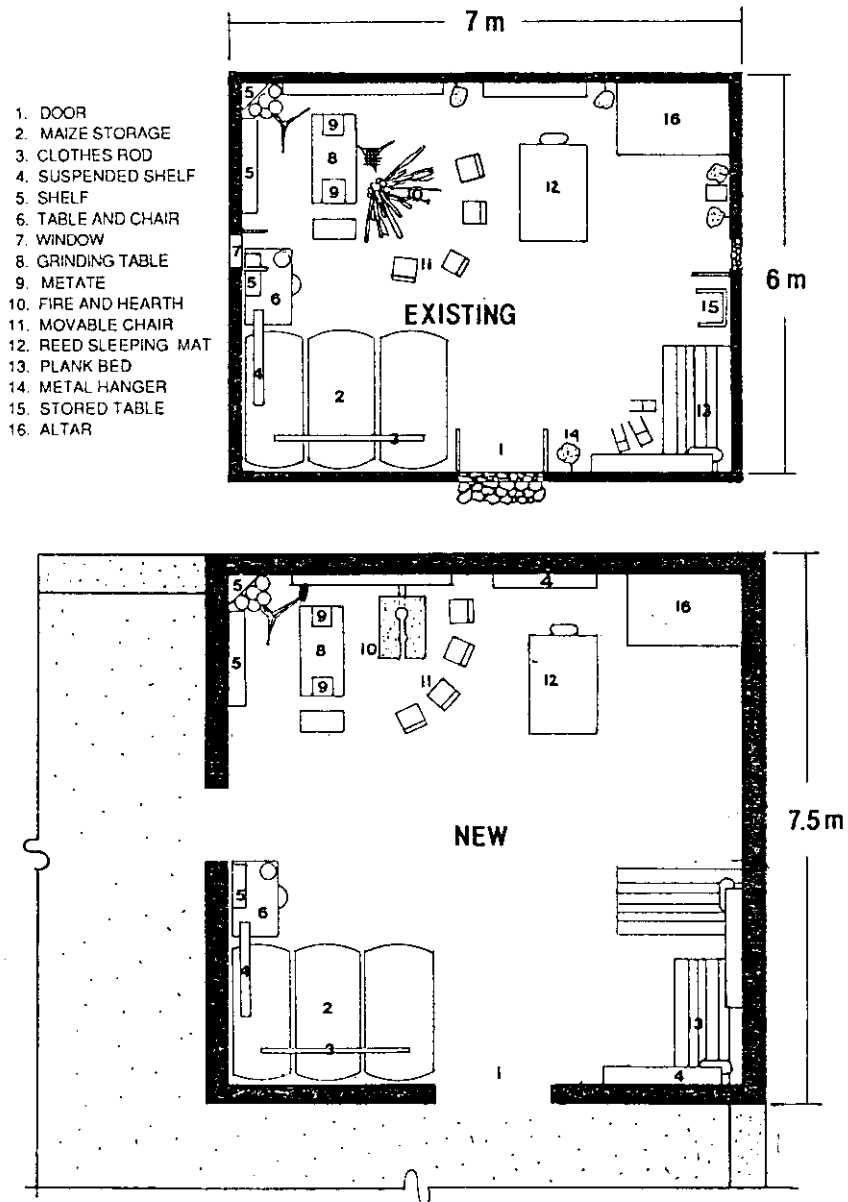

effort to push the Zinacanteco to use their existing art forms and perhaps help them revive some of the lost traditions present in their historical architecture. Here there is the chance to combine various materials and textures, to utilize screen walls with decorative weaving patterns, to practice elaborate geometric patterning in efforts to

recapture the lost formal aesthetic of their heritage. The total concept of the unit prototype is to provide a basic structural and spatial system that allows for some individual interpretation and manipulation in the spirit of the existing vernacular tradition.

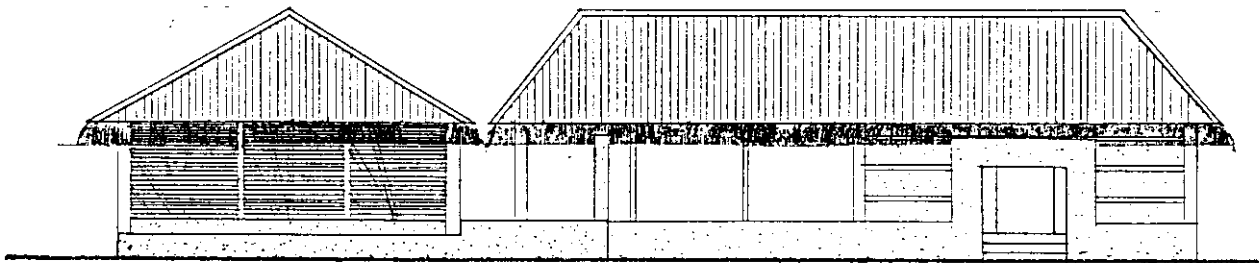

FRONT ELEVATION

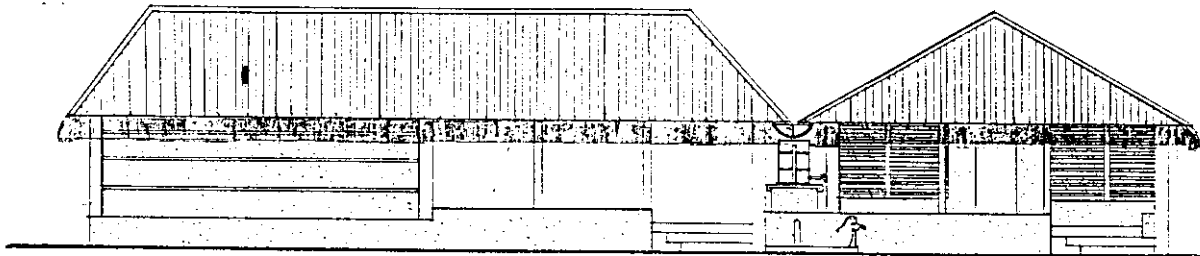

REAR ELEVATION

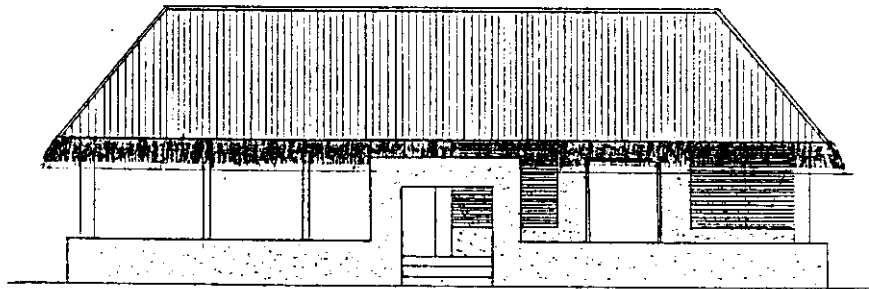

FRONT ELEVATION STUDY

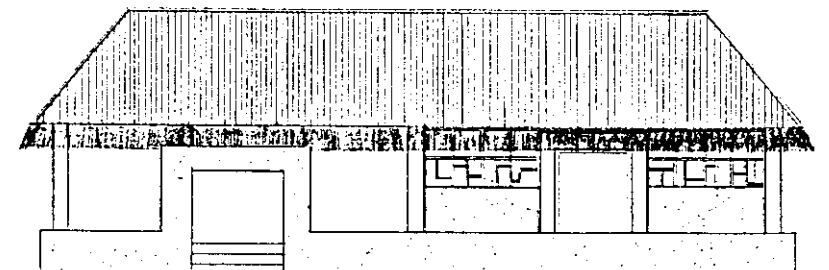

FRONT ELEVATION STUDY

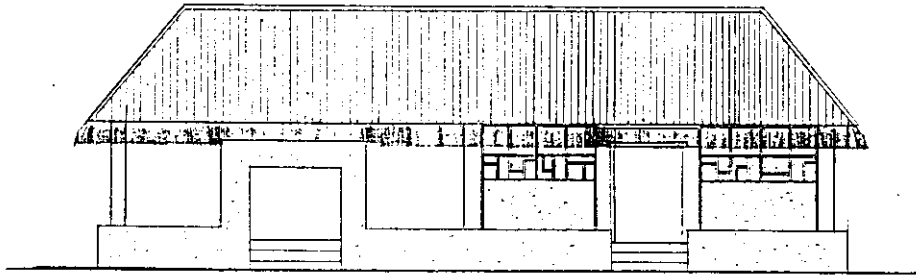

FRONT ELEVATION STUDY

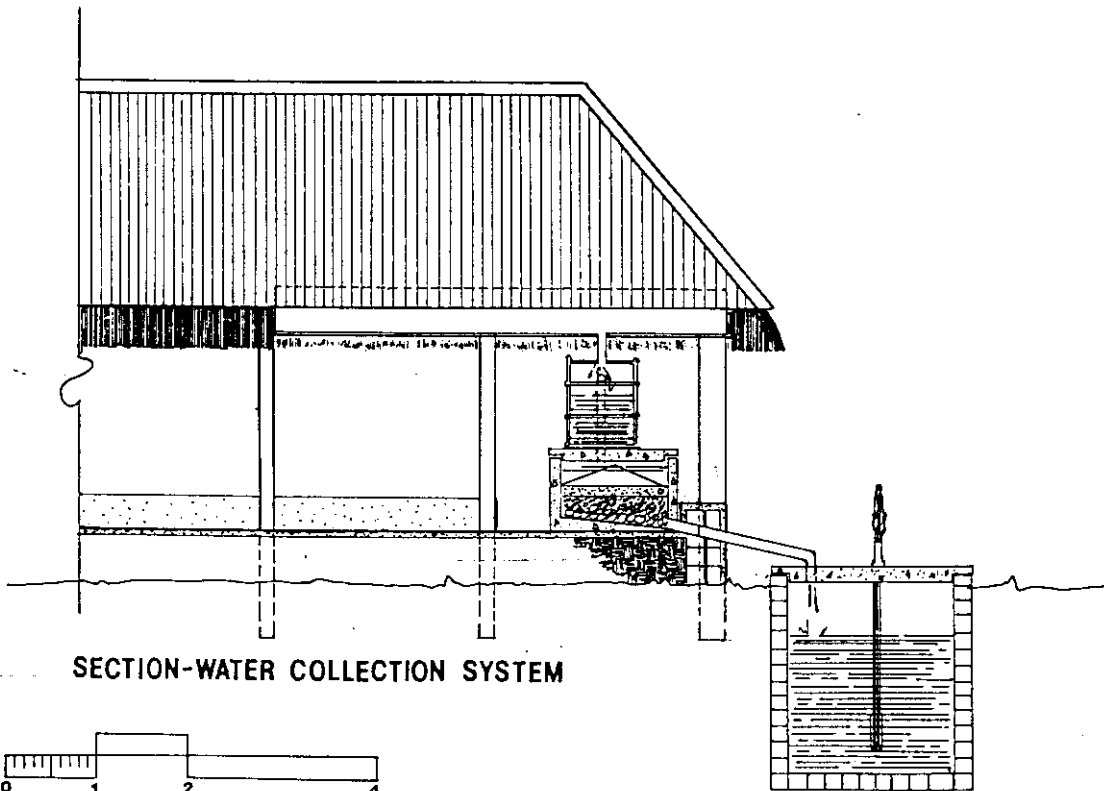

SECTION-WATER COLLECTION SYSTEM

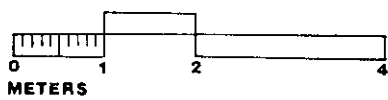

CONCLUSIONS

This inquiry began as an acknowledgement of the fact that we as architects can not, must not, limit ourselves in what we recognize as our architectural heritage. To deny what has passed before blocks the path which lies ahead.

In any context it is impossible to successfully reach a design solution without knowing the underlying socio-cultural environment. This does not simply apply to extremes such as my efforts with the Zinacantan Maya, but to the environments which are most familiar. Any architectural problem undertaken has its own character derived from inherent socio-cultural patterns including building traditions. However, it is not as simple as copying a style or falling into a contextual historicism. The environment exists as a educational tool, and a source of inspiration. The socio-cultural environment sets the parameters of design and gives a foundation for the ultimate design solution. My design work for the Zinacantan Maya was based on these principles.

In an effort to be sensitive to the Zinacanteco way of life and its vernacular building traditions I at first failed to go beyond it. My initial

design was only a restatement of this vernacular with a nostalgic attitude toward its aesthetic. Architecturally I had created a pleasing image, but failed to meet the larger criteria of improving, through architecture, the quality of life. It is easy to become overwhelmed by one's desire to respect socio-cultural ideals, and in turn loose focus. To overcome this tendency I began to think in terms of a system that would combine architectural aesthetics with societal needs. From this point it was possible to develop a design solution that evolved from the vernacular tradition an affected an improvement in the quality of life. The principles explored here can be utilized in any environment. It is the combination of architectural experience from various sources which bring to life innovative architectural solutions.

BIBLIOGRAPHY

Coe, Micheal D. The Maya, New york, Frederick
A. Praeger; 1966.

Gallenkamp, Charles. Maya: The Riddle and Rediscovery of
a Lost Civilization, New York, Viking Press; 1985.

Ferguson, William M. Maya Ruins of Central America in Color,
Albuquerque, University of new Mexico Press; 1984.
Maya Ruins of Mexico in Color, Norman, University of
Oklahoma Press; 1977.

Potter, David F. Maya Architecture of the Central Yucatan
Peninsula, Mexico, NewOrleans, Middle America Research
Institute; 1977.

Rivet, Paul. Maya Cities, Great Brittain, Elek Books Limited; 1960

Thompson, J. Eric S. The Rise and Fall of the Maya Civilization,
Norman, University of Oklahoma Press; 1966.

Totten, George O. Maya Architecture, Washington D.C., The
Maya Press; 1926.

Wauchope, Robert. Modern Maya Houses, Washington, D.C.,
Carnegie Institution of Washington, 1938.

Vogt, Evon Z. Zinacantan: A Maya Community in the Highlands of
Chiapas, Cambridge, The Belknap Press; 1969.