

**USING ARCHITECTURE AS AN ENHANCER
AND REINFORCER OF SPIRITUALITY**

UNITED METHODIST SEMINARY

AN ARCHITECTURAL THESIS

**BY TODD ALLEN GINDELBERGER
COLLEGE OF ARCHITECTURE AND PLANNING
BALL STATE UNIVERSITY**

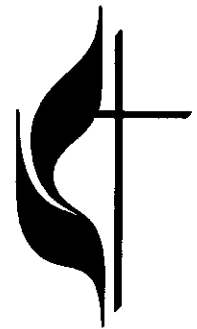

**USING ARCHITECTURE AS AN ENHANCER
AND REINFORCER OF SPIRITUALITY**

UNITED METHODIST SEMINARY
OSCEOLA, INDIANA

AN ARCHITECTURAL THESIS

BY TODD ALLEN GINDELBERGER
COLLEGE OF ARCHITECTURE AND PLANNING
BALL STATE UNIVERSITY

DR. BRUCE MEYER PROFESSOR JACK WYMAN

NOVEMBER, 1987

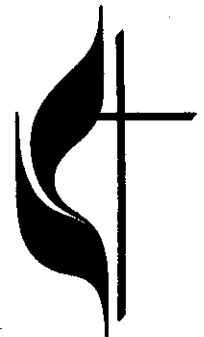

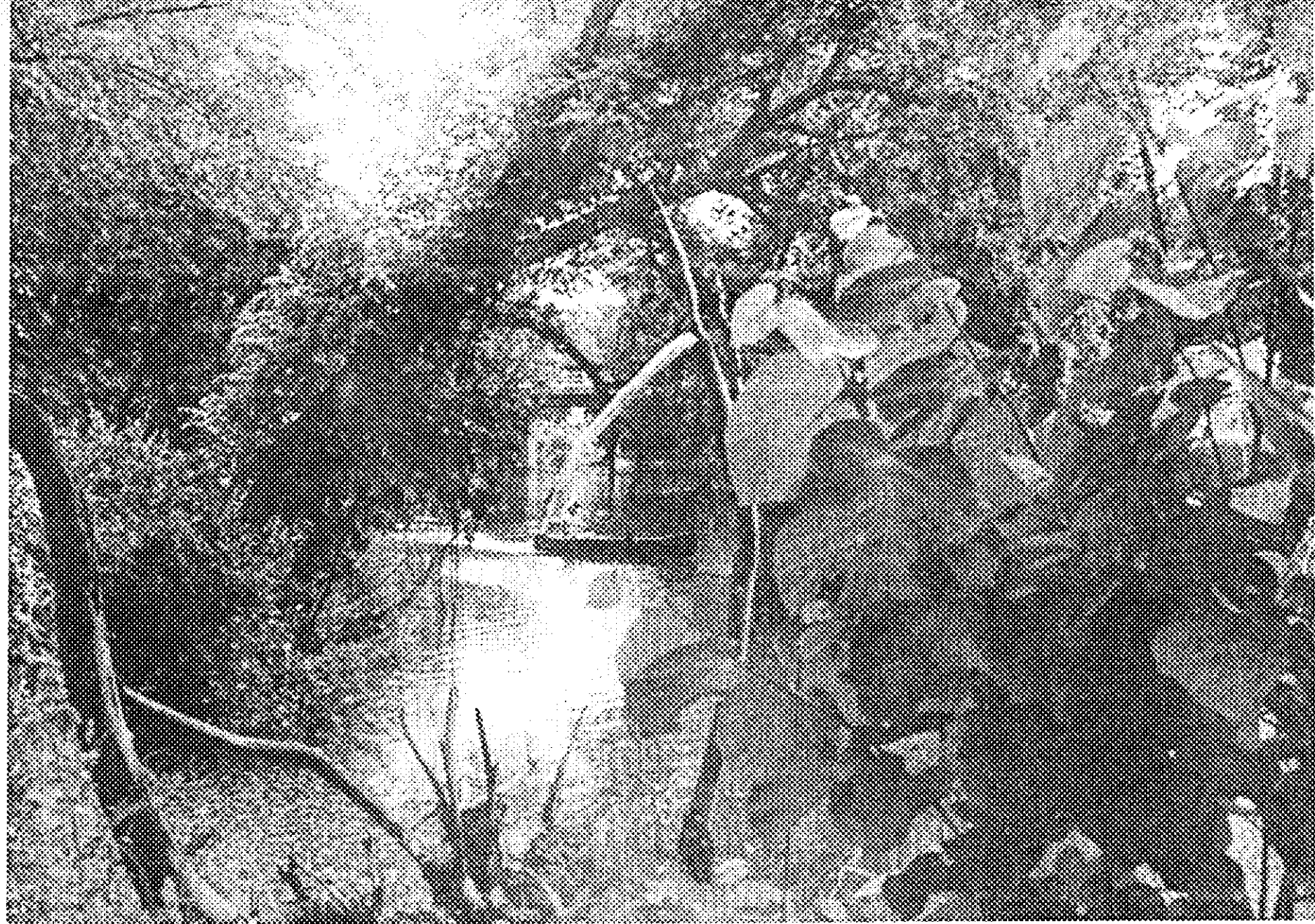

Dedication

I dedicate this project to God and Jesus Christ
without whom I could not have completed this
project.

This document is representative of a nine month architectural thesis study. Its main objective is to take an intensive look at an issue concerning architectural design, the use of architecture as a reinforcer, an enhancer of human spirituality and then to test my findings in an actual and original series of design projects involved within a protestant (Methodist) seminary. This thesis is by no means the answer to a problem. It is intended to be a way of increasing mine and, hopefully, other's awareness of an issue and show a possible alternative to the applications of my findings.

Table Of Contents

Dedication iii

Abstract iv

Thesis 1

 Thesis Argument, Intent And Statement 3

 Definitions Of Spirituality 4

Design 5

 Project Description, Justifications
 And User Identification 7

 Site Choice 9

 Overall Design Approach 10

 Campus Master Plan 11

 Chapel 16

 Dinning Hall/Student Union 27

 Single Student Housing 36

Appendix 43

 Notes And Construct Studies 45

 Regional Analysis 50

 City Context Analysis 51

 Site Photos 52

 Site Analysis 62

 Site Zoning 63

 Site Plan And Precedence Studies 64

 Site Details And Precedence Studies 69

 Site Design Process 72

 Campus Element Relationships 74

 Chapel Notes And Precedence 76

 Chapel Design Process 78

 Dining Hall Notes And Studies 81

 Dining Hall Design Process 84

 Housing Notes And Studies 86

 Housing Design Process 89

 Educational, Administrative
 And Library Notes 92

 Japanese Architecture Notes And Examples 94

 Bibliography 95

Reflections And Thanks 97

 Reflections 99

 Thanks 100

THESIS

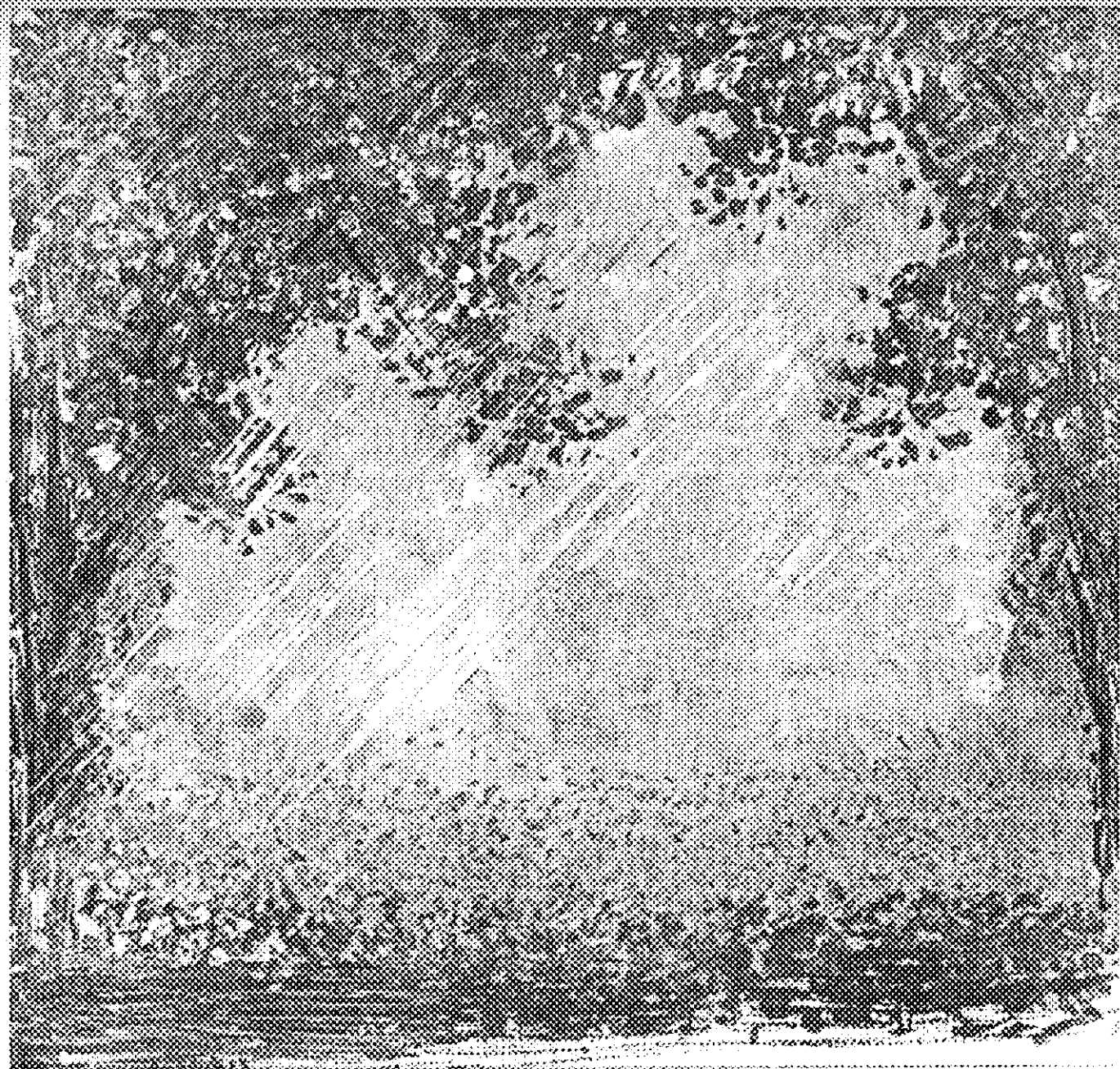

Throughout my six-plus years of architectural education, the following thoughts have repeatedly crossed my mind. Many times I find myself and others simply labeling or assuming a space as functioning in a particular way. We label them as gathering spaces, individual spaces, community spaces, spiritual, etc. without always considering the constructs necessary to spaces of these types. Initially, size, location, type of activities and uses within the space seem to be the main constructs (the tangibles) discussed or considered in design. Emotional qualities and perceptions (the intangibles) may be discussed or considered but are usually less successful in the final architectural design. Too often they become a "chance" type occurrence. I've seen this not only in my education but also in my professional career and reviews of other professionals' work. Too many times, the utilitarian or functional aspects are the basis or generators for the final design. Although they are important in a successful work, they should by no means be the complete answer to a problem.

Realizing that a physical space or detail cannot create a human spiritual experience, I feel it should still be used to influence those feelings. Physical and tangible elements can and should be used to help reinforce and enhance certain qualities through man's encounters with them. Man is an emotional and spiritual being thus he needs stimuli to nurture these qualities. Emotionality and spirituality are intangible and immaterial as well as subjective. This adds an increased challenge in appropriately reinforcing and enhancing them with the highly tangible, material and objective realities of the built structure. Objects, buildings and spatial types have symbolic and functional meanings assigned to them by man

through his traditional interactions with them. This is important to consider when dealing with these elements as design tools. They help to create the necessary balance and understanding man usually strives for in his life thus bringing him closer to a harmonious state with them. Although I also feel that giving him increased stimulations through reinterpretations, alternative ways of seeing things and possibly new ideas can help the individual to advance intellectually, spiritually and emotionally which is also a necessity of man who is not a static being. The user's intellectual, spiritual and emotional self can be altered by the latter through an increase in their life experiences. By giving them a new situation to interpret, they are able to confirm, correct or advance their perceptions, giving them something for comparison or testing. This will allow them to move closer to a higher level of meaning in their life if they use their perceptions appropriately. As was discussed earlier, I challenge that today's architecture is sufficiently stimulating man. We've been overly concerned with the utilitarian qualities of architecture for various reasons (too numerous to list) and have come to discuss the less tangible issues as tokens or "the first to go" type items, sometimes leaving them to chance or forgetting them altogether. The creation of "bland", ordinary and non-reinforcing environments which man simply tolerates rather than enjoys are the most certain result. This argument has lead me to make the following statement of my thesis intent. Even though architecture is composed of material and tangible mediums, it should still reinforce and enhance immaterial and intangible qualities, such as spirituality, at both the individual and community levels.

Definitions Of Spirituality

Before continuing, I feel it is important to discuss what I consider spirituality to be.

I believe the three definitions given by C.S. Lewis in the appendix of his book Miracles sums it up:

"Spiritual" is often used to mean simply the opposite of "bodily" or "material". Thus all that is immaterial in man (emotions, passions, memory, etc.) is often called "spiritual". It is very important to remember that what is "spiritual" in this sense is not necessarily good. There is nothing specially fine about the mere fact of immateriality. Immaterial things may, like material things, be good or bad or indifferent.

Some people use "spirit" to mean that relatively supernatural element which is given to every man at his creation -- the rational element. This is, I think, the most useful way of employing the word. Here again it is important to realise that what is "spiritual" is not necessarily good. A Spirit (in this sense) can be either the best or the worst of created things. It is because Man is (in this sense) a spiritual animal that he can become either a son of God or a devil.

Finally, Christian writers use "spirit" and "spiritual" to mean the life which arises in such rational beings when they voluntarily surrender to Divine grace and become sons of the Heavenly Father in Christ. It is in this sense, and in this sense alone, that the "spiritual" is always good.¹

In addition to Lewis' definitions, I find spirituality to be "anything not physically measurable but highly influenced by one's life experiences".

Emotions, attitudes and moods as well as general peace of mind and comfort are important in the spiritual being.

1. C. S. Lewis., Miracles (New York: Macmillan Publishing Co., 1960), p. 171.

DESIGN

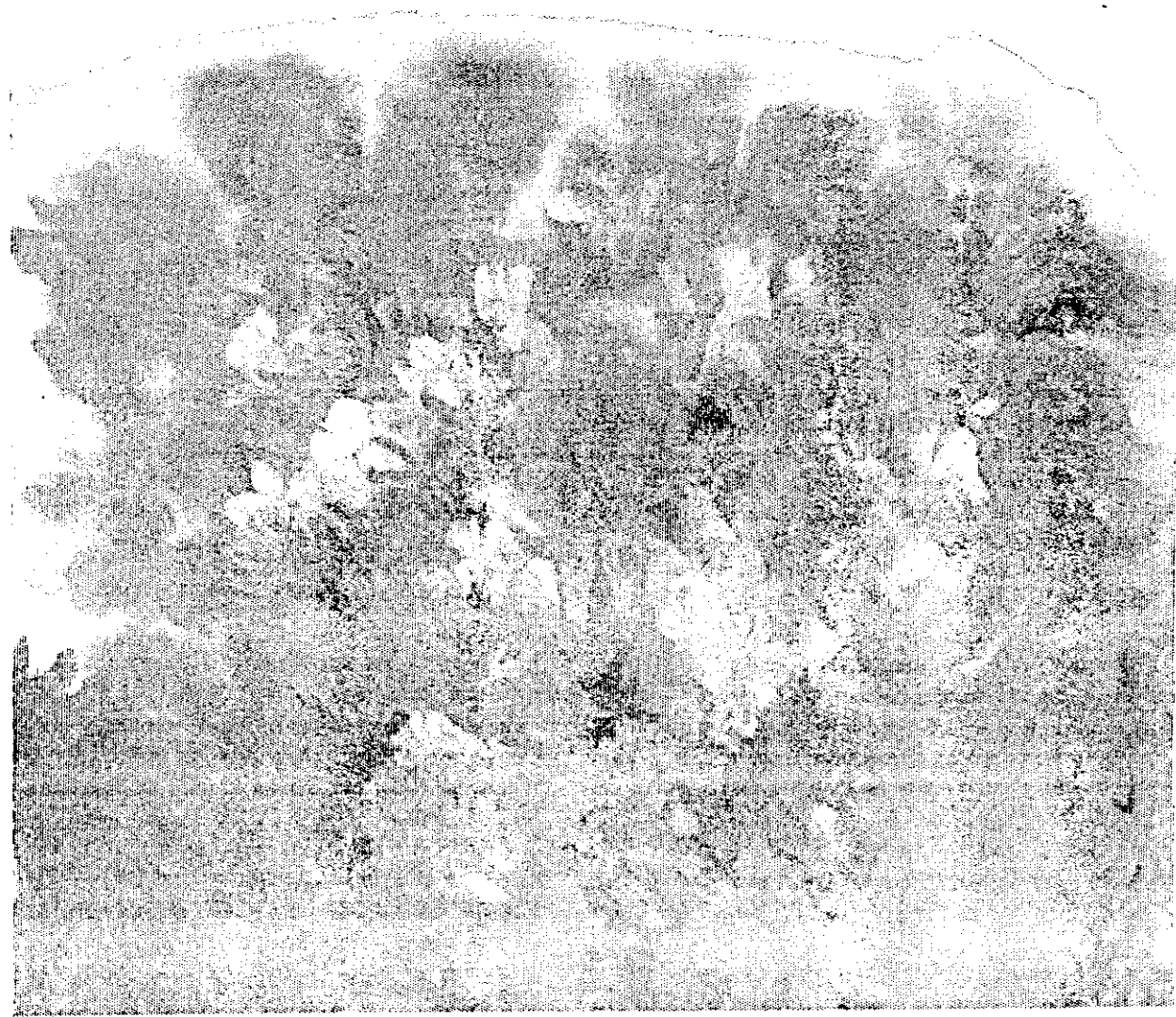

Project Description, Justifications
And User Identification

Even though I haven't defined spirituality as strictly a religious quality, I have chosen a highly religious environment with which to test my thesis. I chose to design a United Methodist seminary (protestant) for numerous reasons. It contains many different building types involving almost every aspect of one's life (work, play, education, eating, worship, etc.). It is a fairly unique type of environment in that the entire school revolves around the one central topic of religious education. Also, most of the activities in the environment deal with or are influenced by one's religion.

All of the users have a commitment to their faith in God and Jesus Christ and base their lives around this faith in order to find a peace for themselves and others on earth and the eventual reward of eternal life in heaven.

I believe the users of this community are striving for a higher meaning in their lives instead of the ones we often place too much emphasis on, such as a financial success, social acceptance, etc. A good comparison of a seminarian's goal might be similar to that of Abraham Maslow's "self-actualized" individual. His theory is based on a hierarchy of needs within an individual. Once their lower level needs are sufficiently satisfied such as physiological (food, water, etc.), safety (protection from harm), acceptance (being loved or belonging) and esteem (competence, usefulness, etc.) they are able to reach for a more highly motivated state in which they continually have a "...fresh appreciation for life. Even ordinary experiences - such as

a sunset, a casual workday or the touch of a child - can generate awe and pleasure."¹ Even though the seminarian may never reach this level of Maslow's hierarchy (as most people never do), they continue to reach for the ability to make good judgements, look objectively at others and accept them as they are, appreciate life to the fullest and grow personally. ²

Even though a person of this type already possesses the ability to be and grow spiritually I still feel that providing them with a stimulating environment can only further enhance and reinforce their experiences. Although a non-stimulating environment may be sufficient for a spiritual experience to occur, it may also cause non-reinforcing or negative distractions which could hinder any chances of personal growth. A further note about the seminary is that by being an educational environment, the users are generally more apt to be consciously aware of outside stimulation as they are in a period of heavy learning, searching and discovery.

I felt that due to its variety of uses, activities and its more consistently defined group of users, the seminary was a challenging and valid project for investigating my thesis. In addition, I have a personal interest in the project since a friend of mine is in a seminary. It also involved various building types which I had not previously had an opportunity to study.

I eventually designed a chapel, dormitory and dining hall as well as attempting a schematic campus master plan. The church is a building type I've always had strong feelings about as far as architectural design goes, while the dormitory and

dining hall were ones I've had close connections with. Having lived in various dormitories for my entire stay at Ball State University, I've developed a fairly high level of internal research on them through both personal observation and discussions with others. For this reason, I feel well qualified to design them.

-
1. Valerian J. Derlega and Louis H. Janda.,
Personal Adjustment; The Psychology of Everyday Life, 3rd Ed. (Illinois: Scott, Foresman & Co., 1986) pp. 12-15
 2. Derlega and Janda, p. 15

Site Choice

When first looking for a site I was faced with the dilemma of what it should possess. Should it be in a highly urban setting where I may be required to work within an existing man-made surrounding and totally create the environment within the site or should it be more rural in nature? Both had unique challenges associated with them so I approached it from a different direction. I questioned myself and others, including two ministers, as to which types of environment they have most often been moved by. The answers were overwhelmingly toward the natural site. Also, such states as seclusion, isolation, limited interaction, etc. of one within this type environment seemed to be the more preferable experiences.

This information made the selection much easier. My next step was to find a site. Due to my familiarity with a number of sites like this in my hometown of Osceola, Indiana, I selected an irregular shaped 70+ acres, approximately 1/2 mile East/West by 1/4 mile North/South, which included a beautiful winding creek, variety of contour changes, some open marshy land and a very dense wooded area covering most of the site (see site analysis in Appendix).

Even though this site (just recently converted to a county park) is bound by two highways, U.S. 33 to the South and Indiana 219 to the East, it still provides dense enough vegetation to adequately seclude one from many of the undesirable aspects attributed to the highways and surrounding environments.

Due to the site's size, it provided ample space and variety for both heavily built and secluded types of environments to occur. This allowed for a greater variety of experience types which is some-

thing I felt necessary when trying to appeal to large numbers of people. Also, various stories have told of Jesus going off by himself to some peaceful and secluded place to meditate and talk with God.

I personally feel closer to God in a natural environment since it is God's creation. Although man alters it greatly at times, he will never be able to totally control it. Time and nature are always more powerful due to their inherent dynamic power. It is always in a state of change so rarely will it become boring if left alone. This is definitely a positive to consider since the environment can potentially provide refreshing stimulation. I believe this site can, and does, possess these qualities.

Overall Design Approach

In each of the designs, the experiences of the individual became the biggest generating force of the designs instead of economics, spatial type requirements or other typical programming considerations.

Since man interacts with only a detail or portion of space at any one time, I felt an approach which dealt with that first might be more appropriate. How this idea is applied will be discussed further in a brief description of each design attempted. I am not totally defining a detail as the connection of pieces or decoration, etc. although they are and were very important. Rather, I am defining it as how anything which has interaction with something else, physical or not, is achieved. This includes man to building, building to nature, man to man, etc.

Before beginning any designs, I first made a quick comprehensive list of design topics, terms and constructs to be considered (see Appendix). Of these, scale, truth/honesty, repetition vs. non-repetition powers, mystery, lighting, revelation, aesthetics, etc. seemed to be among some of the more influential issues. For example, one of these - truth/honesty - played a very large part in nearly all of the designs. Since the site was very natural in origin, I found great pleasure in dealing with the truth/honesty idea. One can generally understand anything about nature through simple observation. Nothing in nature has been for the simple sake of show. The aesthetics are a by-product or kind of prize associated with very necessary elements in a plant or organism's design. I felt this should become an important issue to deal with in my designs, especially in the expression of the building's structure. Finding the inherent beauty or detail in the construction of a

building can provide much of the necessary stimulation needed to extend one's experience of a space. Many times we cover or decorate surfaces and details thus misrepresenting the way things actually are. Decoration becomes an applied element which is really a type of waste or "cover up" of a lacking of some sort. This might be better solved through a greater consciousness of the natural beauty and understandability of the structure's necessary components early in the design process.

This one issue, along with greater consciousness to the others, can only enhance and reinforce the individual's spirituality by providing him with the chance to discover understandable or challenging stimuli thus allowing him to find more meaning and enjoyment within them.

CAMPUS MASTER PLAN

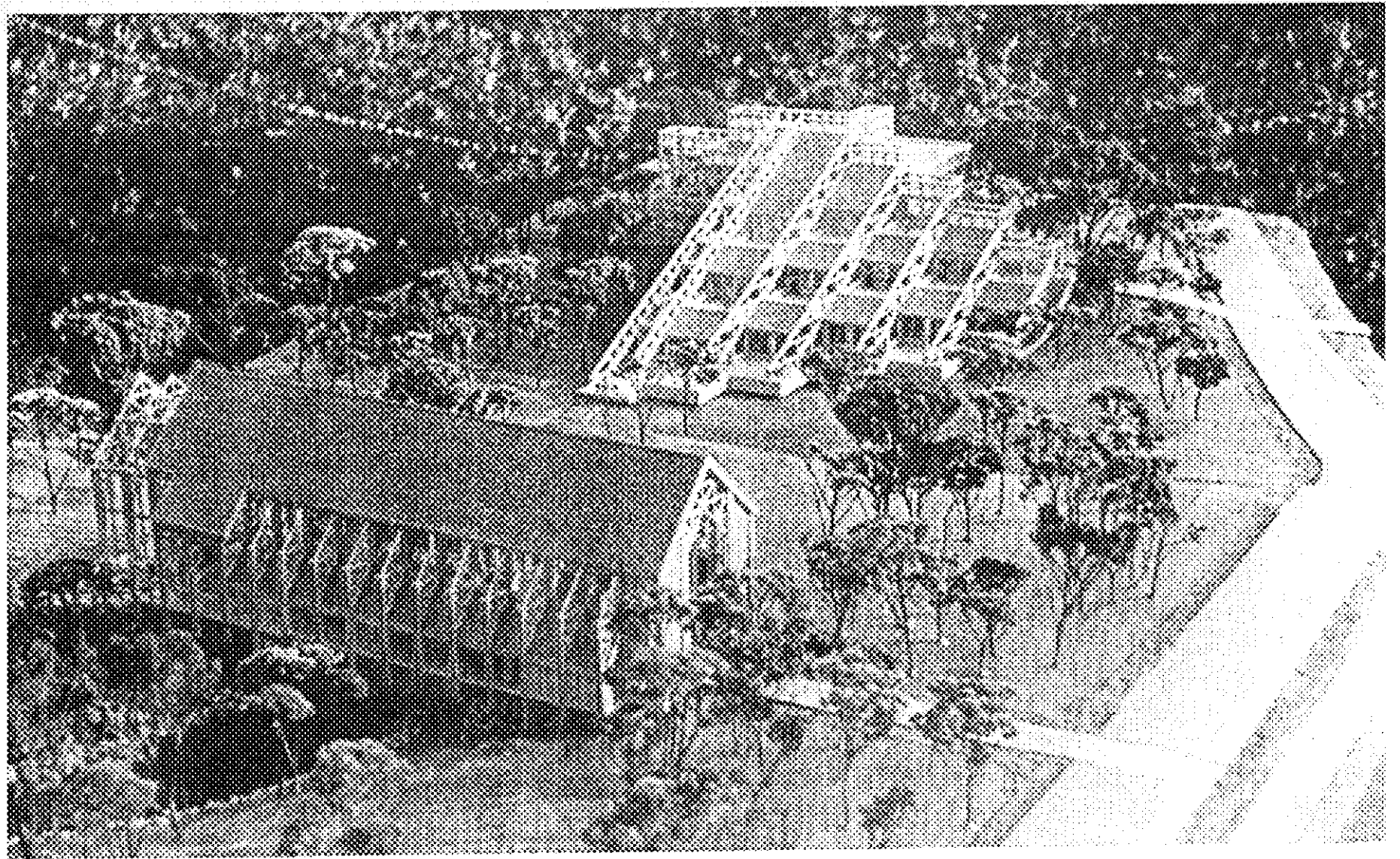

This is currently the most schematic of all the designs attempted. Many constructs considered in the design of nodes, paths, landmarks and subtle transitions from natural to manmade have been studied in the Appendix. Also included are some Japanese examples of these situations. Once again, the Japanese have used effective means in achieving spiritual and harmonious balances between man and his environment. Much precedence was collected and studies done to find an appropriate scheme to order the campus around (see Appendix). My search ranged from the very formal hierachical system to the organic nature-responsive design.

Realizing the powers of each, order in the formal and sympathy to the organic, I felt merging the two would create a more meaningful environment. Many powers are created in the plan, thus they may be hidden or subliminal in one's actual experience. This may cause a sense of mystery for the person to contemplate. The individual's understanding that there is the principle of order although not always apparent is much the same idea behind faith.

The less formal pathway layouts respond to natural formations, experience systems and view lines. These include building perspectives and imaginary sightlines such as that between the chapel and the Jesus/Peter (faith) sculpture in the pond.

The overall ordering system in the plan is a radial one from one point on the site. At first, I pondered whether it should be a more visible point, such as a tower or hill, or should it be more symbolic. I chose the symbolic since there was no justification to expend money on something with no functional purpose. Due to the land and vegetation configurations in the Osceola community, a tower would probably go unnoticed.

I chose the cross between the two altars of the chapel for my reference point. This seemed natural since the altars represent God's domain and the community revolves around the worship of Him.

Other things which influenced me and were considered in the site's design are those found in the various site analysis studies completed in the first quarter of my thesis work (see Appendix). Many of the findings help determine building locations and preservation zones in addition to actually influencing the building designs themselves.

I feel the site enhances and reinforces spirituality through its increased awareness of details leading to senses of mystery, revelation, aesthetics and sympathy to the natural environment.

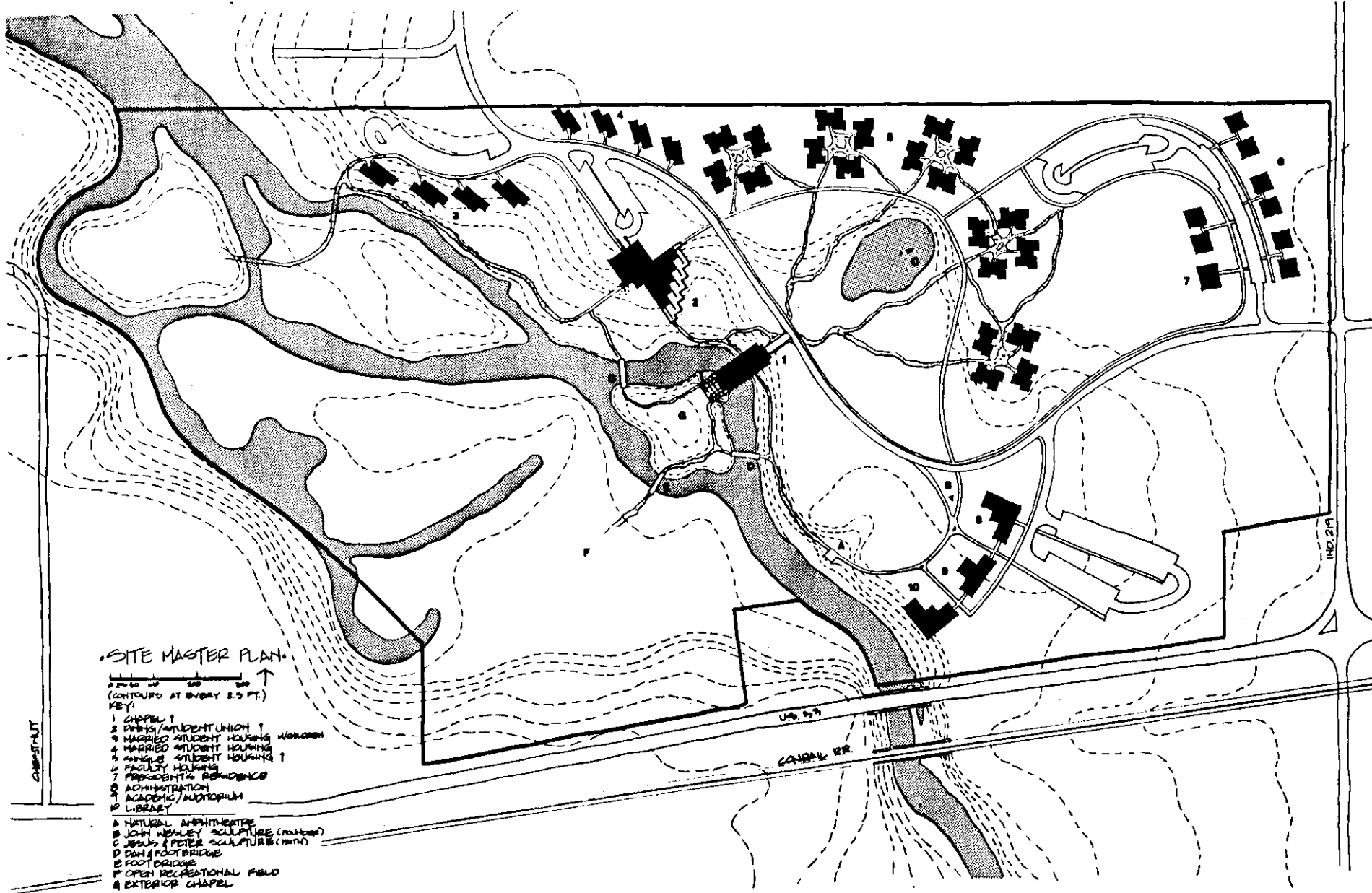

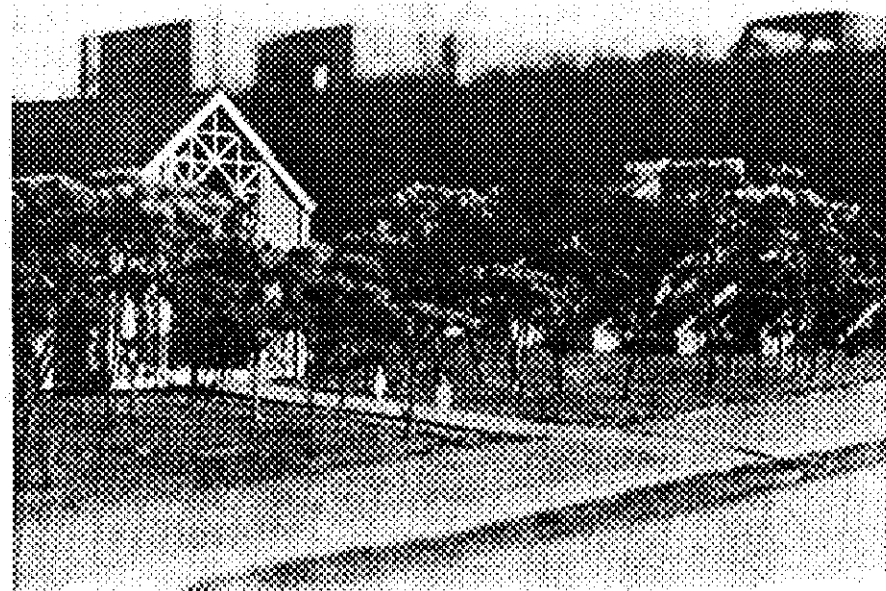
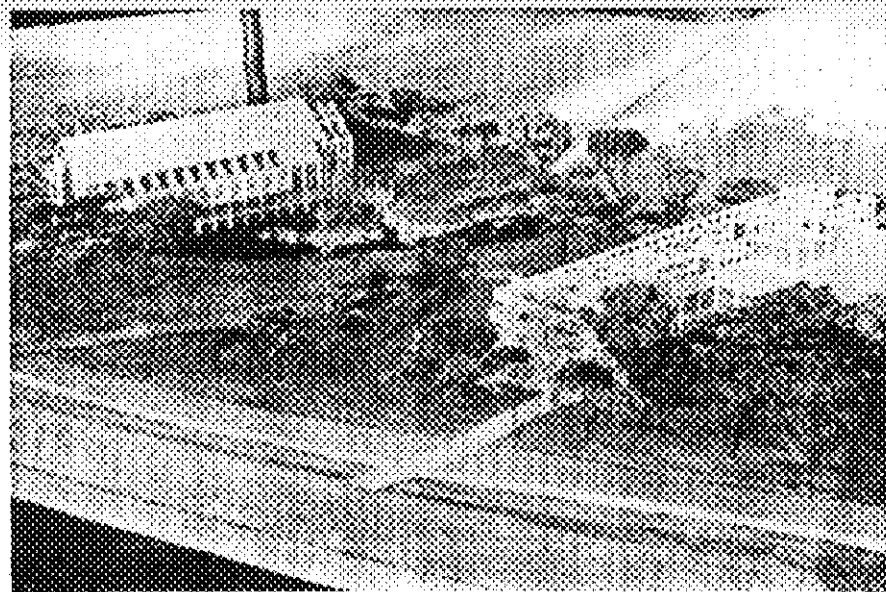

CHAPEL

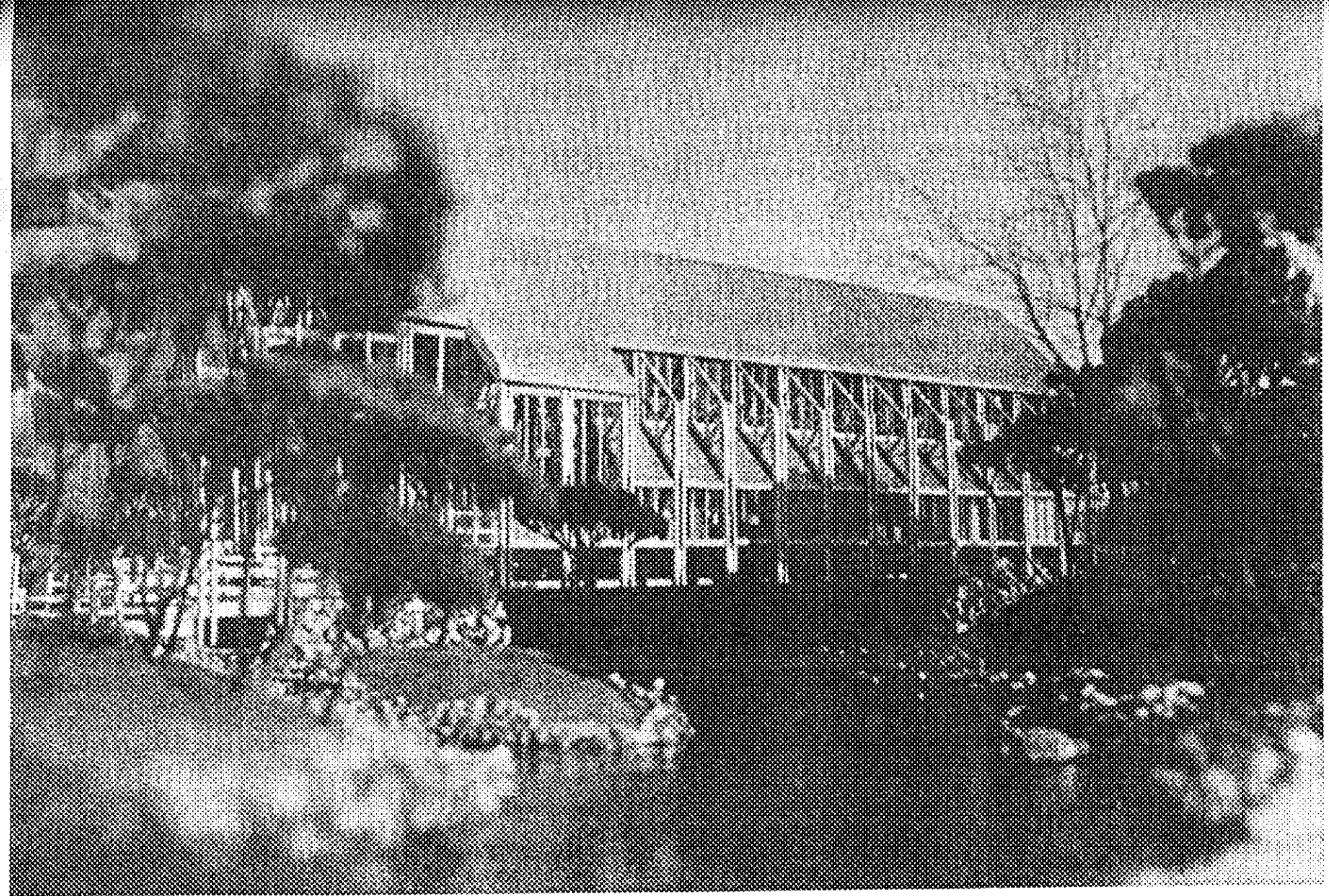

Chapel

Of the three structures I designed, this was the one building type I have the strongest convictions about. The chapel or church has traditionally been one of the most recognizable building types in the landscape. It has also been one of the grandest and elegant building types to deal with. However, today I feel we have been regressing in the designs of these buildings which are intended to represent the home of and our gift to a higher power, our God and Creator. Certainly, economics and the belief that extravagance is not a necessity or desire for worship should be considered during the design process. However, should these buildings be less elegant or costly than the living room in our own home? That seems to be the direction we are heading. I realize most churches do the best with what assets they have. I think that with a closer look at some of the construction techniques we use, rather than thinking strictly in conventional terms, we may be able to discover some alternative construction possibilities at little or no extra cost. This would still leave the necessary funds for missions and other church obligations. Also, a concentration on more permanent or higher quality materials may reduce the cost of repairs and upkeep.

Many things can play a part in the design of a chapel such as symbolism, truth and honesty and the expression of the church's construction. I have dealt with these and many other of the constructs discussed in the appendix in my design of the chapel. The overriding concept of a bridge was inspired by the story in the bible of Jesus walking across the water with Peter following him. As long as Peter focused on Jesus and had faith in him, he was okay but as soon as he looked away, he began to sink. This theme is also represented in a sculpture in the center of the pond on line with

the chapel's main axis. In addition to this, throughout the bible man has many times had to perform some physical task involving nature in order to become closer to God, i.e. climb a mountain. Thus, I feel the crossing of the creek is appropriate. The altars of the chapels occupy a small island representing God's domain while the narthex on the other side of the creek represents man's. The nave is a bridge which serves as the connection between the two. I have incorporated water for many uses other than the Jesus/Peter example. Due to its significance as a purifier (baptism) and a source of life, I've highlighted its use with fountains, waterfalls, streams and ponds throughout the chapel and campus plans. Other symbolic references such as numerology were considered as additional features in the design of the chapel. The numbers 1, 3, 4, 7, 10 and 12 have important significance throughout the bible. An example of this would be the three steps leading to the altar which represent our Triune God.

One additional area I investigated was the consideration of traditional forms and those forms indigenous to religious architecture and the local region. I looked at the gothic cathedrals of Europe for their powerful qualities attributed to scale, procession, lighting, sense of mystery, etc. which helped in the discovery of the basilican plan and section. I felt this was an appropriate form due to its organizational powers, however, the use of heavy stone construction would not fit properly with the rest of the campus's theme. I then turned to studying some of the farm architecture and covered bridges of Indiana in order to find a more appropriate construction type. The dilemma of merging the basilican form and the heavy timber construction system was not as difficult as first thought since variations of it had already been used throughout many barns and bridges. I devised a scheme as seen in the building's cross section

which uses timber trusses and columns for the structure. With a reinterpretation of the column's function, I elected to use four vertical members of a smaller dimension to support the load normally requiring a larger column. This allowed for other structural members to pass both directions through the column thus simplifying some otherwise costly connections. Another benefit of this column was that I was able to increase the number of visual, vertical lines or edges seen within the column. This was similar to the fluting on the columns of the cathedral and helped accentuate the verticality within the chapel.

There is also the addition of an exterior chapel within the scheme. Its altar and that of the other chapel are opposite each other with a crucifix occupying the structural bay connecting the two. The exterior chapel is set in a natural environment with the seating being nestled in the wooded site. I see it as being a much less formal organization with the seating on natural elements such as rocks, logs or the ground with the possibility of providing temporary seating on chairs. I feel worship in a such a setting could be quite effective due to its physical attributes such as the sounds, cool breeze and warmth of the sun.

The last main design concern to be discussed is the chapel's lightweight feel. I believe this is necessary to create the least imposition on the landscape. One can view directly through the chapel from nearly any direction thus I feel it becomes an integral part of the landscape rather than destroying it. This also benefits the design in that it increases the light infiltration into the chapel giving it a warm natural feeling inside.

As has been described in the previous paragraphs, reinterpretations as well as a concentration on simple details can only help in enhancing and

reinforcing one's spiritual experiences. It gives them an increased awareness of elements in their environment which previously may have been overlooked due to familiarity. It also provides them with a warm, comfortable and aesthetically pleasing place to worship and meditate.

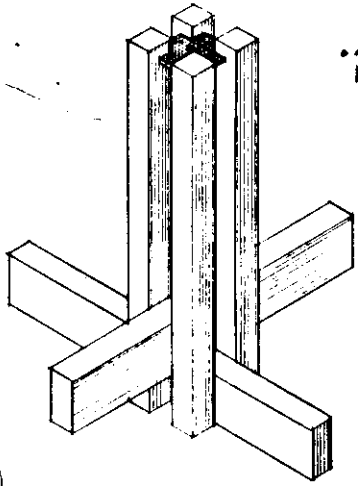

• SCHEMATIC COLUMN
DETAIL (NO SCALE)

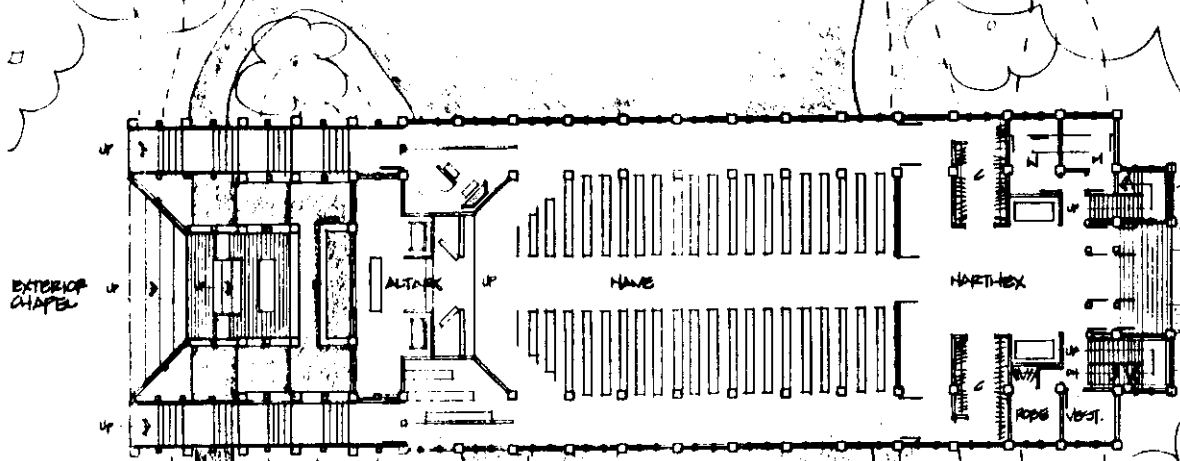
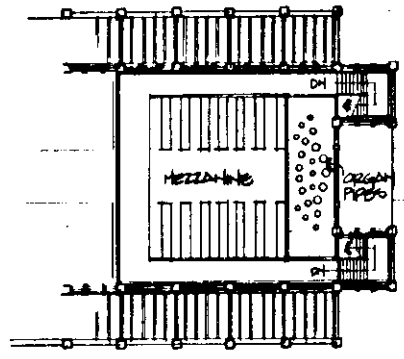

• CHAPEL PLANS •
0 1 2 3 4 5 6 7 8 9 10
↑

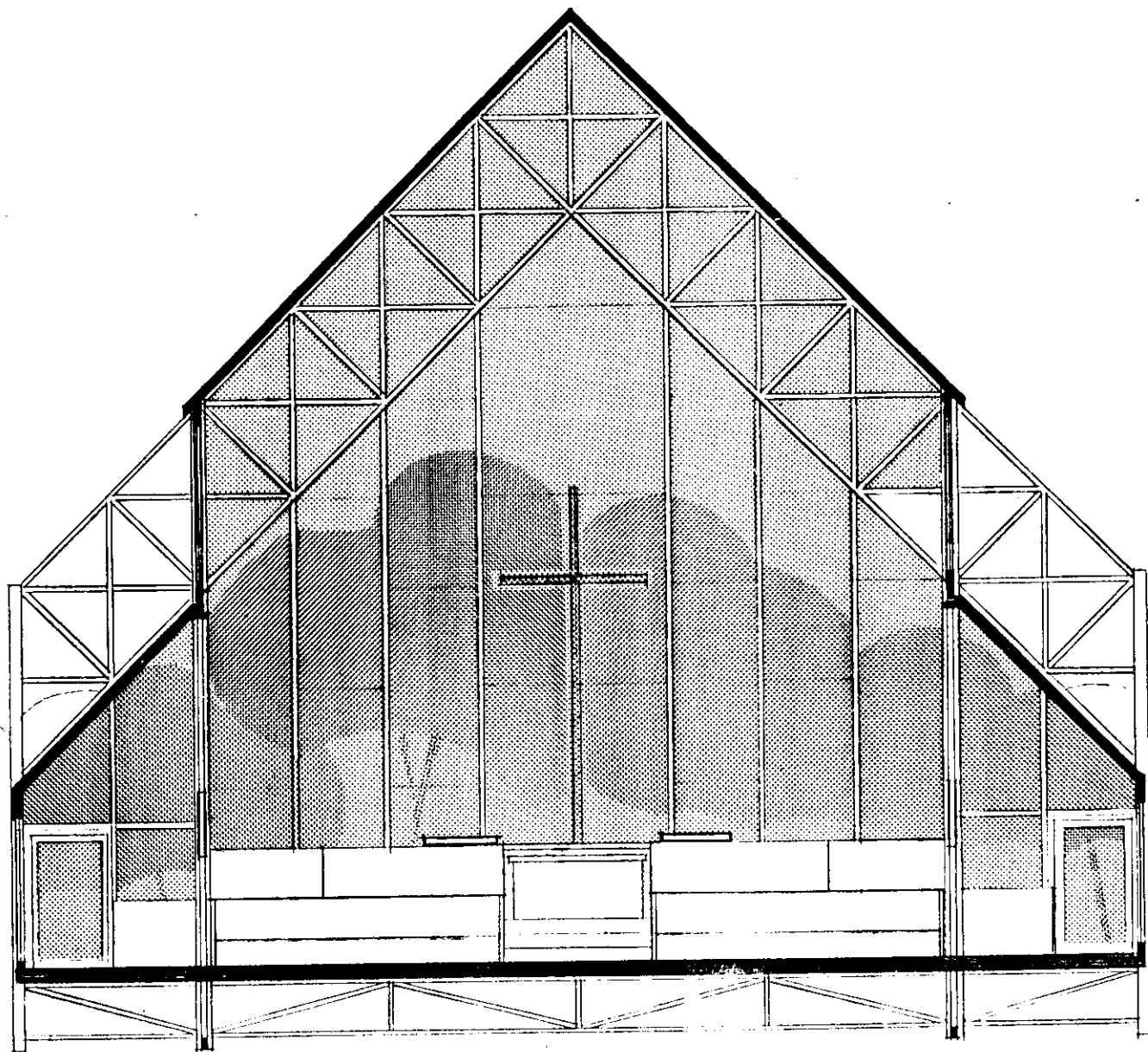

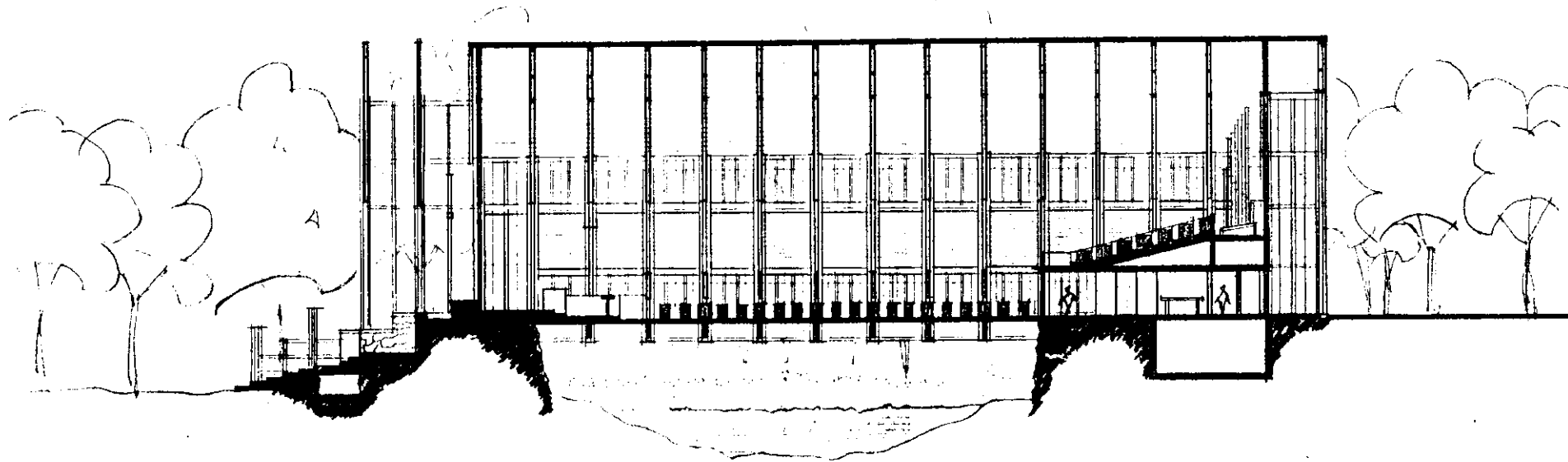
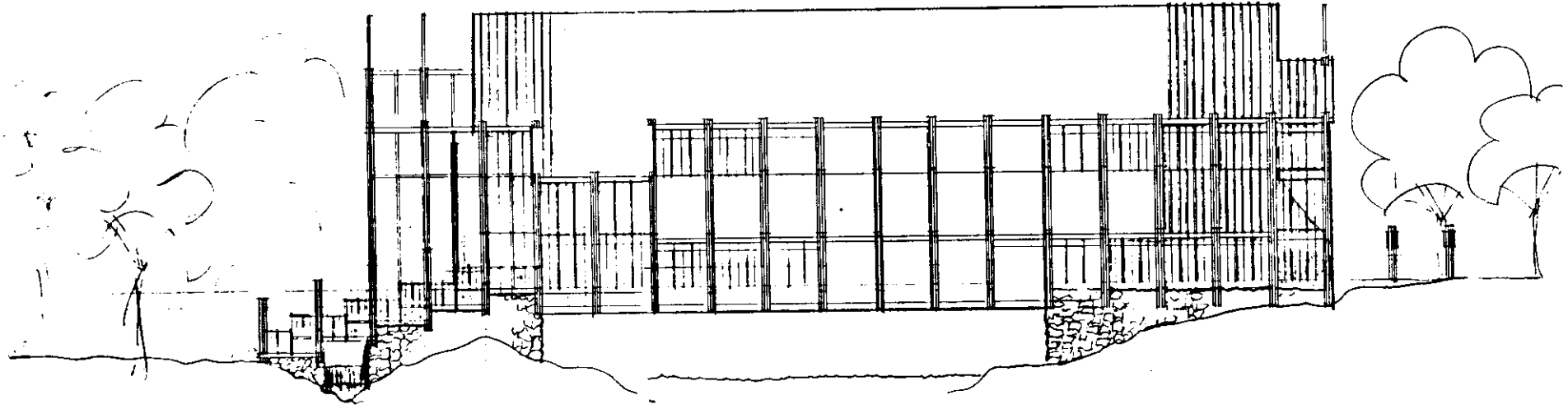

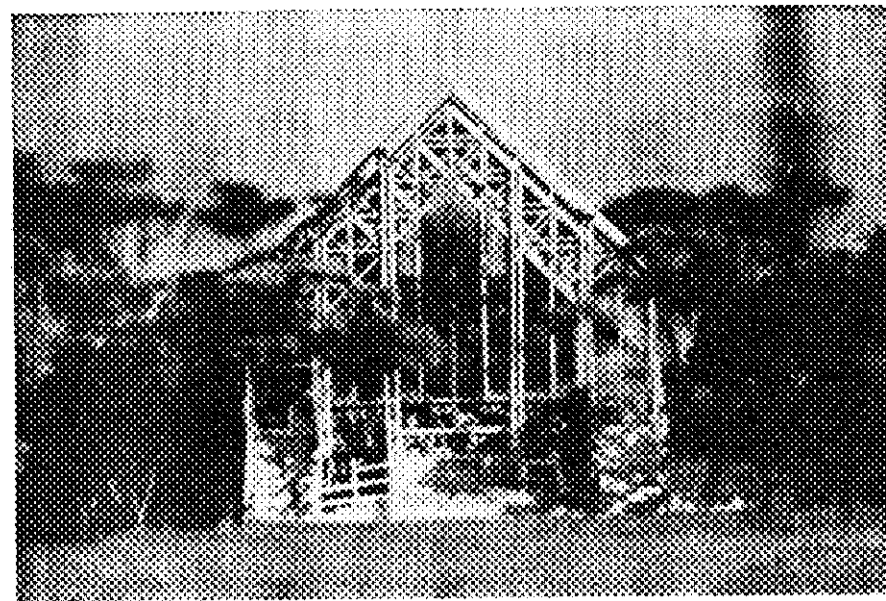
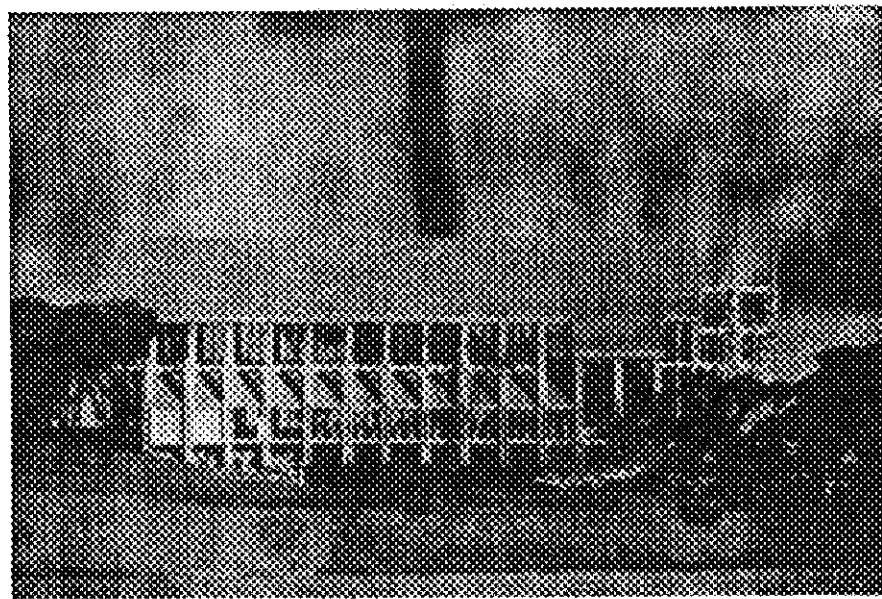
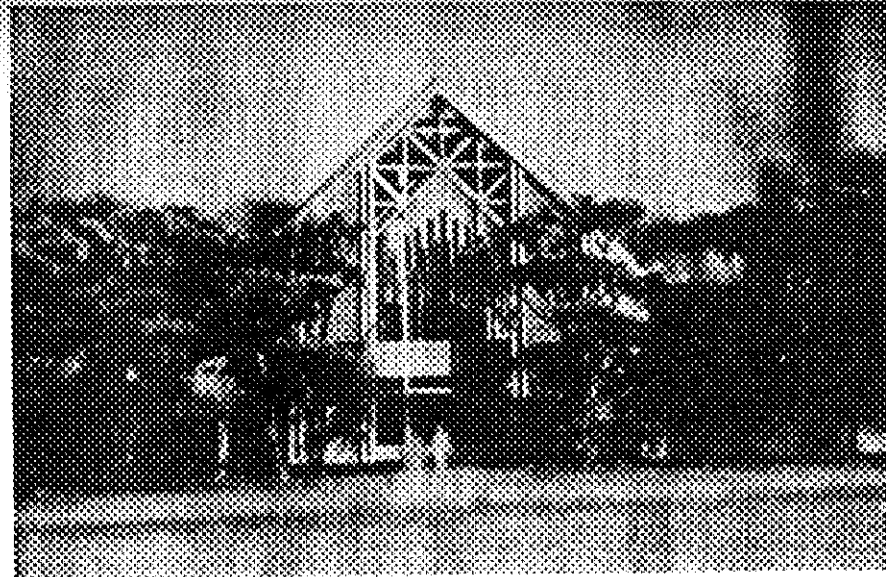
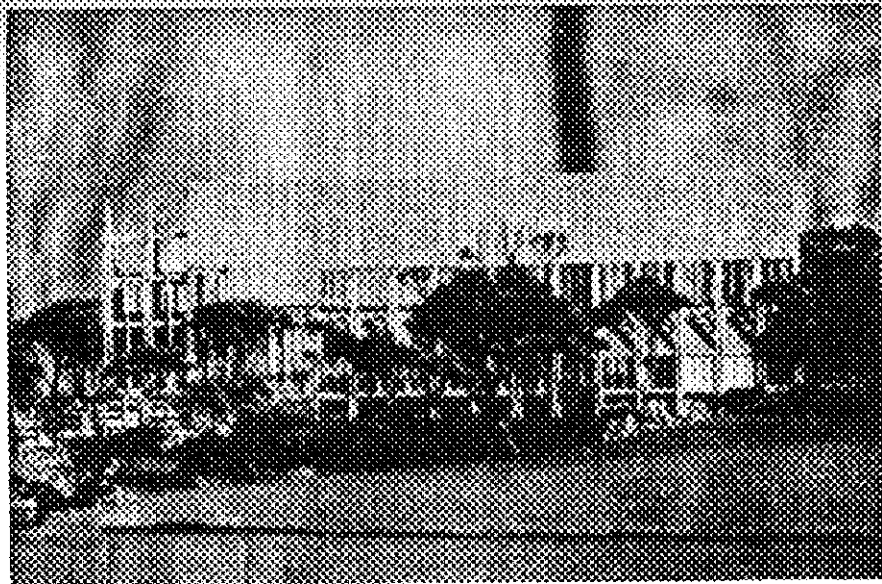

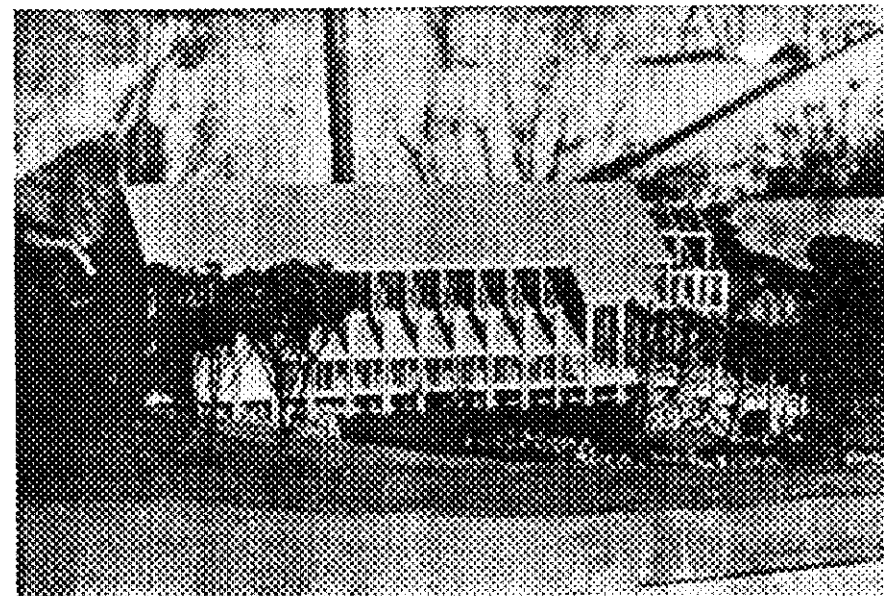
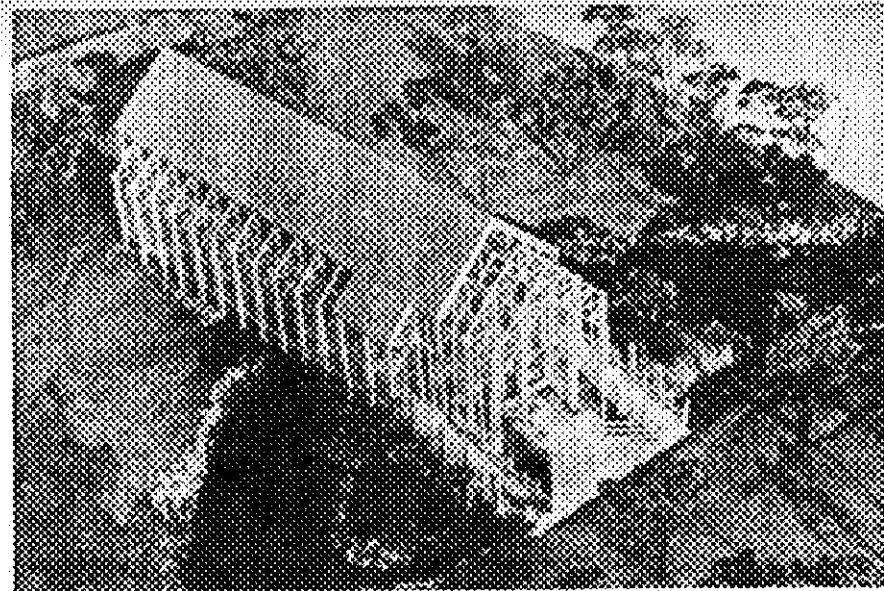
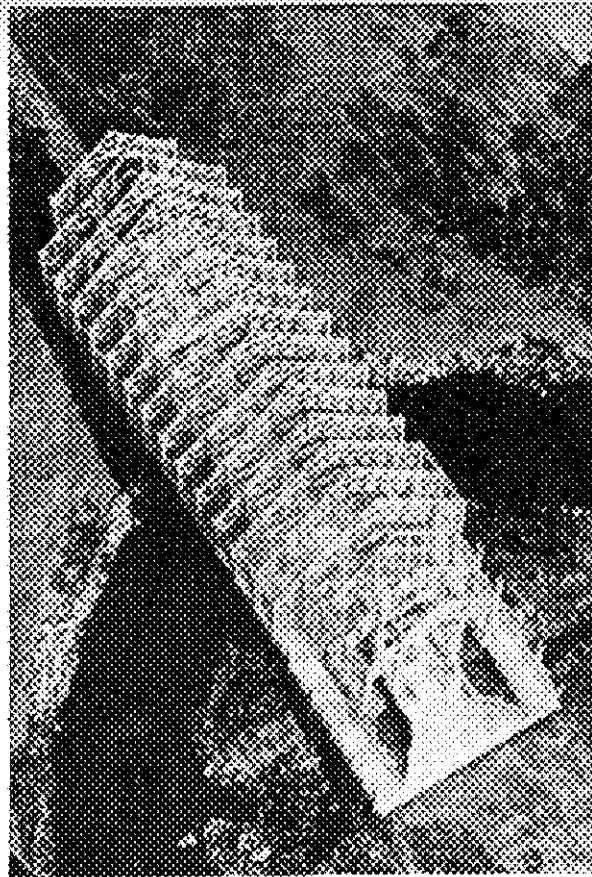

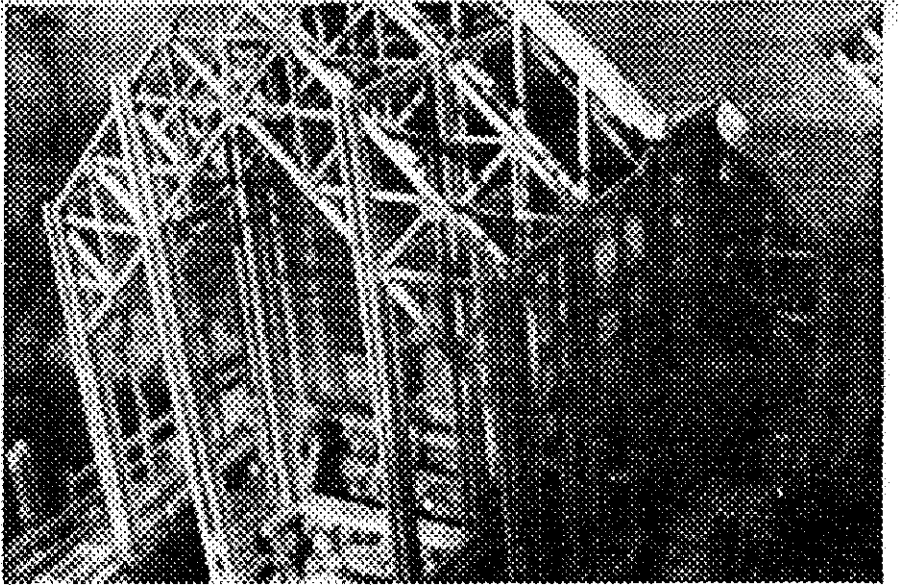
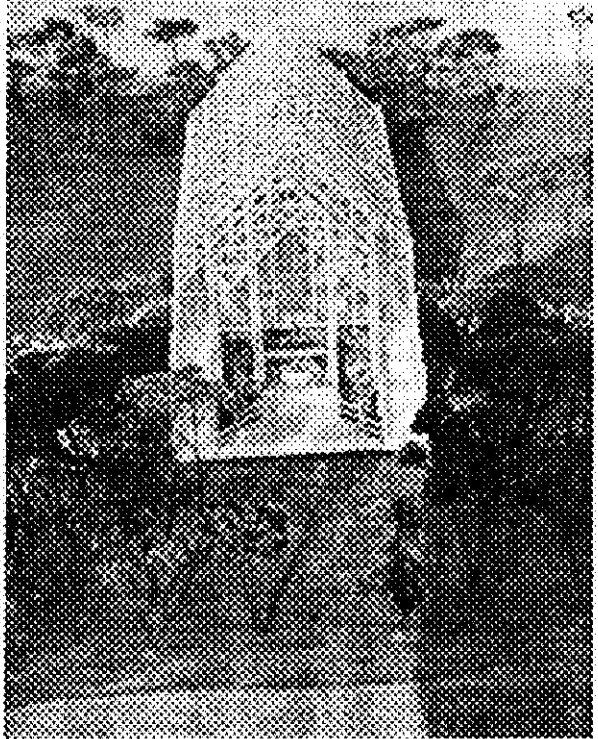

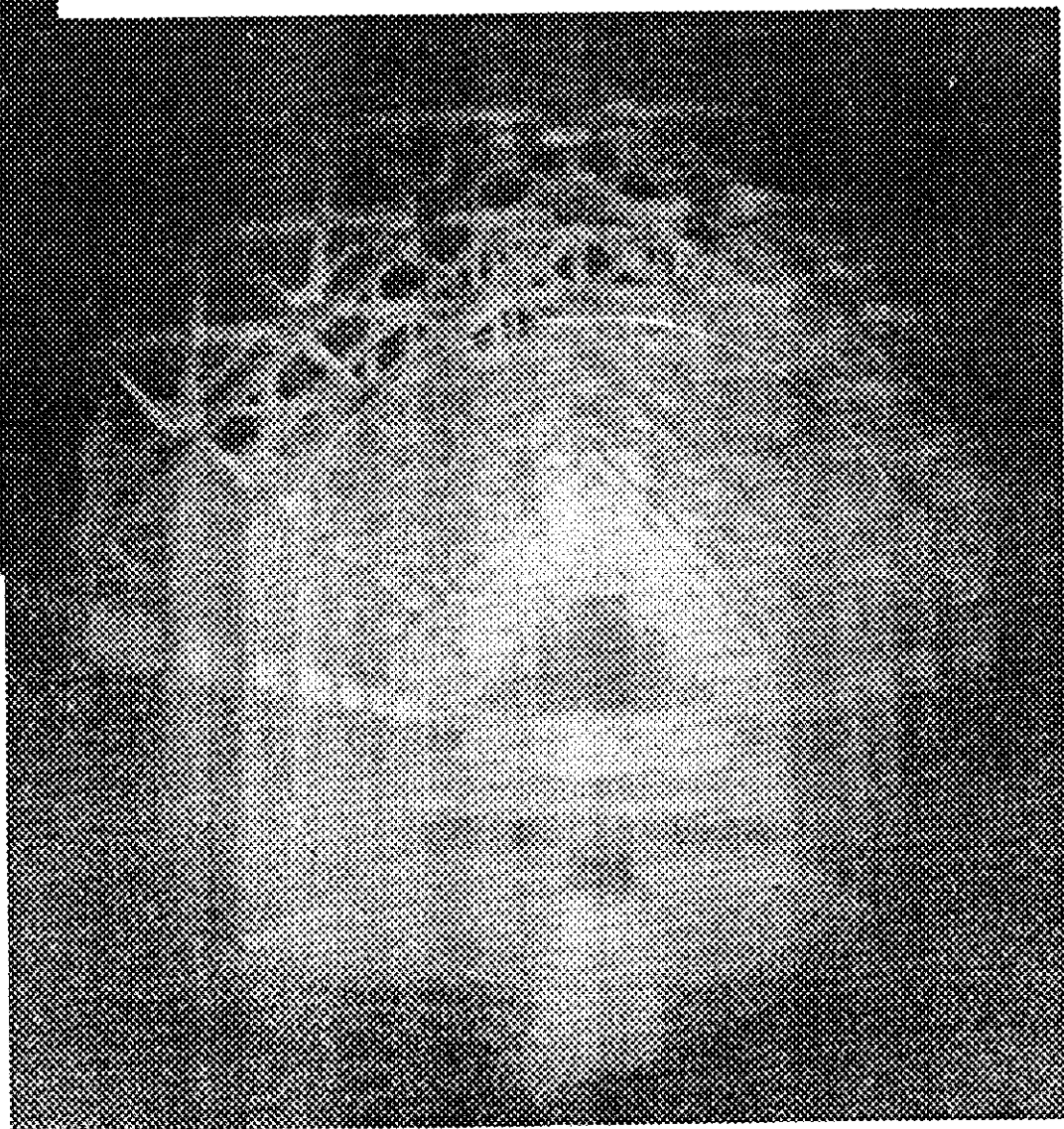
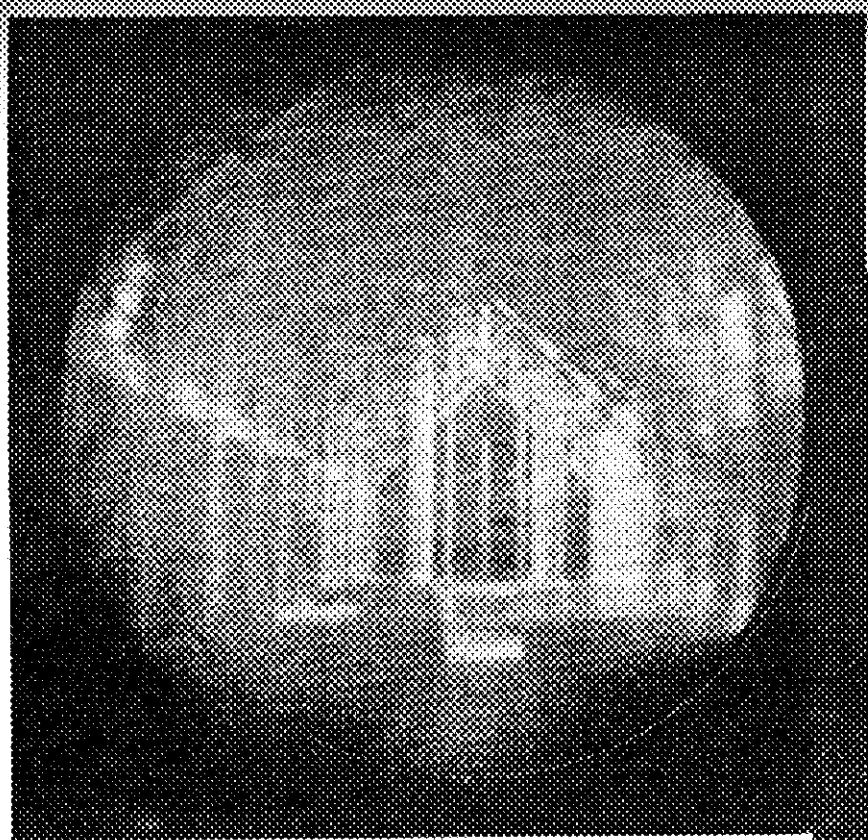

DINING HALL/STUDENT UNION

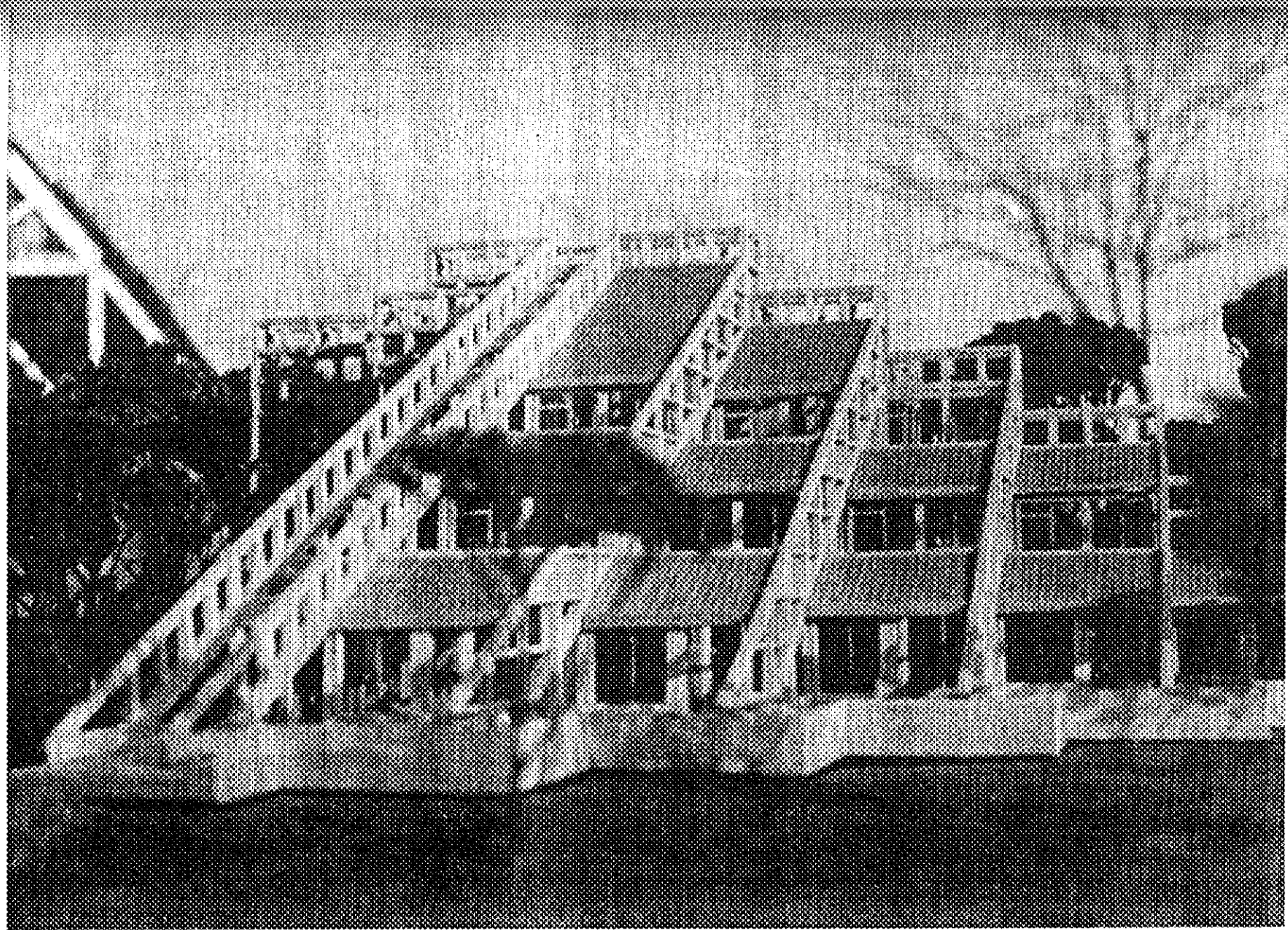

Dining Hall/Student Union

This building was unique in that it was a place in which the entire seminary could be drawn together in fellowship on a number of occasions throughout the week. The eating areas of the Snack Bar, Banquet and especially the Dining Hall were the spaces given the most attention. This space must be large enough to accommodate 300 or more people comfortably during common meals as well as be a rewarding experience during the times when only one individual is dining. In order to design for these situations, I had to first look at the rituals and consciousness of a user in each. Through my study involving both observations and discussions, I determined that an individual was more conscious of activities at, or within, a table setting during peak times or with a group. While the individual appeared to be more environmentally conscious at those times when he was alone or with a few others within the hall, the latter was particularly detrimental when the person didn't choose to be alone. In this situation, an environment with dozens of empty tables and chairs could be very harsh or isolating.

When designing for this problem, I looked at a wide array of physical spatial qualities such as scale, plan and section configurations, interior/exterior interactions, circulation patterns and many others which might enhance the comfort of one's visit. In addition to the previously defined zones for the various type activities, using more ambiguous details such as the openings in the ceiling for added light, floor to floor interaction, visual interest and increased spatial scale at or near areas of greater density further heighten one's experience through a more appropriate setting. I designed the small serrated side of the Dining Hall for mostly individual use. The size of each serration is sufficient for the comfortable place-

ment of one table. Being adjacent to the exterior on their East and South sides, they create a breakfast nook type setting where the individual can sit and view outside. This is a better experience than sitting in the middle of empty tables which only reinforces loneliness.

Both the building form and timber truss construction were in response to their setting. The sloping and stepping form of the dining area responds to the existing hillside and depression. Since these land forms would receive slight alterations during construction, I felt the building should at least symbolically recreate them.

The trusses and open timber wall construction not only provided a simple structural system, it also gave the building a lighter and delicate feel similar to that of the surrounding wooded setting. The honesty of the expressed structure helps one further understand and appreciate the building and its inherent details. It was inspired by the truth and honesty expressed in nature as was discussed earlier in the entry on overall design ideas.

Lastly, I believe the variety of concerns addressed and the details included in the Dining Hall/Student Union help the building read as being very active which is appropriate in a community structure of this type.

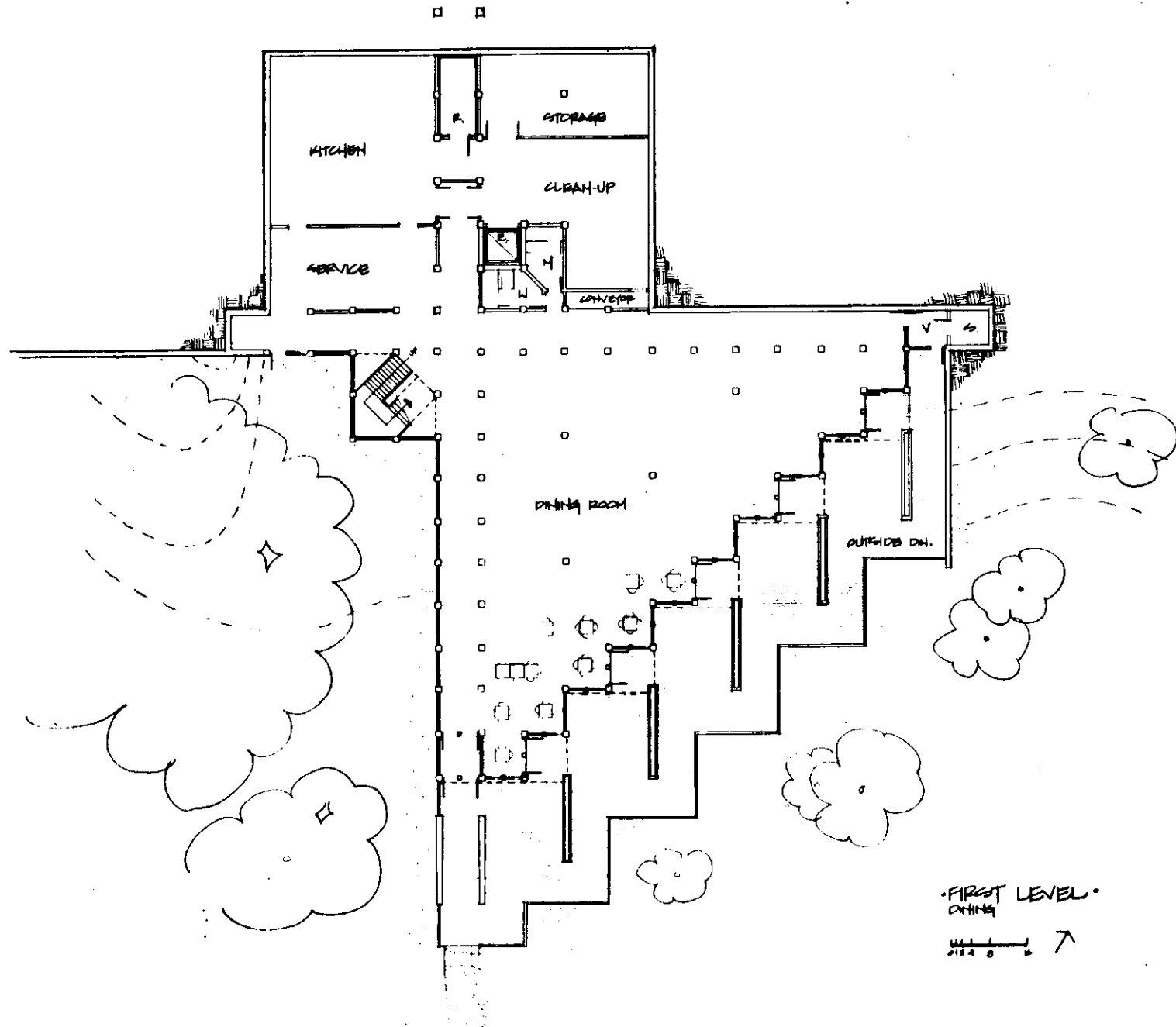

• FIRST LEVEL •
DINING

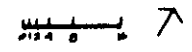

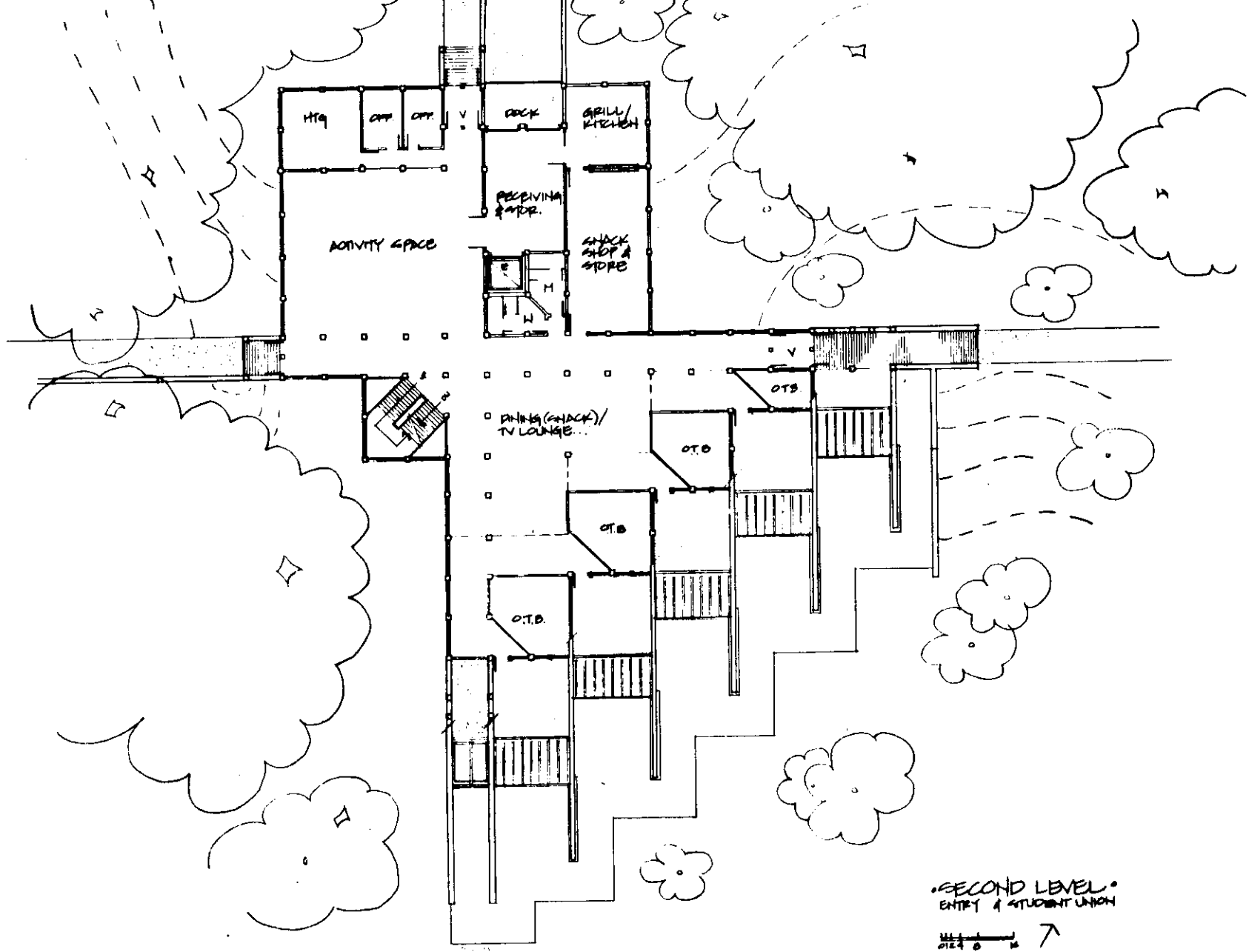

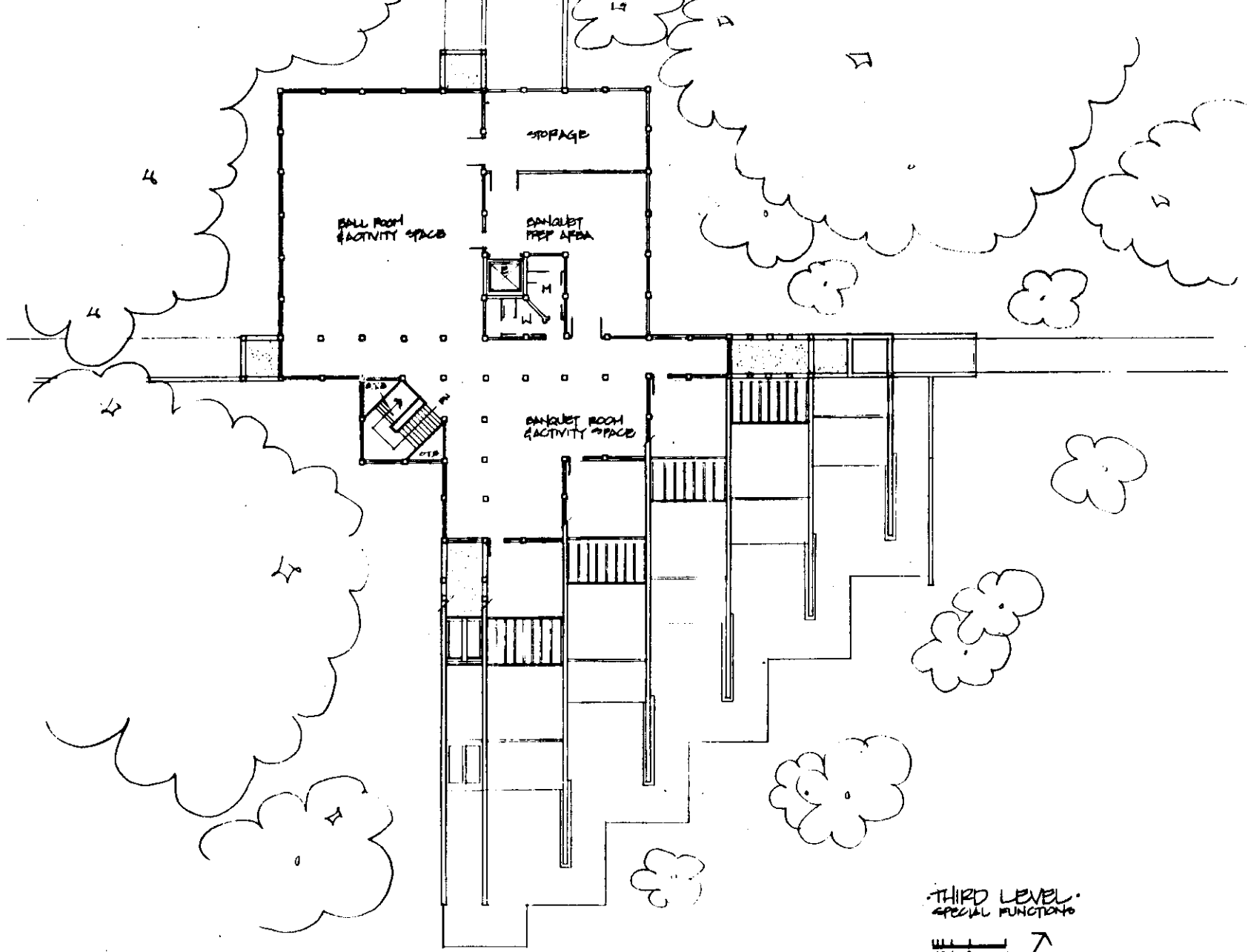

THIRD LEVEL
SPECIAL FUNCTIONS

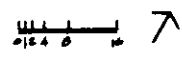

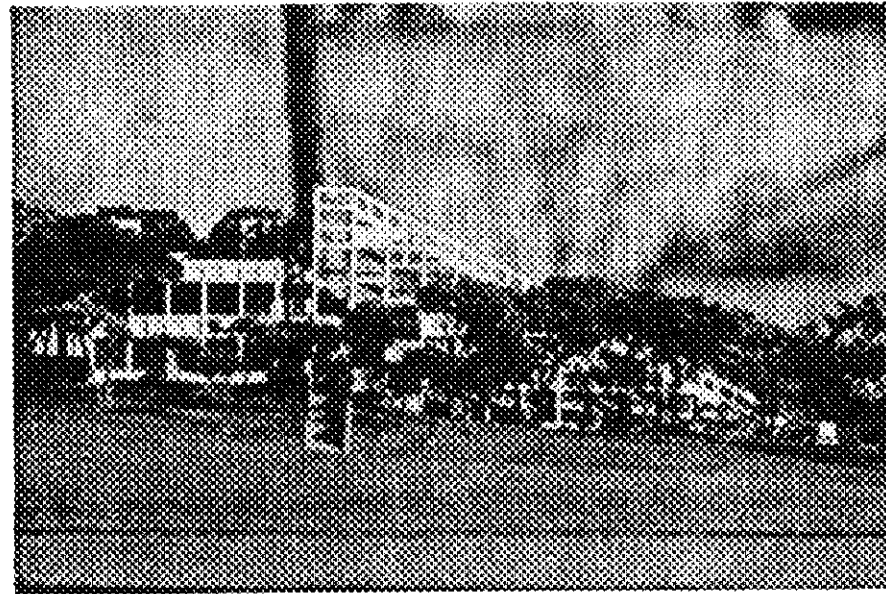
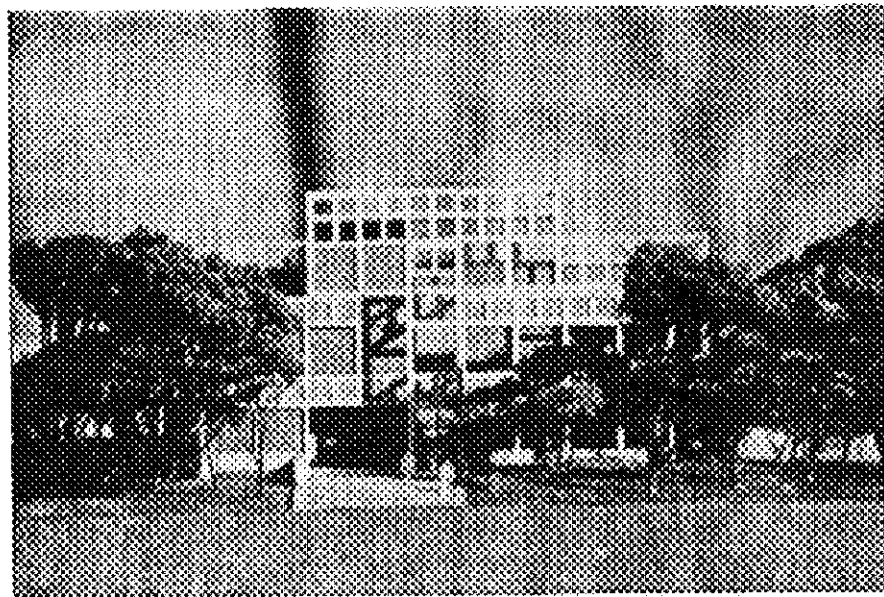
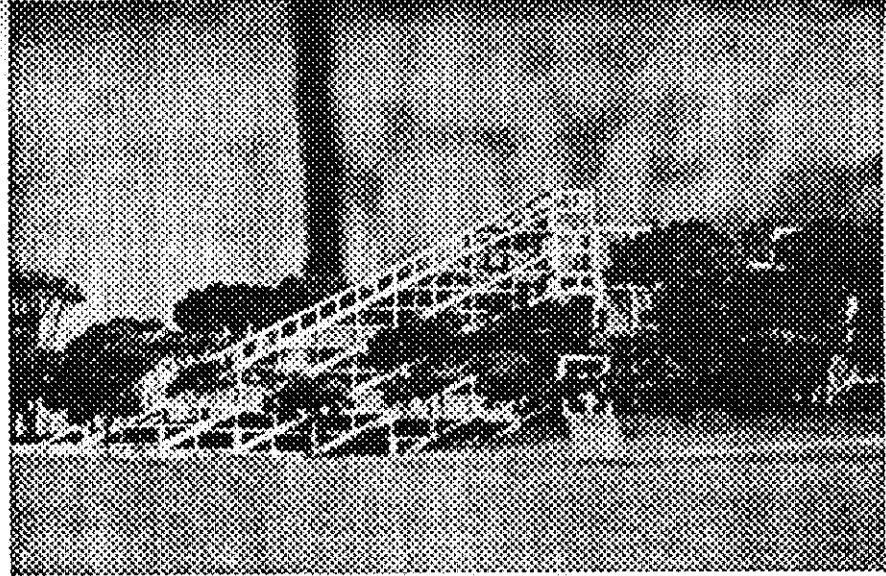
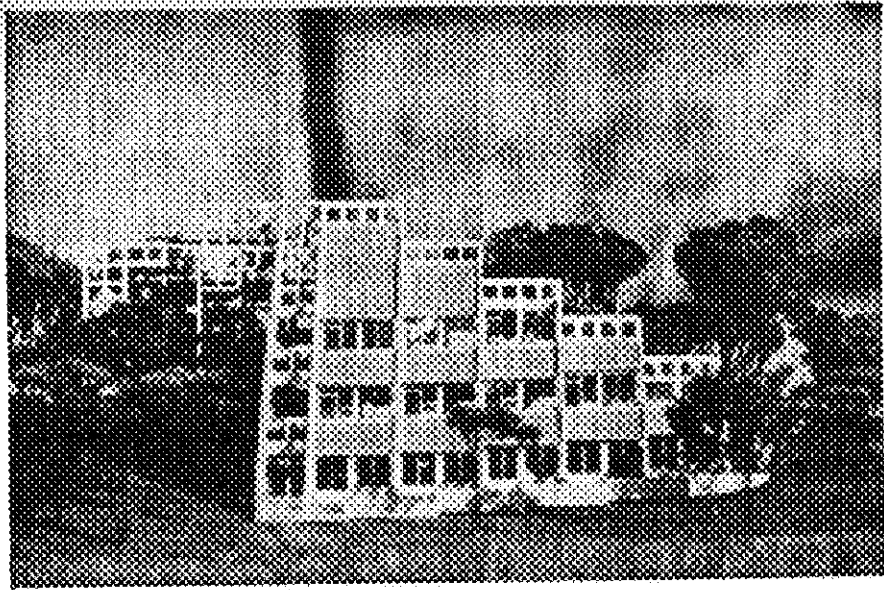

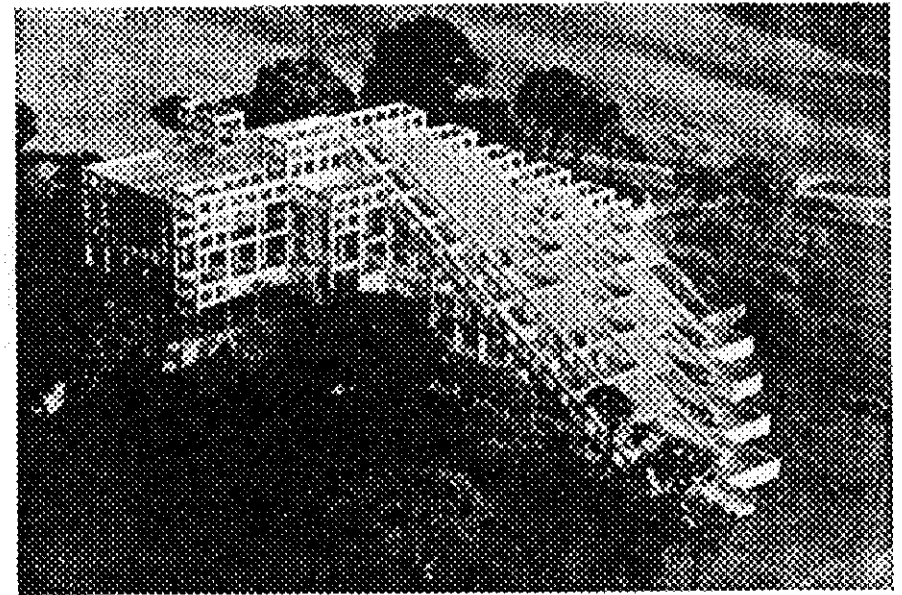
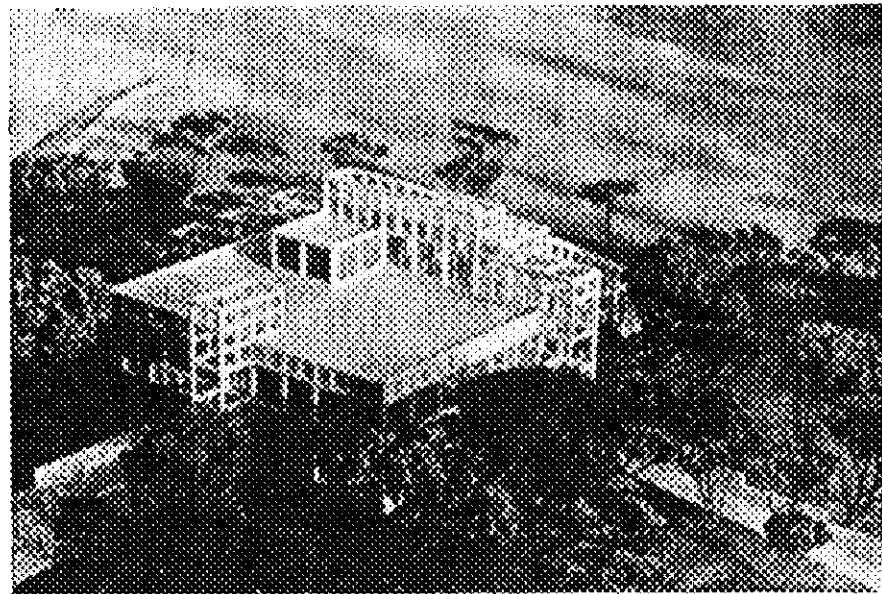
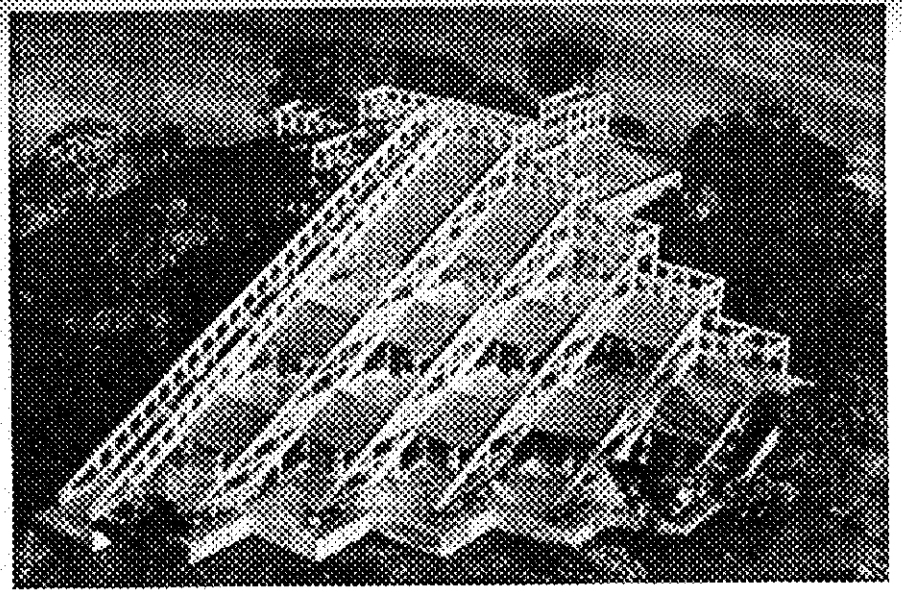
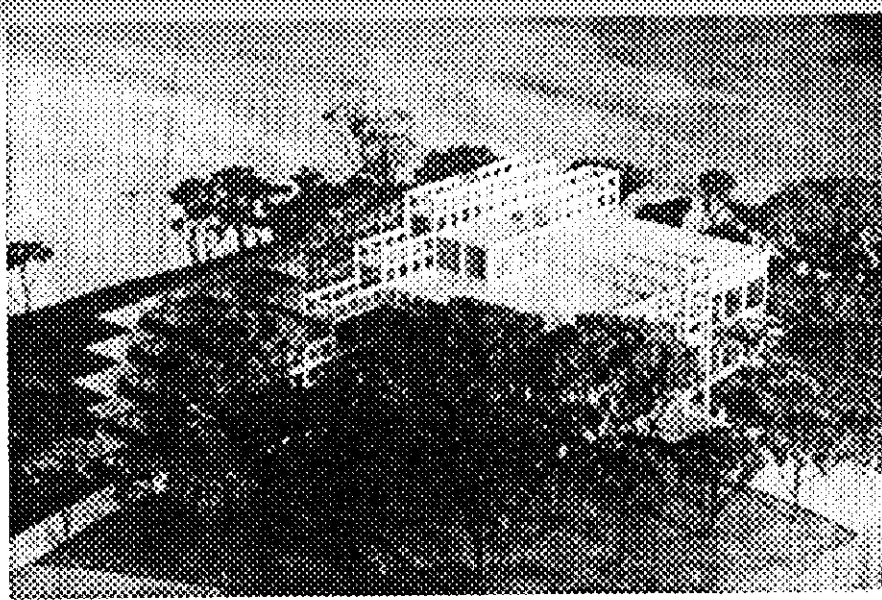

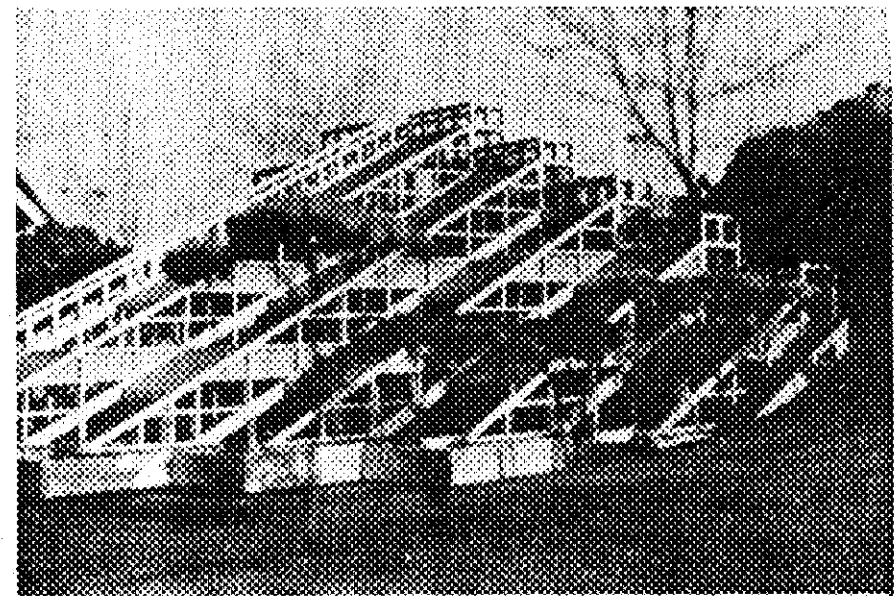
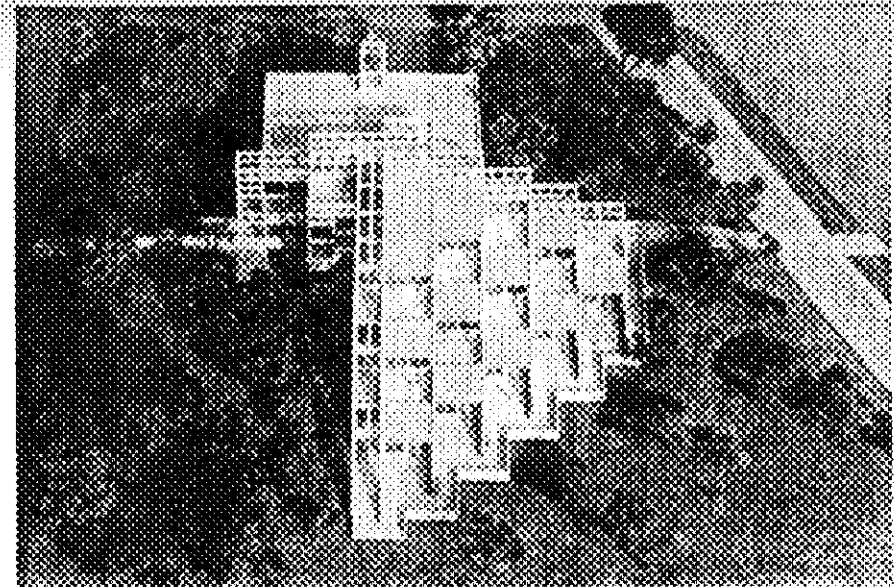

SINGLE STUDENT HOUSING



Single Student Housing

The single student housing was one of the most important building types to study when considering the spiritual environment. I saw it as dealing with the most private and individual aspects of the seminarian's life. Aside from the sleeping, studying and limited entertaining functions of the individual rooms, the housing has to provide an environment conducive to meditation and personal reflections. Identity also plays an important part in this environment. The person should be able to identify with a space through his personalization of it as well as the spaces initial attributes. The person also needs to identify or affiliate with a group at many levels, i.e. family, peers, community, etc.

From the onset, the environment should be a warm, friendly and comfortable one as opposed to some of the more dehumanizing cold and forbidding ones which exist in many of today's more institutionalized examples. This is the student's home, a place to be proud of and receptive rather than resistant to.

I first determined that an individual should be provided with a private space in which he could control who enters and who doesn't. A place to retreat to and have control of as Christopher Alexander says in his book Pattern Language, "A Room Of One's Own" provides the individual a chance to get away without any possible distraction from others including a roommate. He stated that even though the roommate provides companionship, he can also become a distraction at times. The individual may become resistive or impervious to him in order to gain the necessary mental isolation. The greatest harm is that he may end up carrying this out into the environment as well, thus harming his social connections.₁

Even though there is a necessity for isolated situations, people also need some close intimate relations with a select few people and to associate with a close group "family". I've achieved this breakdown of social contact types within the housing scheme in the following fashion:

First, I provided the individual with his own room (private, controllable), he and another share a common wing including a bath (companion). There are four rooms (two wings of two) on each floor and eight rooms per unit house (family). Each of these unit houses includes a common kitchenette, laundry, library and living/entertaining area, much like a real home. Each unit house is part of a cluster of four (32 people total) which share a common entry courtyard. These clusters could be described as a neighborhood. At the current time, there are five neighborhood clusters, all connected by a common pathway leading to the dining hall and academic complex at each of its ends. This forms a community-type setting.

Returning to the individual room, I will discuss some of the various design ideas used to enhance the spatial qualities. First, the "L" shaped interior plan helps to inherently define zones within the multi-use rooms (study, sleep, entertain). The structure is a modular type system (see plans) inspired by Japanese architecture. The system is designed to allow for the maximum positive interaction with the exterior environment and is made possible by the ability to vary window and wall locations during construction. With no additional construction or cost, each of the 160 rooms can be created to take the best advantage of views, light, etc., especially with no less than three walls being all or partially exposed to the exterior. This is also an aid in ventilation, Due to the site's wonderful qualities (as described in

Site Selection), this can only enhance or reinforce the spiritual qualities of a space. This is unlike most dorms where there is only a single window at one end of the room facing whatever happens to exist outside - garbage dumpsters, parking lots or, if lucky, a tree or two.

The more human materials such as heavy timber columns, wood floors, clapboard siding, trim, etc. only add to the ambiance of the space. Each room includes its own exterior covered porch accessed by french doors. This allows for even more direct contact with the natural environment as well as additional options for spatial interaction, also of Japanese influence. Last, but not least, I propose that each room contain a set of modular furniture. Such things to be included are the standard bed, chairs, desk, lamp and table. The additional provision of free-standing book shelves, armoire and dresser would allow for possible further room divisions to occur. The ability to manipulate one's environment as well as a consciousness to the initial context will only help to heighten one's experiences. It will allow for greater individuality through personalization and identification thereby resulting in a sense of pride in the environment by its user.

-
1. Christopher Alexander et al., A Pattern Language (New York: Oxford University Press, 1977), pp. 668-672.

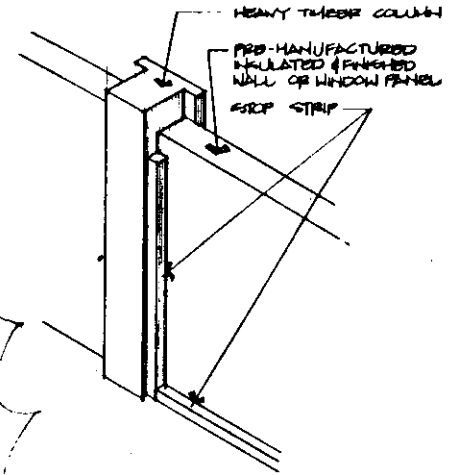
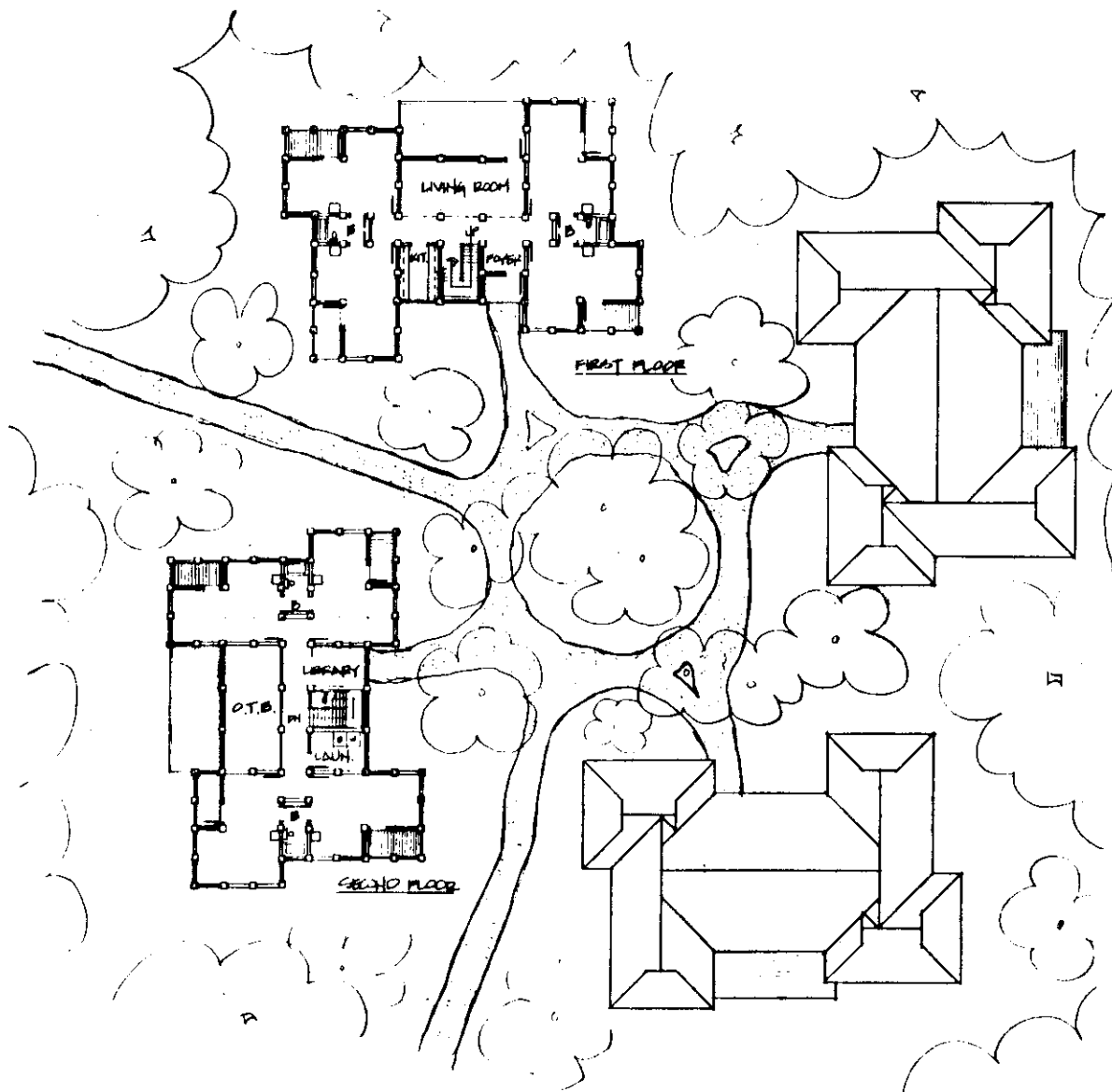

• SCHEMATIC COLUMN DETAIL (NO SCALE)

• RESIDENTIAL UNITS & CLUSTER •
 60K+ STUDENT HOUSING - 8 PER UNIT

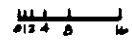

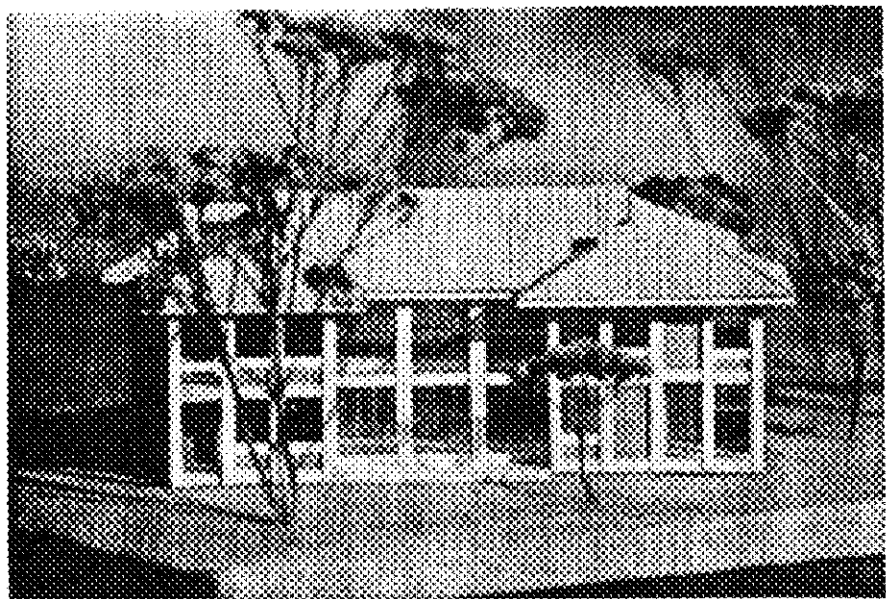
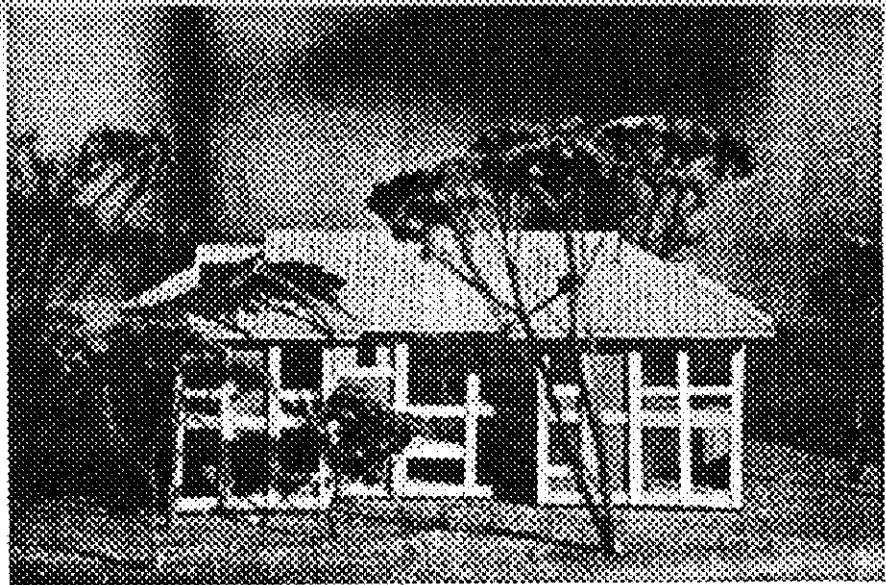

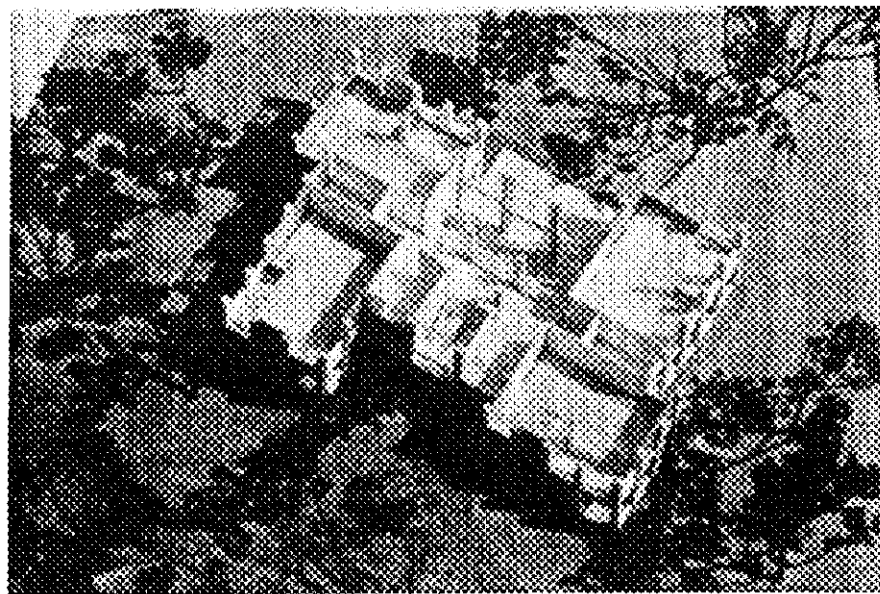

APPENDIX

