

Kenneth B. Sewell

Mashriqu'-'Adhkar

Sacred Architecture and the Baha'í Faith

May 1992

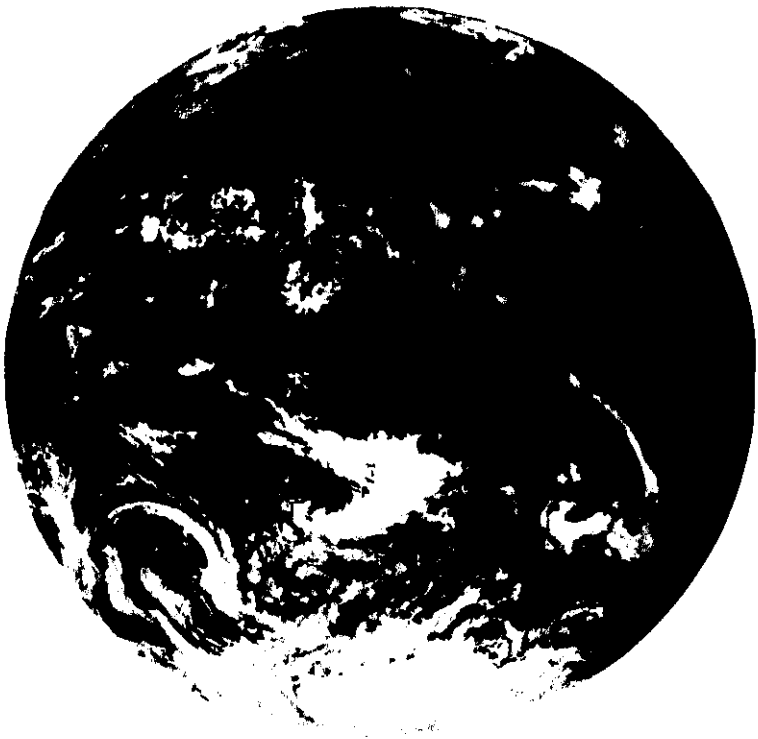

**Department of Architecture
College of Architecture and Planning
Ball State University**

Kenneth B. Sewell

Mashriq'u'l-Adhkar

Sacred Architecture and the Baha'i Faith

Bachelor of Architecture Degree Program Thesis Design

Thesis Design Committee

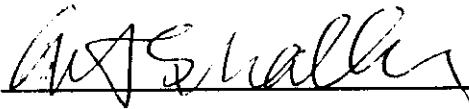

Art Schaller Professor of Architecture Studio Critic

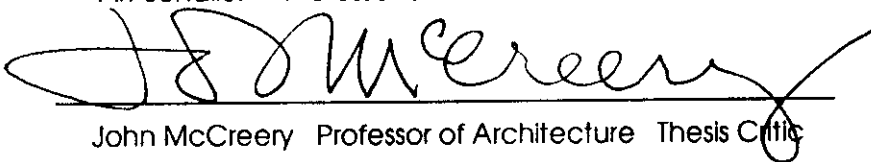

John McCreery Professor of Architecture Thesis Critic

Aeric Meredith Baha'i Thesis Critic

C o n t e n t s

I. Thesis Description	4
II. The First Process	12
III. Realzation	17
IV. The Second Process	21
A. Re - Search	
On Cosmology and the Contemporary Condition	22
The Center and the Circle	25
Mandala	28
Labyrinth	30
The Cardinal Points	31
Duality	32
The Grid	33
The Spiral	33
Water and Sky	34
The Nine Pointed Star	34
The Greatest Name	35
B. Translation	36
The Design Sequence	37
C. The Stories	43
D. The Drawings	45
V. The After-words	
A. Post-Search	53
B. Epilogue	56
VI. Bibliography	57
Appendix I: The Baha'i Faith	59
Appendix II: The Center	61
Appendix III: Sketches	88

One of the first things I did when I came to Ball State University as a Freshman was look up the Baha'i Faith in the telephone book and call them. A friend of mine in high school, Aeric Meredith, was a Baha'i and I had become intrigued about the religion. Having studied it the previous summer, I came to Ball State knowing that I had become a Baha'i. The last four and a half years have been a process of growth for me intellectually, culturally, architecturally, and spiritually. My thesis naturally became an effort to express myself on all these levels.

I have always had an interest in exploring ways of communicating with architecture. I firmly believe that architecture has the capability of communicating or embodying complex ideas, and that architecture always reveals the values, beliefs, and context of the people who commission it, design it, build it, and occupy it both intentionally and subconsciously. Architecture often communicates through symbols, metaphor, and inscriptions and statuary to create narrative spaces, elements, and sequences. Architecture also reveals values by being the physical product of decisions and positions taken on the issues of its construction (such as attitudes toward nature, people nearby, excess of wealth, etc.). I wanted to know what it was possible to say and how I could say it.

Because the Baha'i Faith is a new religion (originating in 1844), a new religious building type called a *Mashriqu'l-Adhkar*, also called a House of Worship, has been instituted. Within the House of Worship in Chicago, short services are held in which the sacred writings of the Baha'i Faith and other religions are read. At other times it is open as a place of prayer and contemplation. 'Abdul-Baha, son of the founding prophet of the Baha'i Faith, says of the House of Worship:

"Among the Institutes of the Holy Books is that of the foundation of places of worship. That is to say, an edifice or temple is to be built in order that humanity might find a place of meeting, and this is to be conducive to unity and fellowship among them. The real temple is the very Word of God; for to it all

humanity must turn, and it is the very center of unity for all mankind. It is the collective center, the cause of accord and communion of hearts, the sign of the solidarity of the human race, the source of eternal life. Temples are the symbols of the divine uniting force so that when the people gather there in the House of God they may recall the fact that the law has been revealed for them and that the law is to unite them. They will realize that just as this temple was founded for the unification of mankind, the law preceding and creating it came forth in the manifest Word. Jesus Christ, addressing Peter, said, 'Thou art Peter, and upon this rock I will build my church.' This utterance was indicative of the faith of Peter, signifying: This faith of thine, O Peter, is the very cause and message of unity to the nations. It shall be the bond of union between the hearts of men and the foundation of the oneness of the world of humanity. In brief, the original purpose of temples and houses of worship is simply that of unity - places of meeting where various peoples, different races and souls of every capacity may come together in order that love and agreement should be manifest between them. That is why Baha'u'llah has commanded that a place of worship be built for all the religionists of the world; that all religions, races, and sects may come together within its universal shelter; that the proclamation of the oneness of mankind should go forth from its open courts of holiness - the announcement that humanity is the servant of God and that all are submerged in the ocean of His mercy..." (Whitmore, pp. 59 - 60).

Of the physical form of the House of Worship and its surrounding gardens, 'Abdul-Baha stated to a baha'i in Chicago at the time of the planning stages of the House of Worship there:

"First the building, with nine sides, in the middle; then a circular court about that; leading from this circle were to be nine avenues; between each a garden, and in the middle of each garden a fountain of water." (Whitmore, p. 31).

Written on behalf of Shoghi Effendi, 'Abdul-Baha's eldest grandson and subsequent leader of the Faith after his death, a letter said of the

House of Worship's auditorium:

"As regard the whole question of the Temple and services held in it: he wishes to emphasize that he is very anxious ... that no forms, no rituals, no set customs be introduced over and above the bare minimum outlined in the teachings. The nature of the gatherings is for prayer, meditation and the reading of writings from the Sacred Scriptures of our Faith and other Faiths; there can be one or a number of readers; any Baha'i chosen, or even, non-Baha'i, may read. The gatherings should be made simple, dignified, and designed to uplift the soul and educate it through hearing the Creative Word. No speeches may be made, no extraneous matter introduced.

"The use of pulpits is forbidden by Baha'u'llah: If, in order to be more clearly heard, the person stands on a low platform, there is no objection, but this should not be incorporated as an architectural feature of the building ...

"Vocal music alone may be used and the position of the singers or singer is also a matter for your Assembly to decide; but again, there should be no fixed point, no architectural details marking a special spot. Acoustics should certainly be the main consideration in placing the singers." (Hornby, pp. 488 - 489).

Around the House of Worship are to be humanitarian, charitable, and educational facilities to aid the poor, sick, physically and mentally handicapped, aged, orphans, and ignorant of the community. (Whitmore, p. 240).

Eight Mashriqu'l-Adhkar have been built, but only seven remain standing today. The first was built in Ashkhabad, Turkistan which is in the former Soviet Union. The Baha'is were eventually expelled by the communists and the Baha'is, like all religions in the Soviet Union, were heavily persecuted. After falling into disrepair and suffering severe structural damage in an earthquake, the House of Worship was demolished in the 1960's. The others, which were built with the guidelines established above (the House of Worship in Ashkhabad

was designed in an Islamic style much like a mosque, and even had minarets) are located in the United States, Germany, Panama, Australia, Western Samoa, India, and Uganda. Though all of them are radially symmetrical, a wide variety of expression already exists. I will explore the idea of a radially ordered structure to alter the idea of a strict symmetry.

Kampala, Uganda



New South Wales, Australia

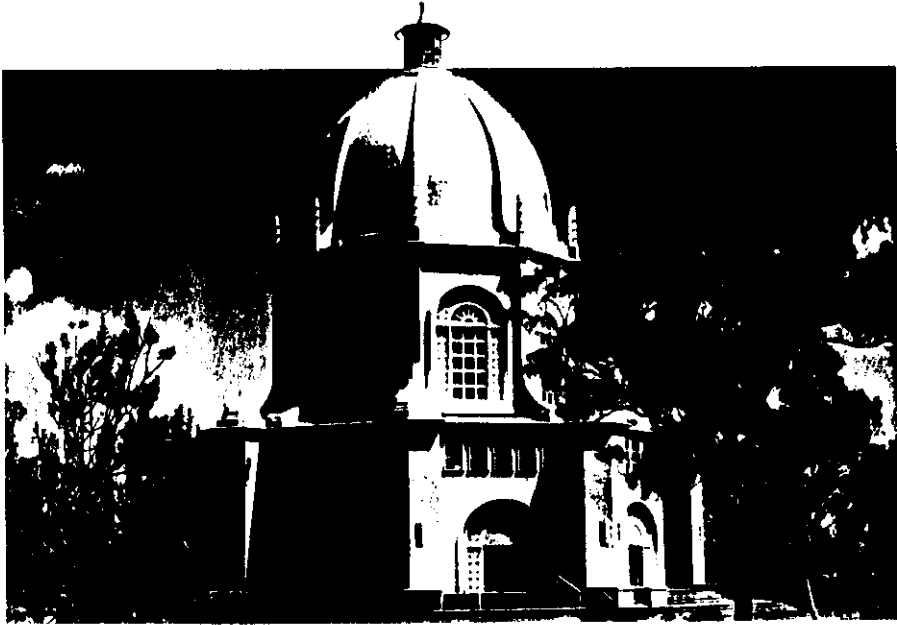

New Delhi, India



Near Panama City, Panama

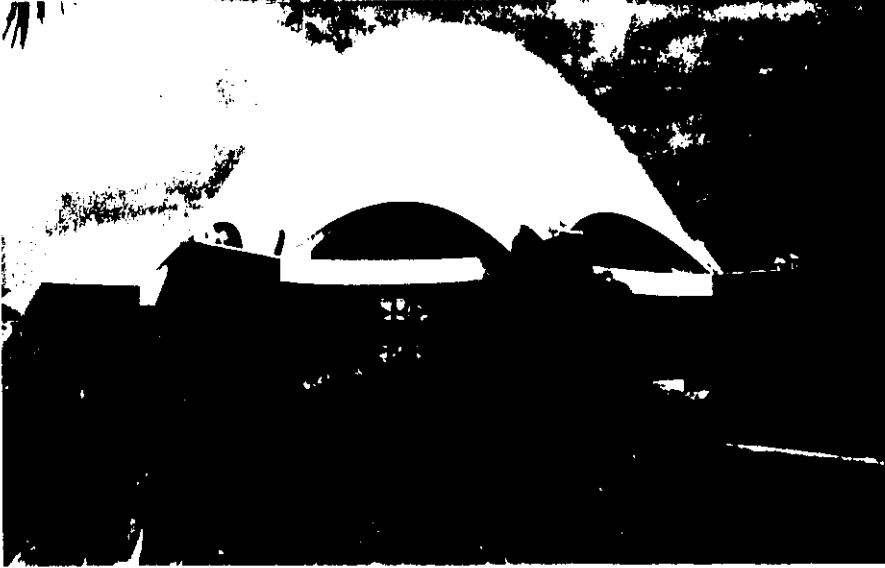

Langenhain / Hofheim, west of Frankfurt, Germany

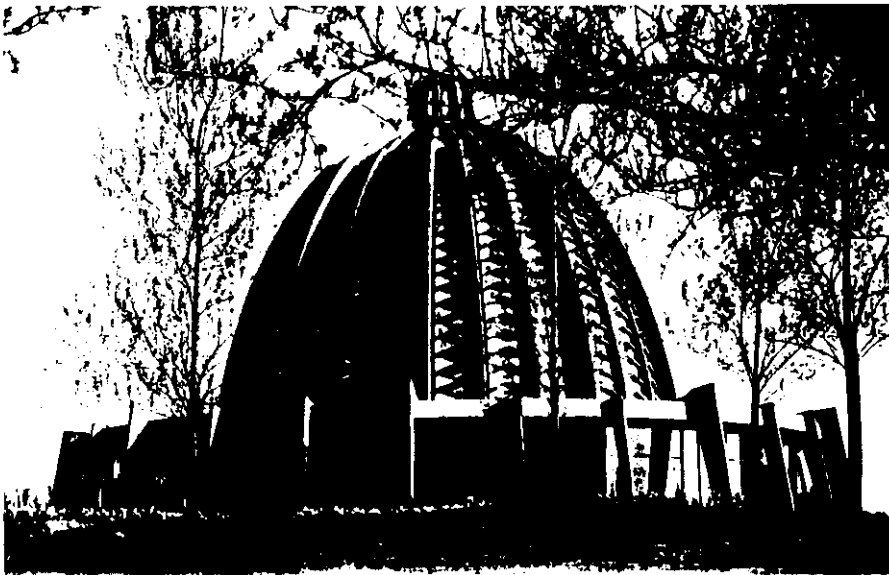

Near Apla, Western Samoa

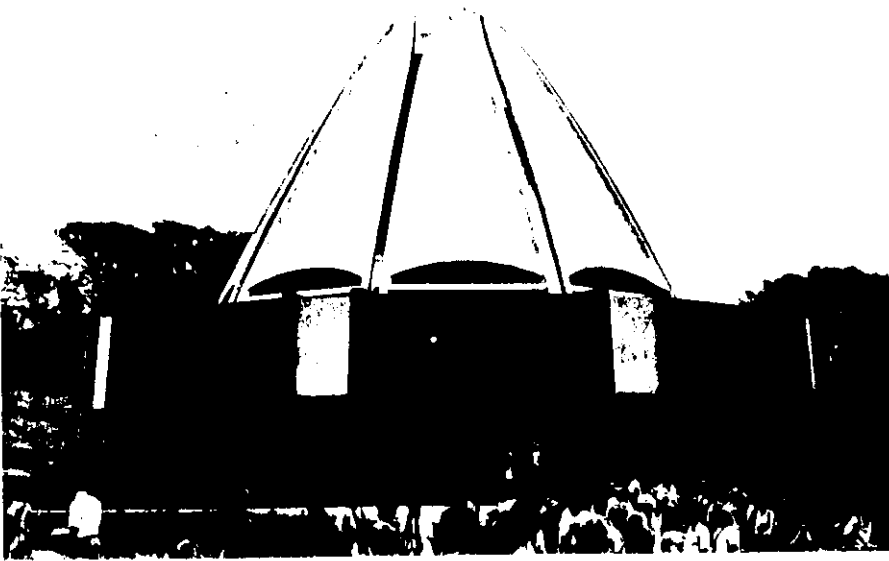

Wilmette, IL, U.S.A.

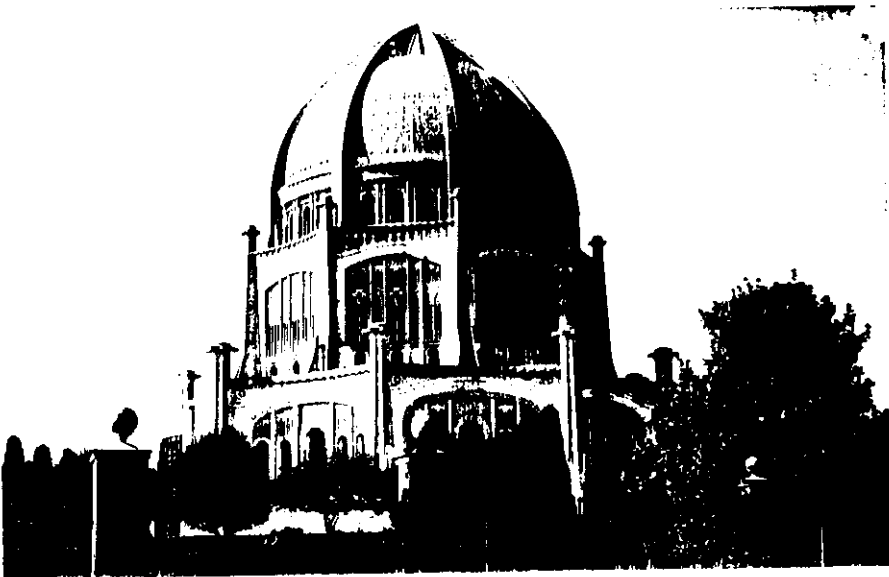

"But however inspiring the conception of the House of Worship, as witnessed in the central Edifice of this exalted Temple, it cannot be regarded as the sole, nor even the essential, factor in the part which the Mashriqu'l-Adhkar, as designed by Baha'u'llah, is destined to play in the organic life of the Baha'i Community. Divorced from the social, humanitarian, educational and scientific pursuits centering around the Dependencies of the Mashriqu'l-Adhkar, Baha'i worship, however exalted in its conception, however passionate in fervor, can never hope to achieve beyond meager and often transitory results produced by the contemplation of the ascetic or the communion of the passive worshiper. It cannot afford lasting satisfaction and benefit to the worshiper himself, much less to humanity in general, unless and until translated and transfused into that dynamic and disinterested service to the cause of humanity which it is the supreme privilege of the Dependencies of the Mashriqu'l-Adhkar to facilitate and promote. Nor will the exertions, no matter how disinterested and strenuous, of those who within the precincts of the Mashriqu'l-Adhkar will be engaged in administering the affairs of the future Baha'i Commonwealth, fructify and prosper unless they are brought into close and daily communion with those spiritual agencies centering in and radiating from the central Shrine of the Mashriqu'l-Adhkar. Nothing short of direct and constant interaction between the spiritual forces emanating from this House of Worship centering in the heart of the Mashriqu'l-Adhkar, and the energies consciously displayed by those who administer its affairs in their service to humanity can possibly provide the necessary agency capable of removing the ills that have so long and so grievously afflicted humanity. For it is assuredly upon the consciousness of the efficacy of the Revelation of Baha'u'llah, reinforced on one hand by the intelligent application and the faithful execution of the principles and the laws He revealed, that the salvation of a world in travail must ultimately depend. And of all the institutions that stand associated with His Holy Name, surely none save the institution of the Mashriqu'l-Adhkar can most adequately provide the essentials of Baha'i worship and service, both so vital to the regeneration of the world. Therein lies the secret of the loftiness, of the potency, of the unique position of the Mashriqu'l-Adhkar as one of the outstanding institutions conceived by Baha'u'llah." (Hornby, pp. 487 - 488).

II. The First Process

My initial concept was to have a large circular wall with nine entrances that lead to nine gardens. Each was to incorporate a didactic narrative about a particular aspect or teaching of the Baha'i Faith. As people moved through this garden, they would experience various open architectural spaces, objects, and landscape features that would be used to create a statement with the formal environment. The center would be occupied by the House of Worship. What follows are edited excerpts from my sketchbook that explain the beginning of my process which begins with site selection:

I desired a site with a coastal view. The image of the ocean has tremendous poetic depth. It is found throughout the Writings, and also there is the healing power it offers the mind and soul. The meditative states it induces are appropriate and desirable for the project. I also desired mountainous, hilly, or rough terrain. Some intense natural environment that would force the land and architecture to confront each other.

I wanted the country I chose to be a country full of turmoil. The Writings focus on peace and unity, therefore a country torn apart would benefit the most from the existence of a House of Worship. The very presence of a House of worship evokes much energy for peace, cooperation, and unity. Some countries I considered were Egypt, Yugoslavia, South Africa, Indonesia, Iran, Ireland, and several others.

(I eventually chose a site in the Philippines because it fulfilled all this criteria, and also because I know I will visit this country in the near future.)

The exact site is about forty miles from Manila, across Manila bay. It is between two dormant volcanoes at the end of a valley. It sits on a promontory about 400 meters above the South China Sea. It is

called Mapalan Point and is near Malawin and Kabayo. The valley is a rice paddy and is probably a very economically depressed area. The South China Sea is to the west and south, Subic Bay is to the northwest, Manila is east. The road to this place is probably eighty miles long. More likely there could be a ferry across the bay which would be more direct.

Haifa, Israel, the location of the Baha'i World Centre where the shrines of the Founders of the religion the Bab and Baha'u'llah are, is ten degrees north of due west. Baha'is turn toward this place at least once a day to pray.

(As to the initial siting and proportioning of the outer circular wall, and ideas for the narrative gardens:)

Art Schaller and I were discussing the issue about how the sizes and proportions would be determined. He thought that it was incredibly important that the choices be intentionally and tightly bound to the number nine. ... One idea is to take nine and multiply it by other common numbers in the Baha'i Faith which are five, nineteen, and ninety-five. Applied to the diameter of the circular wall and avenue, I found two numbers: $9 \times 9 \times 9 = 729'$ and $9 \times 95 = 855'$. These feel like workable diameters for the circular walk. However, they are rather arbitrary, unperceived numbers. An idea I had was to work with the circumference of the circle instead. If a person has a stride of roughly three feet, possibly this could be a more perceptual unit of measure than an abstract foot. So I tried this. $95 \text{ steps} \times 3 \text{ ft./step} \times 9 \text{ entrances} = \text{a circumference of } 891 \text{ steps or } 2565 \text{ ft.}$ The diameter of this circle is roughly 817 ft. However, by using a two and a half foot step, a diameter of 681 ft. results.

I have discovered that there is a 300 ft. cross on top of Mount Samat, which is five miles from my site.

I am trying to name or find the themes of the nine gardens that lead to the House of Worship. So far I have:

Consultation

The idea is that two people with conflicting views on a matter stand on either side of a wall. The wall becomes a wedge shape. There are windows for each person to talk to the other person through. As the 'V' gets wider, the people must yell in order to hear one another, disturbing others who have entered the 'V'. The people in opposition must agree to enter the 'V' and talk - or consult - with each other and others there and solve their dispute. The point of the 'V' will most likely point to Halfa. The walk outside the 'V' will rise and it will be impossible to enter the House of Worship from there. Entering the gardens of consultation is vital, and the only way to the House of God. The interior of the 'V' is devoted to consultation and must be conducive to it - yet also represent the processes of spiritual discussion.

(The garden was intended as a metaphor and not as an actual setting for this to take place.)

The Straight Path

This would be symbolic of the idea that to follow a religious teaching is to not stray from a straight and clear path. To wander off this path is to deviate from your growth spiritually and to become decentered and lost. This would also serve as the main entrance avenue to the House of Worship.

The Garden of Humility

A large open plaza with an immense and probably featureless wall at the end. There would be an opening near the top showing the House of Worship beyond. A large stair rises up to the opening appearing to lift people up above the people on the plaza through the wall to the House of Worship. At the top of the stairs is the platform of the proud man, and it does not go through the opening to the

House of Worship. The platform stops far short of having access to the sacred structure, and the people at the top must return to the bottom and search with the others on the plaza for a way to gain access to the House of Worship. As approached from below, a small opening is found that only allows you to bend down and pass through. The large wall is curved slightly to focus attention back toward the center. Pushing out those who will not seek, and embracing those who do.

The Garden of Race Unity

Multi-colored paths and walls represent different races. The choreography of the paths will narrate, like a dance, a story about the interaction of races. They will begin to converge and mix and eventually all rise equally to the House of Worship.

Science and Religion

The image of a narrow grid path over a large area of water is a strong image in my mind. I am reminded of rice paddys. One way I could work with this image is to have the water flow from one square to another that would lead to the center. Baha'is believe in the idea that science and religion are two sources of knowledge that coexist and enhance, not contradict one another. Science without religion becomes empty and vulnerable to destructive intentions, and that religion without science becomes superstitious and fanatical, as well as contradictory.

Water is often used in the Writings as a symbol of Divine knowledge, spiritual purification. Using water as a symbol may be enough to compete with the dominance of the grid. I think that passing below a large waterfall and finding behind it the stairs to the House of Worship would be a very spiritual statement. The sound and experience of it would also be intense.

Other ideas: some paths about nature, environmental issues; tradition; government; ending extremes of poverty and wealth; ending

prejudice and racism; progressive revelation of religion; balance and moderation; persecutions; the need for divine guidance.

(I began to look at my design process)

Something that has occurred to me - my process is a journey, and this metaphor is appropriate on a few different levels. Much like zooming in with a camera, the scale that I look at has been decreasing as I get closer and closer. I started with the globe, found a country, found a region, found a physical site, then it's as if I am still physically approaching it. Arrival point, the circle, then the gardens. As I get closer, more is revealed. At the center is my goal, the House of Worship. I can't see it yet. The project is revealing itself the way I want it to others. It is becoming a model - a real living model - of spiritual progress. The symbols are happening. This design is - as it should - symbolizing my own search for spiritual growth. I try to get closer and closer to the center of my faith. I am finding it fascinating and difficult. I'm worried I may not get there - and not in time. I must concentrate and be strong spiritually.

After reading some of the Writings in an effort to translate them to architecture, I ran into the difficulty that they are usually commands to turn away from the physical and to the spiritual. Yet I'm using the material to convey this. How? I'm running into contradictions. In one instance I could use the maze-like, fearful quality of the rain forest as a symbol for the lost, the earthly, non-spiritual. However, it could also be used the beautiful Eden from which many metaphors and ornaments are drawn in the Writings. Is it on the path to the center or off? I am having trouble with ambiguous readings that could contradict each other. Say a person goes off the path to the House of Worship, and I want this to represent the straying from the Divine Path, what do they enter when they leave this path? A rainforest? A maze? A cell? How can I use these elements to communicate only one message?

III. Realization

(With nearly a third of the semester gone, I had an evening that caused me to realize. I wrote one evening:)

I've been carrying this sketchbook around for weeks now - writing less and less. Feeling more and more intimidated. I've been scaling back the project more and more - a humbling process. I began this thesis with the thought that it would be a grand project, and obliged myself into doing it without considering my readiness. As I have gotten into it, it has become larger and larger - there is *so much* to do. My feeling of confidence has diminished as I felt the project expanding into much more work than I could handle. As the deadline becomes impossibly close, and as I have discovered that to undertake such a project, I really must be completely spiritually centered and healthy. I have not felt this way lately. I have become distracted, uncentered, and slacking. I haven't been around Baha'is nearly enough. With them I feel my energy and focus return. I struggle to maintain it when I am away.

All in all, I've been becoming depressed at the prospect - and likelihood - that my expectations for this project will not be met - not even the scaled down version which has been disturbing me as shallow and not enough. Recent critiques have left me with even more that I know will take me even longer to answer properly. Questions I *want* to answer.

I have also been having problems drawing and writing in this sketchbook and elsewhere. I'm afraid that the drawings will be ugly (I don't think my sketches are graphically attractive, though they effectively communicate to me), or that the writing will be too sloppy or not well written or thought out. I am uptight that this might not be a beautiful, concise, complete document of my design process. I have become vain in my own sketchbook and it has stopped talking to me.

As this realization and frustration and confusion has been building within me, I have tried to work it out by scaling down the project, refocus it. And also by praying more, deepening, recentering myself, and working harder to be strong. Contact with Baha'is also helps me remember who I am.

All of this brings me to tonight. Theory / Method class was tonight and we discussed, as a class, topics we've each chosen for a paper we have to write for the class (see Appendix II). Hoping to push more of my attention toward the faith and my thesis, I was going to write mine about the Baha'i perspective on history and how it relates to architecture. I was going to do this in four steps or so:

A. I would start by presenting the idea that architecture - as well as other creative processes - reveals the values, beliefs, and context of those who make it. Architecture always speaks of this - intentionally or otherwise. In the most dense expressions, architecture reveals a cosmology.

B. Then I would talk about current images and ideas in architecture that seem - to me - to represent 'life out of balance,' nihilism, atheism, disillusionment, fragmentation. Deconstruction.

C. I was then going to introduce the faith. Explain what it is briefly, establish it as a new world religion.

D. Then I was going to talk about various ways that the ideas and teachings change the current philosophical cosmology that contemporary architecture is responding to.

However, presenting this in class, I was unable to clarify point D very well and no one understood, particularly Sonny Palmer. He asked me at one point: Are you writing this to toot the horn of this religion of yours? He had been probing me to try to understand, and yet unintentionally intimidated me to the point where I was unable to make clear what I was thinking. So when he asked me this, I said immediately - no. I do not want to nor believe I could proselytize. My intention was to present new, optimistic ideas and spark interest in the

subject. But on closer thought after the conversation, I realized that it may seem in this audience that my intention would be misconstrued. I thought that my paper would excite the people to the Faith, which is a bit heavy handed and a bit presumptuous in this situation. I was only going to make an attempt at this paper; I am far from qualified as a historian. So - yes, maybe I was trying to toot the horn of the Baha'i Faith. For this paper, this was not my intention, so I had another idea.

My paper was going to discuss parts A. and B. of my first idea. I want to present how societies, particularly religious cultures create cosmologies with architecture. For example I might survey several building types that have achieved a degree of refinement and density as a culture's image of itself, such as cathedrals, mosques, temples, skyscrapers, commercial architecture, native American structures, and then move on to Deconstruction. I want to discuss each schematically to show how each major feature of the building contributes to a larger narrative about the people who built it.

So after finding this idea for the paper, I decided that my thesis should do the same. After my introspection I was ready to throw out my previous work - or at least put it in limbo - and find a new approach, which came the kind of rigorous questioning I had been previously avoiding. I decided that my thesis should be to create this architectural image of the Baha'i Faith and baha'is, and if possible connect it to the people of the Philippines. However I am so bogged down with the site, that I may focus my energy into more universal ideas.

At this point I started over. The research I began at this point continued to even past my final thesis presentation; I found so much. Out of the frustration came the desire to recenter, which allowed me to see clearly that a new beginning was necessary. Had I pushed on

I would have only continued to rationalize and compromise. What follows is my new beginning or The Second Process.

A look at words:

Thesis: A hypothetical proposition put forth as a question, problem, or theory to be tested and researched.

Hypothetical: Of or pertaining to a statement that can be tested by further investigation.

Proposition: A plan or scheme suggested for acceptance.

Question: An expression of inquiry that invites a response.

Problem: A question or situation that presents an uncertainty or unknown.

Test: A series of questions or problems designed to determine validity or truth.

Research: An investigation of recorded knowledge or **look again**.

IV. The Second P r o c e s s

The second process began with research. I wanted to access the intimate forms and symbols of the sacred. To find archetypal forms and symbols and study their phenomenological narratives, guided my search. The cosmological myths and theology of places of worship and their existential purpose to the believers' lives was also important to me. One valuable source of information came into my hands after my presentation was finished, but I will include that research as well. Though it may have not directly influenced the design, it reinforces the design and helps me understand where I stand now and where to explore next.

For me a House of Worship's primary sources for meaning can be talked about on two levels: the universal spiritual concepts, and local contextual forces. The universal concepts constitute a set of beliefs and ideals that are true to all sacred space. They are what define the basic ideas of religion and spiritual interaction on the broadest terms. The contextual forces are the actual people of a particular place that adopt this spiritual framework, yet understand and use it within their own culture. This is much like the writings of the various religions. All religions proclaim the same set of basic truths about the nature of God and spiritual living. However, the teachings about social and cultural laws are often different, because they are shaped by the historical context within which it comes to being and differ from religion to religion. An analogy often used for this idea is that of a Divine Physician. Each civilization of each religion represents the patient. The patients have different ailments and thus require different treatments and methods for healing, but the patient Doctor relationship and goal to be healthy is always the same. Therefore the thesis project can be divided into these two types of concerns, the spiritual truths and the context. I focused on understanding better the former before attempting to effectively address the latter.

Because spiritual concepts and experiences are difficult to talk about, symbols are used to bypass the inadequacies of written and spoken language. The recurrence of similar symbols and their meanings indicates to me a similarity in spiritual experience; which corresponds to the baha'i idea that there is one God, that all religions come from this same God, and that mankind is one. I began to research these symbols as a possible access to the spiritual experi-

"Are there symbols which may be called constant; proper to all races, all societies, and all countries?"

-Cesar Daly

"The Tao that can be told is not the permanent Tao; The names that can be given are not the permanent names."

-Lao - Tsu

ences and truths we all share regardless of our religious creed, and hoped that from this common unified source, a language could be found to speak about the spirit to everyone.

What follows are some of the symbols and archetypes I found and seemed relevant. Many more exist and many overlap. Underneath many are some essential and vital truths that begin to reveal the nature of our physical and spiritual existence. The symbols selected and the research assembled are the faintest scratch on a seemingly infinite surface. I present much of the research as directly quoted text in an effort to preserve the eloquent state I found it in and not water down already elusive concepts. Hopefully the paraphrasing exists in the architecture.

On Cosmology and the Contemporary Condition

"The Norseman on the image of his house fashioned his picture of the entire world. The earth with the heaven for a roof, was to him but a mighty chamber, and likewise had its great supporting tree, passing through the midst and branching far upwards among the clouds." (Lethaby, p. 36).

"Above the ground was 'the over-sea' which was perforated for the rain or it ran down the mountains." (Lethaby, p. 15).

"When the world was (mythologized to be) a tree, every tree was in some sort its representation; when a tent or a building, every tent or building: but when the relation was firmly established, there was action and reaction between the symbol and reality, and ideas taken from one were transferred to the other, until the symbolism became complicated, and only particular buildings would be selected for the symbolic purpose. Certain forms were reasoned from the building to the world, and conversely certain thoughts were of the universe were expressed in the structure and thus set apart as a little world for the House of God - a Temple." (Lethaby, p. 35).

"The human psyche is essentially the same all over the world. The psyche is the inward experience of the human body, which is essentially the same in all human beings. With the same organs, the same instincts, the same impulses, the same conflicts, the same fears. Out of this common ground is what Carl Jung called archetypes." (Campbell, p. 51).

A. Re-Search

"(Archetypes) are elementary ideas, what could be called 'ground' ideas. ... All over the world and at different times of human history, these archetypes, or elementary ideas, have appeared in different costumes. The different costumes are the results of the environment and historical conditions." (Campbell, pp. 51 - 52).

"The Gothic cathedrals of the Thirteenth Century mark the last phase of an attempt at creating an integrated, highly centered, cultural complex in the European west. These temple complexes are part of a highpoint of a planetary wave of human culture. Despite geographical isolation, a unitary human purpose, design, and meaning becomes apparent in the erection of cathedrals, mosques, and temples in the general period of the Tenth through Fifteenth centuries: Kajuraho in India, Borobudur in Java, Angkorwat in Indochina, Chartres in France, Cordoba in Islamic Spain, and Chichen Itza in Yucatan. The world view which these edifices have in common is that the society in which he lives is a map of the cosmos." (Arguelles, p. 44).

"The four elements - air, fire, water, and earth - which are the most elementary modes of manifestation of all matter to offer themselves to our senses, are almost everywhere - with exception of the modern, rationalistic world - endowed with the quality of sacredness; from this point of view, earth is illimitable, air is ungraspable, fire is in its very nature undefilable; only water is open to violation and is therefore commended to special protection. ... From an inward point of view, on the other hand, they are also the simplest images of our soul, which as such is ungraspable, but whose fundamental characteristics can be likened to the four elements." (Burckhardt, pp. 126 - 127).

"(Modern man) sees the sky above him like any child sees it, with its sun and its stars, but the remembrance of the astronomical theories prevents him from recognizing the divine signs in them." (Burckhardt, p. 32).

"The contemporary condition of an absence of symbols is due to the demystification of religion by science and the change from an agrarian culture to an urban society." (Davies, p. 3).

"One of our problems today is that we are not well acquainted with the spirit. We're interested in the news of the day and problems of the hour." (Campbell, p. 3).

"Modern man knows that the earth is only a ball suspended in a bottomless abyss and carried along in a dizzy and complex movement, and that this movement is governed by other celestial bodies incomparably larger than this earth and situated at immense dis-

stances from it. He knows that the earth on which he lives is but a grain in comparison with the sun, which itself is but a grain amidst other incandescent stars, and that all is in motion. An irregularity in this assemblage of sidereal movements; an interference from a star foreign to our planetary system; a deviation of the sun's trajectory, or any other cosmic accident, would suffice to make the earth unsteady in its rotation, to trouble the course of the seasons, to change the atmosphere, and to destroy mankind. Modern man knows that the smallest atom contains forces which, if unleashed, could involve the earth in an almost instantaneous conflagration. All of this, from the 'infinitely small' to the 'infinitely great,' presents itself, from the point of view of modern science, as a mechanism of unimaginable complexity, the functioning of which is only due to blind forces." (Burckhardt, pp. 31 - 33).

"...the system of naturalism was complete. Man could explain anything from the smallest atom to the farthest star; he could even explain himself in purely physical terms, with no need to consider how a world of the spirit might influence the physical one." (Kelsey, p. 8).

"...men have lost any sure conviction that their lives have meaning. They doubt that there is anything but the physical world. That this very time when men most need meaning and direction to turn to, they find in most places the attitude that only skill and science and reason count. If there is any meaning to be found they must go back to the turmoil and look for it." (Kelsey, p. 7).

"...men are forced to search for meaning on their own. They face fear and anxiety; they have to deal with aggression and hostility which cause misery within and between men. They suffer an almost indefinable heaviness, and often live with depression day in and day out which most psychiatry seems powerless to heal. Or again, they express the lostness outwardly in alcoholism and drug addiction. It appears that none of these disturbances can be healed except by a sense of meaning, given by a contact with that reality from which meaning originates." (Kelsey, p. 10).

"...today there are no boundaries. The only mythology that is valid today is a planetary mythology - and we don't have such a mythology." (Campbell, p. 22).

"It is as if the mirror of unity which the cathedral builders had shown to European man had been broken and dissolved. But what European man had done in the breaking of this mirror had inevitable planetary consequences, for in the destruction of the mirror of unitive vision, demonic energies were unleashed, energies that would not be satisfied until every last unitive mirror in the world had been broken, or at least concealed by the smoke of wrathful acquisitive powers." (Arguelles, p. 44).

The Center and the Circle

"In the beginning was the Center: the center of the Mind of God, the eternal Creator,...the center is symbolic of the eternal potential. From the same inexhaustible source all seeds grow and develop, all cells realize their function; even down to the atom there is none without its nucleus, its sun-seed about which revolve its component parts." (Arguelles, p. 12).

"Centered space is vital and insists upon intruding itself. Centered space propels us out of the modes of experience in which space is used as a means. ... We see and feel space not as a receptacle containing things, but rather as a context empowered by the positioned interrelationship of things. Centered space intrudes as a force that is both 'other' and imposing, as, even in our most harassed moments, we can hardly help feeling..." (Martin, p. 229).

"Feeling the impulse towards wholeness, man applies it to all that he does. It motivates his thoughts, permeates his activities, and resides in all that he constructs. In his dwellings, as in those of most of the 'primitive,' pre-industrial world, there is a place, an altar, a fire, a stone

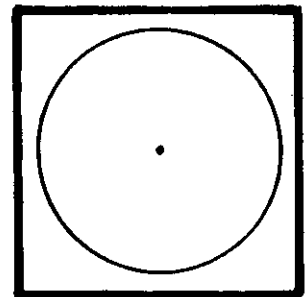

that is the center, not only of the house or dwelling, but also of the entire cosmos. This is no inherent contradiction, for we are talking about what is primarily a *sacred* principle, or a sacred state of consciousness in which all beings and all things are realized equally as emanations of One Divine Whole." (Arguelles, p. 16).

Speaking of Laurette Sejourne:

"Understanding the Law of the Center as a basic principle of nature, men have been able to construct vast systems, and perceive various levels of order throughout the universe. From the Law of the Center, men have also derived a developmental or even hierarchical ordering principle. Since the center itself is identified with a source of power, wisdom, and life, it occupies the 'highest' or innermost place within the entire concentric arrangement. The center is the 'nameless,' the most supreme, the oldest, yet is ever-present and continually pours forth its energy - It is self-renewing." (Arguelles, p 60).

"The circle is the original sign, the prime symbol of the nothing and the all; the symbol of heaven and the solar eye, the all encompassing form beyond and through which man finds and loses himself. This is the originless Mandala. No race is without it, for it comprises All, its source and its ending." (Arguelles, p. 33).

"The whole world is a circle. All of these circular images reflect the psyche, so there may be some relationship between these architectural designs and the actual structuring of our spiritual functions... The circle ... represents totality. Everything within the circle is one thing, which is encircled, enframed. That would be the spatial aspect. But the temporal aspect of the circle is that you leave, go somewhere, and always come back. God is the Alpha and the Omega, the source and the End. The circle suggests immediately a completed totality, whether in time or in space." (Campbell, pp. 214 - 215).

"The circle is a symbol of the psyche. The square (and often the rectangle) is a symbol of earthbound matter, of the body, and of reality. In most modern art, the connection between these two primary forms is either nonexistent, or loose and casual. Their separation is another symbolic expression of the psychic state of the Twentieth Century man. His soul has lost its roots and he is threatened by dissociation." (Jaffe, p. 284).

"While the square is closely connected with man and his constructions, with architecture and building forms, lettering, etc., the circle is related to the Divine. Since ancient times a simple circle has represented eternity, for it has neither beginning nor end. An old text says that God is a circle whose center is everywhere, but whose circumference is nowhere." (Munar, p. 5).

"But the frequency with which the square and the circle appear must not be overlooked. There seems to be an uninterrupted urge to bring into consciousness the basic factors of life that they symbolize." (Jaffe, p. 284).

"According to Jung, the circle symbolizes essentially the processes of nature or the cosmos as a whole, while the square refers to the universe as conceived by man. The circle represents both the subconscious and the superconscious aspects of nature, where as the square is related to conscious rational aspects. In their integration these two represent a holistic view." (Arguelles, p. 38).

Everything the Power of
the World does is done in a circle. The
sky is round, and I have heard that the earth
is round like a ball, and so are all the stars. The wind,
in its greatest power, whirls. Birds make their nests in
circles, for theirs is the same religion as ours. The sun comes
forth and goes down again in a circle. The moon does the same,
and both are round. Even the seasons form a great circle in their
changing, and always come back again to where they were. The life
of a man is a circle from childhood to childhood, and so it is in every-
thing where power moves. Our tepees were round like the nests of birds,
and these were always set in a circle, the nation's hoop, a nest of many
nests, where the Great Spirit meant for us to hatch our children.

Black Elk,
Black Elk Speaks
(Arguelles, p. 60)

Mandala

"The mandala is fundamentally a visual construct which is easily grasped by the eye, for it corresponds to the primary visual experience as well as to the structure of the organ of sight. The pupil of the eye itself is a simple mandala form. The eye receives light and projects images outward through the form of the pupil, that is, through the center of an elementary circle." (Arguelles, p. 23).

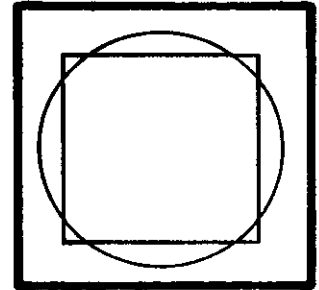

"The Sanskrit word *mandala* means 'circle' in the ordinary sense of the word. In the sphere of religious practices and in psychology it denotes circular images, which are drawn, painted, modelled, or danced." (Jung, p. 235).

"The contemplation of the mandala is meant to bring an inner peace, a feeling that life has again found meaning and order." (Franz, p. 230).

"The mandala has appeared throughout man's history as a universal and essential symbol of integration, harmony, and transformation. It gives form to the most primordial intuition of the nature of reality, an intuition that inheres in each of us, giving us life." (Arguelles, p. 33).

"The mandala serves a conservative purpose - namely to restore a previously existing order. But it also serves the creative purpose of giving expression and form to something that does not yet exist, something new and unique. The second aspect is perhaps even more important than the first, but does not contradict it. For in most cases, what restores the old order simultaneously involves some element of new creation. The process is that of the ascending spiral which grows upward while simultaneously returning again and again to the same point." (Franz, pp. 247 - 248).

"Mandala is a *centering* technique, a process of consciously following a path to one's center. A fully individuated being, no matter what may occur to him outwardly, is able to maintain contact with this center, to assimilate and recreate all experience without losing touch with the vital source of his being." (Arguelles, p. 20.)

"... the mandala is essentially a vehicle for concentrating the mind so that it may pass beyond its usual fetters. ... It symbolizes various levels of awareness within the individual well as the energy that unifies and heals. Making a mandala is a universal activity, a self-integrating ritual." (Arguelles, p. 15).

The 'squaring of the circle' is one of the many archetypal motifs which form the basic patterns of our dreams and fantasies. But it is distinguished by the fact that it is one of the most important of them from the functional point of view. Indeed, it could be even called the *archetype of wholeness*." (Jung, p. 236).

"One of (the alchemists) central symbols was the *quadratura circuli* (the squaring of the circle), which is no more than the true mandala." (Jaffe, p. 278).

"When I began drawing the mandalas, however, I saw that everything, all the paths I had been following, all the steps I had taken, were leading back to a single point - namely, to the mid-point. It became increasingly plain to me that the mandala is the center. It is the exponent of all paths. It is the path to the center, to individuation." (Jung, p. 234).

"The mandala is a metaphysical structuring principle. Symbolic systems are valid for human development to the degree that they point to a way of creative living - the conscious attunement of man to the cosmic rhythms so that his daily life manifests in every way a sense of harmony." (Arguelles, p. 72).

"Beyond its inherent and captivating beauty, sacred art is the formal aspect of a system of symbols. Symbols are containers of various levels of knowledge, and relate to far more than what they superficially embody. They are created through condensation and focalization of energies, and by a reciprocal process, can release those

stored energies. A coherent set of symbols constitutes a symbolic system. These systems are often constituted in the form of a mandala, for they attempt to define the processes of nature as a set of interrelationships unified into a formulable whole." (Arguelles, p. 53).

"...Jung concluded that there was a built-in tendency to think in certain geometrical categories. He took as one of these archetypes, the Mandala. In Buddhist thought the mandala represents both a kind of Ideological map of the universe, and a map of human personality. Jung suggested, for example, that architects build cities of concentric squares and circles because they have mandala archetypes stored in their unconscious minds, and not because of the physical properties of building materials or social needs." Mackay, p. 69.

The Labyrinth

"It has been suggested that the maze was a symbol of life and the coil of sin. The whole device was deemed to be indicative of the complicated folds of sin by which man is surrounded, and how impossible it would be to extricate himself from them except through the assisting hand of Providence.'" (Lethaby, p. 150).

"A labyrinth is a defense, sometimes a magical defense, built to guard a center, a treasure, a meaning. Entering it can be a rite of initiation, as we see in the Theseus myth. That symbol is the model of all existence, which passes through many ordeals in order to journey towards its own center, toward itself, toward atman, as the Hindus call it. There have been occasions when I have been aware of emerging from a labyrinth, or of coming across the thread. I was feeling hopeless, oppressed, lost. Of course I didn't actually say to myself: 'I am lost in the labyrinth.' And yet, in the end, I did very much have the

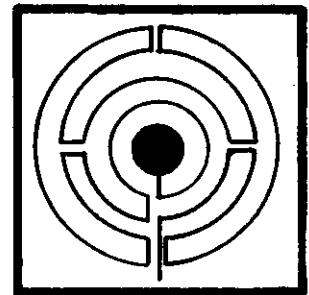

feeling of having emerged from the labyrinth as victor. Everyone has that experience. But one must also add that life is not just one labyrinth. The ordeal reoccurs." (Eliade, p. 185).

"Once the center has been reached, we are enriched, our consciousness is broadened and deepened, so that everything becomes clear, meaningful; but life goes on. Another labyrinth, other encounters, other kinds of trials, on another level." (Eliade, pp. 185-186).

The Cardinal Points

"(Having a building squared to the cardinal points) was talismanic assurance of permanence and stability." (Lethaby, p. 64).

"A pyramid has four sides. These are the four points of the compass. ... When you're down on the lower levels of this pyramid, you will be either on one side or the other. But when you get to the top, the points all come together, and the eye of God opens up." (Campbell, p. 25).

The astronomical symbol for the earth is:

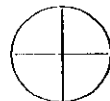

"No matter how civilized we become, we must still answer for ourselves the basic question of self-orientation, and in this respect our condition is no different than that of our first ancestors stepping out of the forest into the light." (Arguelles, p. 16).

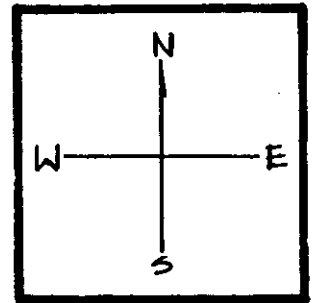

Duality

"The Yin / Yang principle represents the constant change and motion of the universe and thus of human experience." (Reifler, p. 5).

"The way to be is not to be."

-Lao - Tzu

The Yin / Yang symbolizes duality.

East

<u>Yin</u>	<u>Yang</u>
feminine	masculine
negative	positive
yielding	strong
follower	leader
dark	light
secular	divine
action	inspiration
rational	impulsive
square	circle
heavy	bouyant
body	soul

West

<u>Yin</u>	<u>Yang</u>
feminine	masculine
negative	positive
yielding	strong
follower	leader
light	dark
divine	secular
inspiration	action
impulsive	rational
circle	square
bouyant	heavy
soul	body"

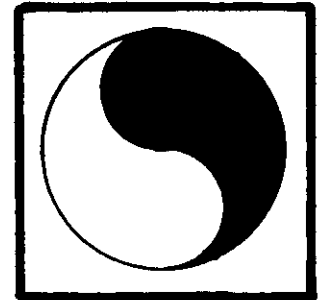

(Reifler, p. 6).

The Grid

The grid represents a rational order. It is centerless and extends infinitely. It is used to quantify and measure, but makes no hierarchy or focus. It symbolizes the rational, the scientific, the objective. Its presence is very minimal, if not non-existent in my project.

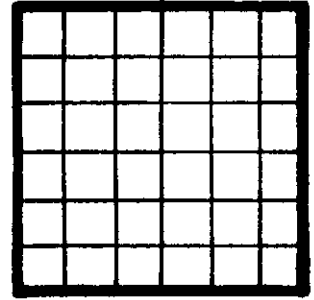

The Spiral

The spiral is a symbol for mortality. For me it also represents spiritual growth. The winding spiral revolves around the same center and moves in closer and closer. It is a finite path and thus not infinite like the circle. Spirals and vortexes are common forms throughout nature and religious symbolism.

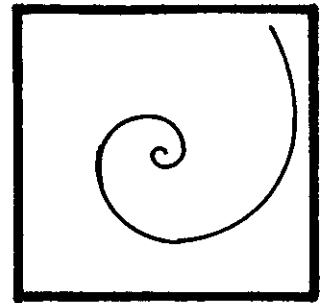

Water and Sky

Water symbolizes the soul, and is the primordial material from which everything arose. Water patterns are often used on the floor of sacred spaces to make reference to the powerful symbol of the water and also as a cosmological symbol.

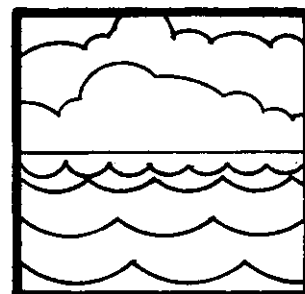

The ceilings of sacred places is often made to represent the sky. Myths involving the sky are often depicted here. The hierarchical structuring of the cosmos often places God in the sky.

The Nine Pointed Star

The number nine is sacred in the Baha'i Faith and the nine pointed star is its emblem.

"Nine is the number of the descent of the Divine power into the world. When the Angelus rings, it rings nine times." (Campbell, p. 27).

"Concerning the number nine: the Baha'is reverence this for two reasons, first because it is considered by those who are interested in numbers to be a sign of perfection. The second consideration which is the more important one is that it is the numerical value for the word 'Baha.' (B=2, h=5, a=1 and there is an accent at the end of the word which is also =1; the 'a' after the 'B' is not written in Persian so it does not count.) In the Semitic languages - both Arabic and Hebrew - every letter of the alphabet had a numerical value, so instead of using figures to denote numbers they used letters and compounds of letters. Thus every word had both a literal meaning and also a

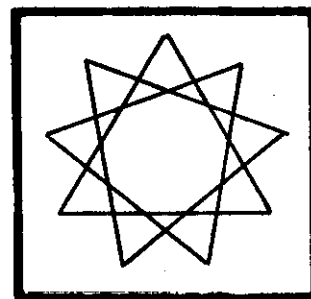

numerical value. ... As the baha also stood for the number nine, it could be used interchangeably with it.

"Besides these two significances the number nine has no other meaning. It is however enough to make the Baha'is use it when an arbitrary number is to be chosen." (Hornby, p. 311).

"The number nine which in itself is the number of perfection is considered by the Baha'is as sacred because it is symbolic of the perfection of the Baha'i Revelation which constitutes the ninth in the line of existing religions, the latest and the fullest Revelation which mankind has ever known. The eighth religion is the religion of the Bab, and the remaining seven are: Hinduism, Buddhism, Zoroastrianism, Judaism, Christianity, Islam, and the religion of the Sabeans. These religions are not the only true religions that have appeared in the world, but are the only ones still existing." (Hornby, p. 311).

The Greatest Name

"The Greatest Name should be found upon the lips in the first awakening moment of early dawn. It should be fed upon by constant use in daily invocation, in trouble, under opposition, and should be the last word breathed when the head rests upon the pillow at night. It is the name of comfort, protection, happiness, illumination, love and joy." (Hornby, p. 211).

"... the symbol of the Greatest Name represents an invocation which can be translated either as 'O Glory of Glories' or 'O Glory of the All-Glorious.' The word glory used in this connection is a translation of the Arabic term 'Baha'i,' the name of Baha'u'llah." (Hornby, p. 211).

"It should be pointed out that Baha'u'llah, Baha, Allah'u'Abha, Ya Baha'u'llah, the ringstone symbol, and the design in Arabic script are all correctly called the Greatest Name." (Hornby, p. 211).

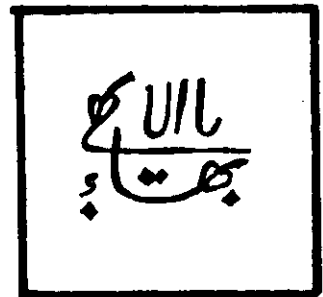

B. Translation

The Mandala and the Center were the two ideas that were critical to my project. The translation of these ideas into a physical design was the next step. I began to create a mandala of my personal conception of what a House of Worship should be. I began a layering process where I superimposed one symbol or archetype over another. When a size was required I used the step as a measurement, and the numbers nine, nineteen, and ninety-five as distances. By overlapping the symbols, a structure emerged that became not only a mandala form, but also a labyrinth. The labyrinth would exist for the people who visited this place, but the labyrinth was more present in my mind as I searched and struggled for a way to discover, order, express, shape, and sequence my ideas. I was on one level very rationally placing the symbols onto the site, but in the dissimilar geometry were unforeseen in-between spaces that were much more ambiguous and required connection to the other forms. With the attempt being to charge every form with symbolic and narrative meaning, the nature of the connection between these forms was problematic, and created unforeseen narratives. By searching within myself to discover the meanings of these connections, I discovered other relationships between the ideas I had first placed. After a time the forms began to order themselves and the numbers and geometry became quite precise and tight. The framework began to shape itself.

The following images are the sequence. As I placed each element into the mandala, I thought only of each as a form to itself, the spaces and connections between the symbols evolved with much more irrationality and chance.

The Design Sequence

1. I began with the Center, which would be an oculus which would hold the Greatest Name.



2. A Circle was the best form to mark the Center, and this became the boundary of the gardens.

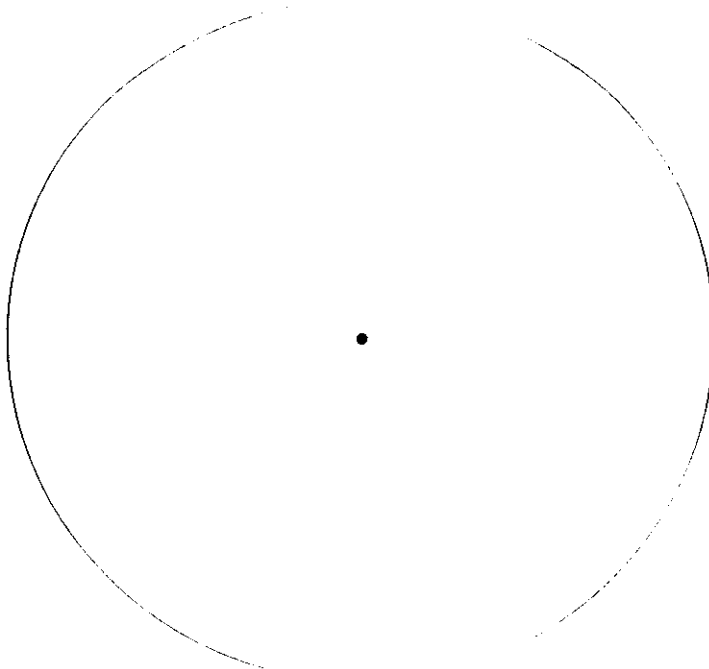

3. Nine entrances were given and to size the circle I spaced these entrances ninety-five steps apart.

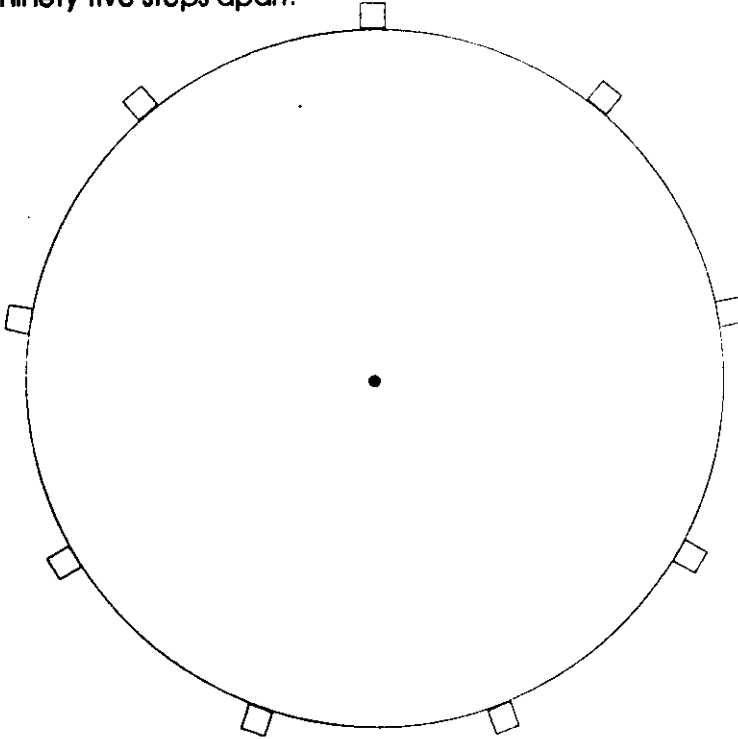

4. I drew another circle to indicate the boundaries of the House of Worship. I place the circumference ninety-five steps from the outer circle.

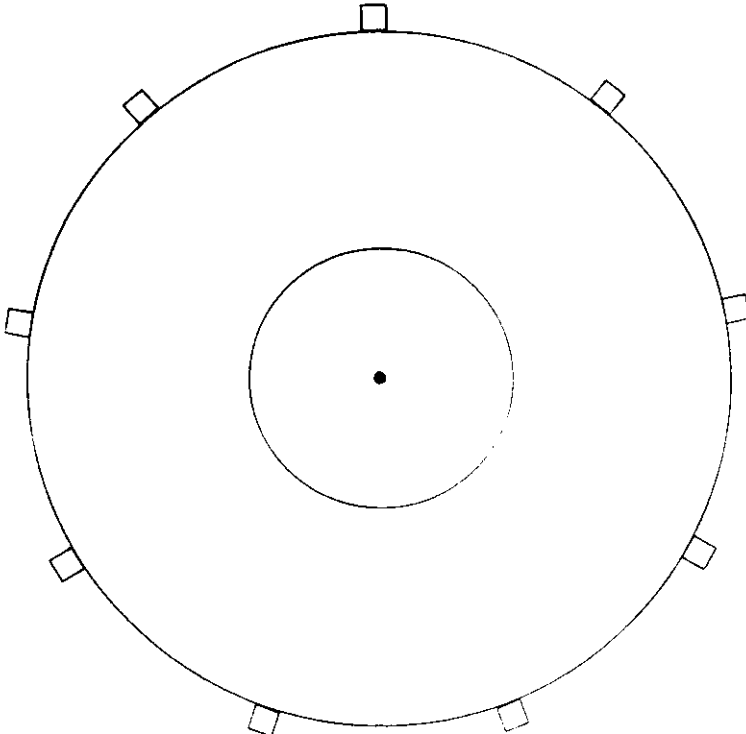

5. From the edge of this circle there are nine steps to the platform of the House of Worship.

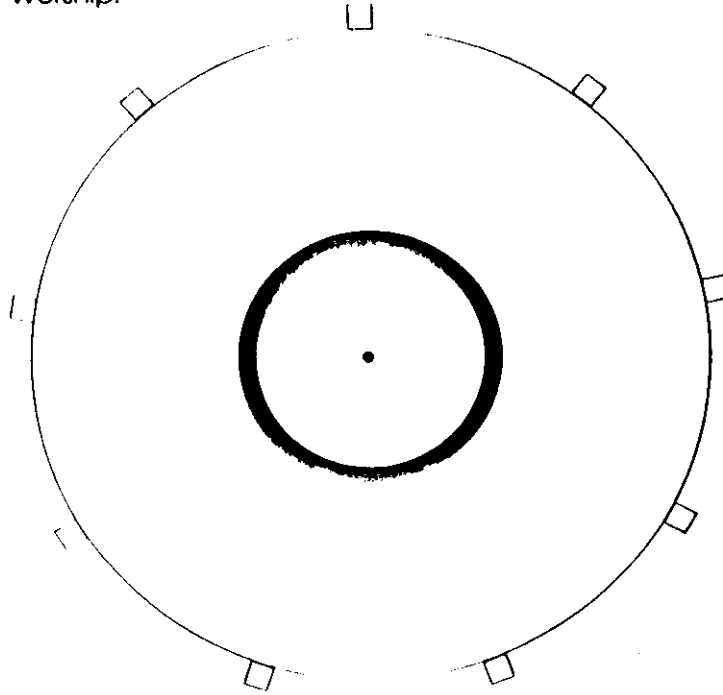

6. I marked the Cardinal Points with the symbol for the earth.

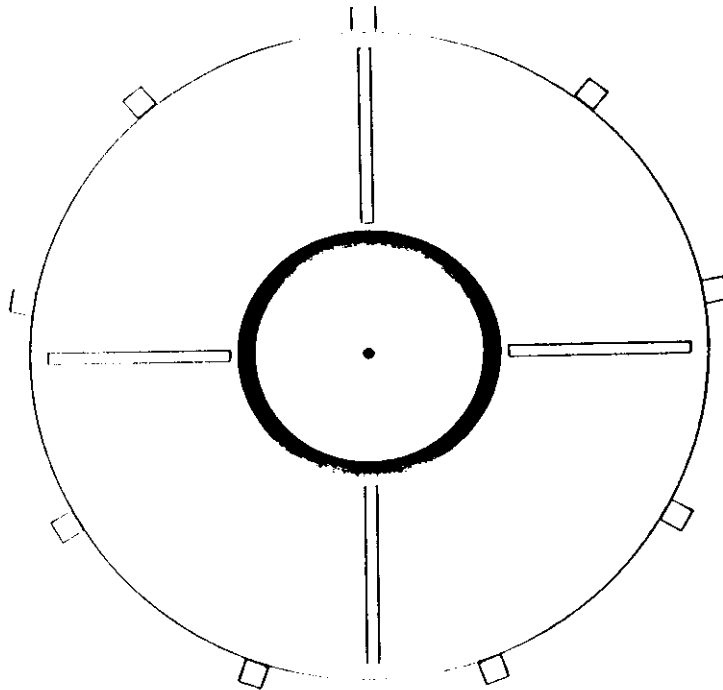

7. I made a Yin / Yang upon the site to mark duality.

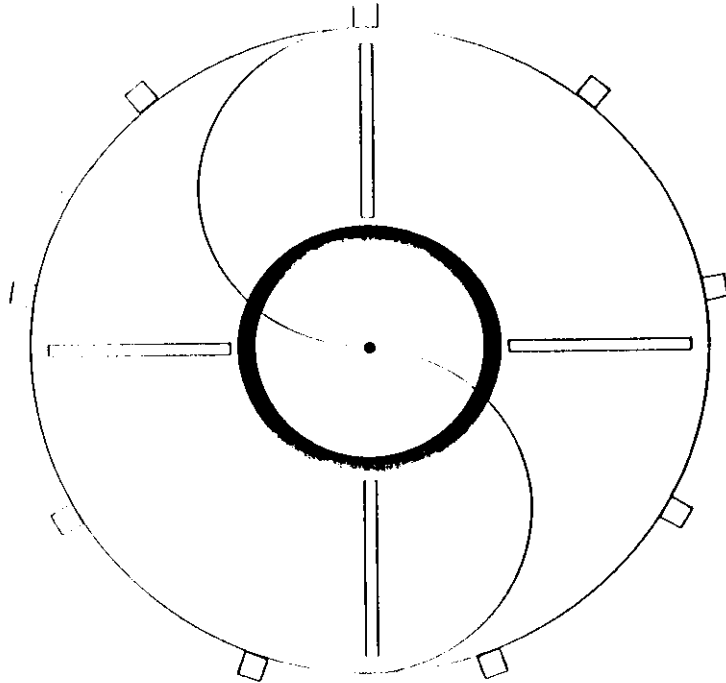

8. I drew a spiral of mortality, which later became a winding spiral, rather than a logarithmic spiral.

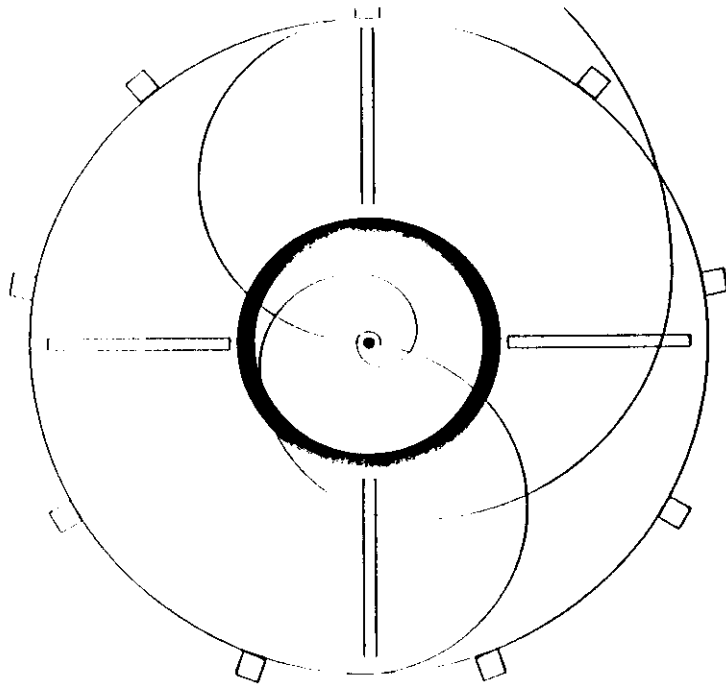

9. I inscribed a nine pointed star on the House of Worship platform.

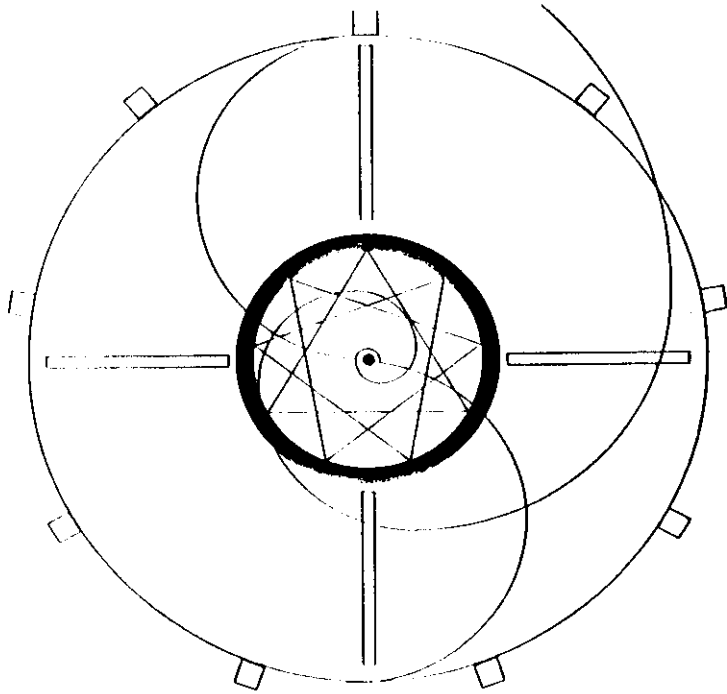

10. I created another circle for an ambulatory nineteen steps from the top step of the platform.

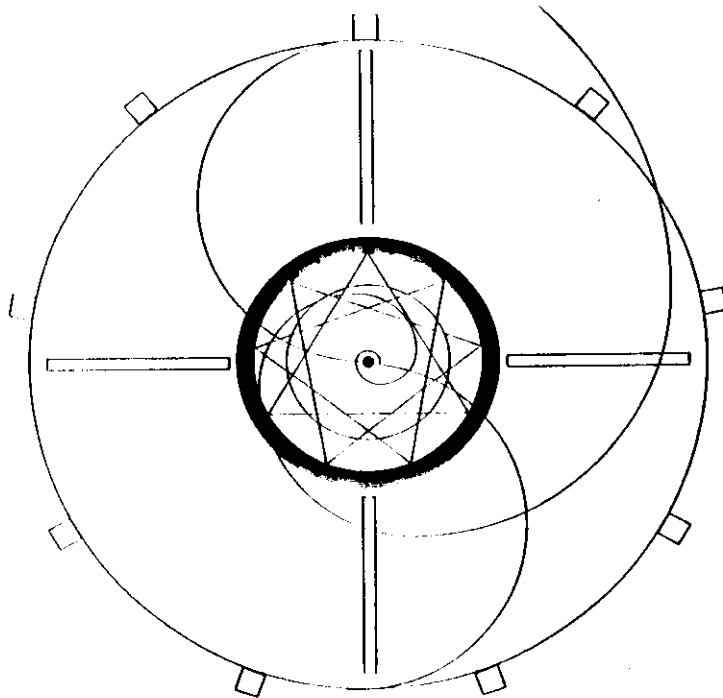

11. I squared this circle and oriented it to the Baha'i World Center in Haifa, Israel.

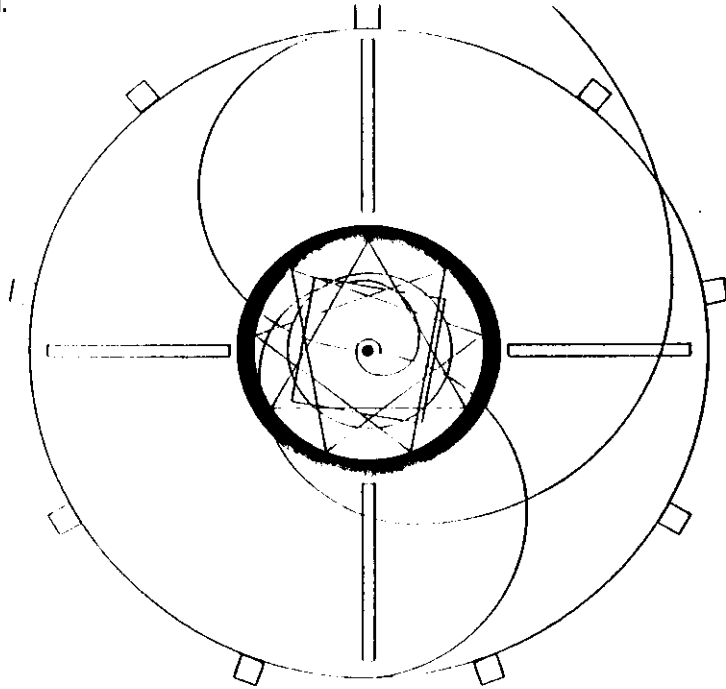

12. I then created the inner auditorium under the dome by drawing another circle nine steps across the ambulatory.

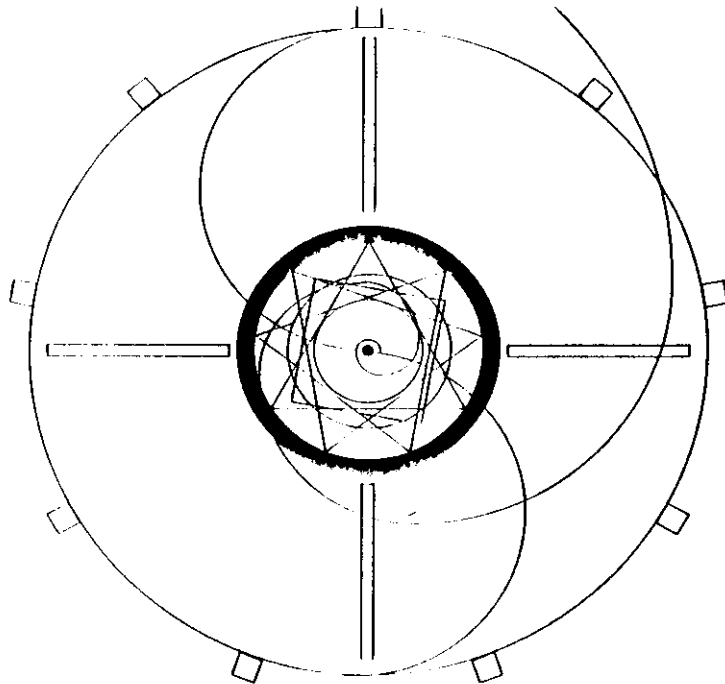

13. I let the starsunburst into another star to let the energy expand out into the gardens, and later let that expand out of the gardens into the world.

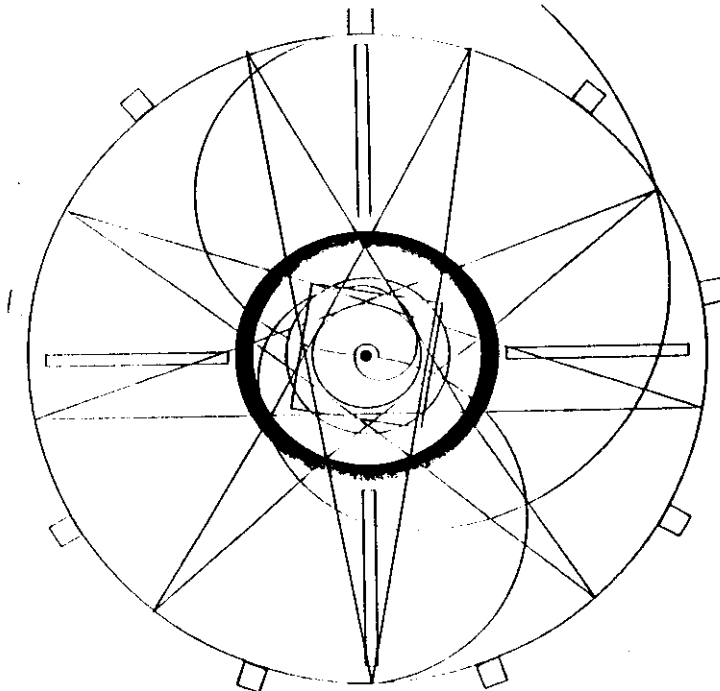

From this framework, I began to discover the narratives between the forms, and found that my original concept from the first process would still apply to this richer framework.

What became important for me were two of the many ways of perceiving the design. One would be through the pedestrian approaches through the nine entrances. The second way of perceiving the symbols I considered was more labyrinthine. As the visitors would move around the site, the large scale order would become apparent on a more cerebral level. Through this exploration over time and assimilation of all the gardens and the House of Worship, the philosophical and conceptual cosmology of the Mashriqu'l-Adhkar becomes apparent.

The sequence of the symbol forms and the garden narratives encountered were intended to convey a meaning or idea that could

C. The Stories

Baha's must say one of three obligatory prayers a day. They are all centering prayers that establish the essential relationship between man and God. The Short Obligatory prayer requires that one turn toward the shrines in Haifa Israel and say:

"I bear witness, O my God, that Thou hast created me to know Thee and to worship Thee. I testify, at this moment, to my powerlessness and to Thy might, to my poverty and to Thy wealth.

There is none other God but Thee, the Help in Peril, the Self-Subsisting."

be related to the Baha'i Faith. I then returned to my original garden ideas. With each garden having different moments of the large symbols, each would be a different site for a different narrative. I was able to design one of them before my time ran out.

"O Man of Two Visions!
Close one eye and open the
other. Close one to the world
and all that is therein, and
open the other to the hal-
lowed beauty of the Be-
loved." (Baha'u'llah, Hidden
Words, p. 56).

The example story I was able to design begins outside the Garden of Consultation:

As the Visitor walks around the circumference, they move along a curved path, guided by a Center that is concealed by a tall wall of stone. As the Visitor chants the Greatest Name as they walk, it becomes a prayer expressing their desire to be spiritually centered, to be near God, to have the veil (the wall) removed and opened. They are calling the Name of the One they seek.

The Visitor comes upon two entrances. From the other direction on the circular path arrives some one with whom he has a conflict on a certain issue. They each pass into the garden on opposite sides of a wall which is part of a larger figure representing the Earth. The wall therefore is the earthly concern or issue that has become a barrier to their friendship, interaction, and spiritual growth. They indicate their desire to resolve the issue by progressing along the wall toward the Center. They are offered a chance to move into the issue and walk together - viewing both sides of the issue - to the Chamber of Consultation; to engage the issue from within and come to a unified, peaceful resolution.

If they do not choose to come together, they are pushed farther and farther apart from each other and the issue. They then encounter the spiral of mortality, which shows them their mutual humanity as a request for humility. It is the last chance to choose to enter the Chamber of Consultation, or show pride and drift farther apart and eventually lose all footing. The House of Worship cannot be approached from this path. In the Writings some where it is said: That if

two people are arguing a point of religion, then both are wrong.

If the issue is resolved through consultation, the Visitor and his Friend move out into the rest of the Garden where the wall lifts from between them, arcing toward the Center. If the issue is not resolved, the Visitor and his Friend stay within the wall and rise to the House of Worship (which will also be known as the House of Justice). The approach provides a low perspective up to the nine steps as a view from a humble station. They appeal to the higher authority of the National Assembly or even God.

This is not intended to be an actual ritual that takes place here, but a model of an idea that can be experienced didactically. Other stories would be developed in the other eight gardens.

The following drawings were originally three feet square, and along with two models (shown in the photographs) and a series of smaller drawings constituted my presentation for the thesis jury.

*O Son of Spirit!
The best beloved of all things
in My sight is Justice; turn not
away therefrom if thou
desirest Me, and neglect it
not that I may confide in thee.
By its aid thou shalt see with
thine own eyes and not
through the eyes of others,
and thou shalt know of thine
own knowledge and not
through the knowledge of thy
neighbor. Ponder this in thy
heart; how it behoveth thee
to be. Verily Justice is My gift
to thee and the sign of My
loving-kindness. Set it then
before thine eyes.*
(Baha'u'llah, Hidden Words,
p. 9).

D. The Drawings

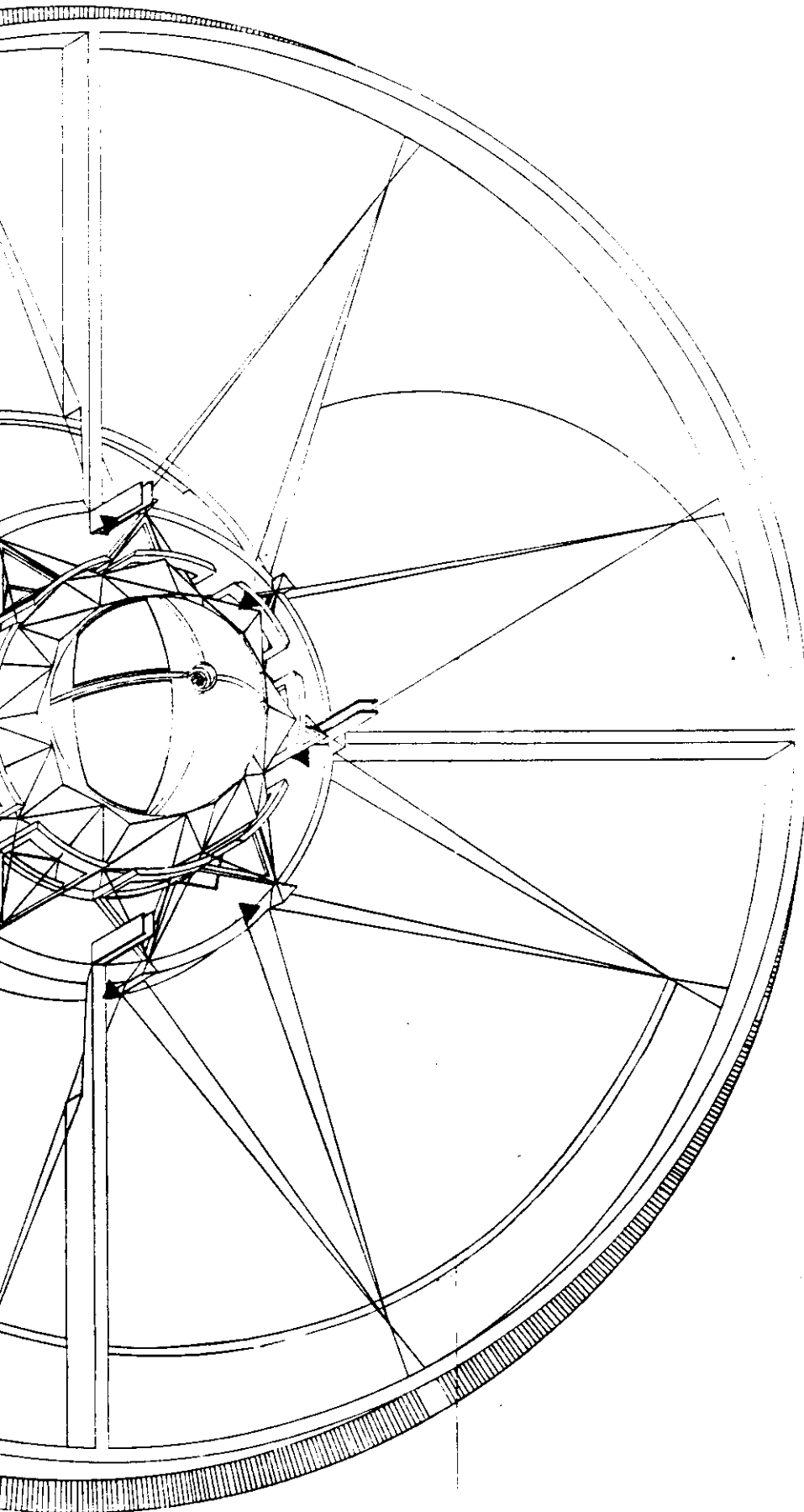

The Site Plan

"As the pigments are but the vehicle of painting, so is building but the vehicle of architecture, which is the thought behind form, embodied and realized for the purpose of its manifestation and transmission. Architecture then, interpenetrates building, not for satisfaction of simple needs of the body, but the complex ones of the intellect. ... Architecture and building are quite clear and distinct as Ideas - the soul and the body." (Lethaby, pp. 1-2).

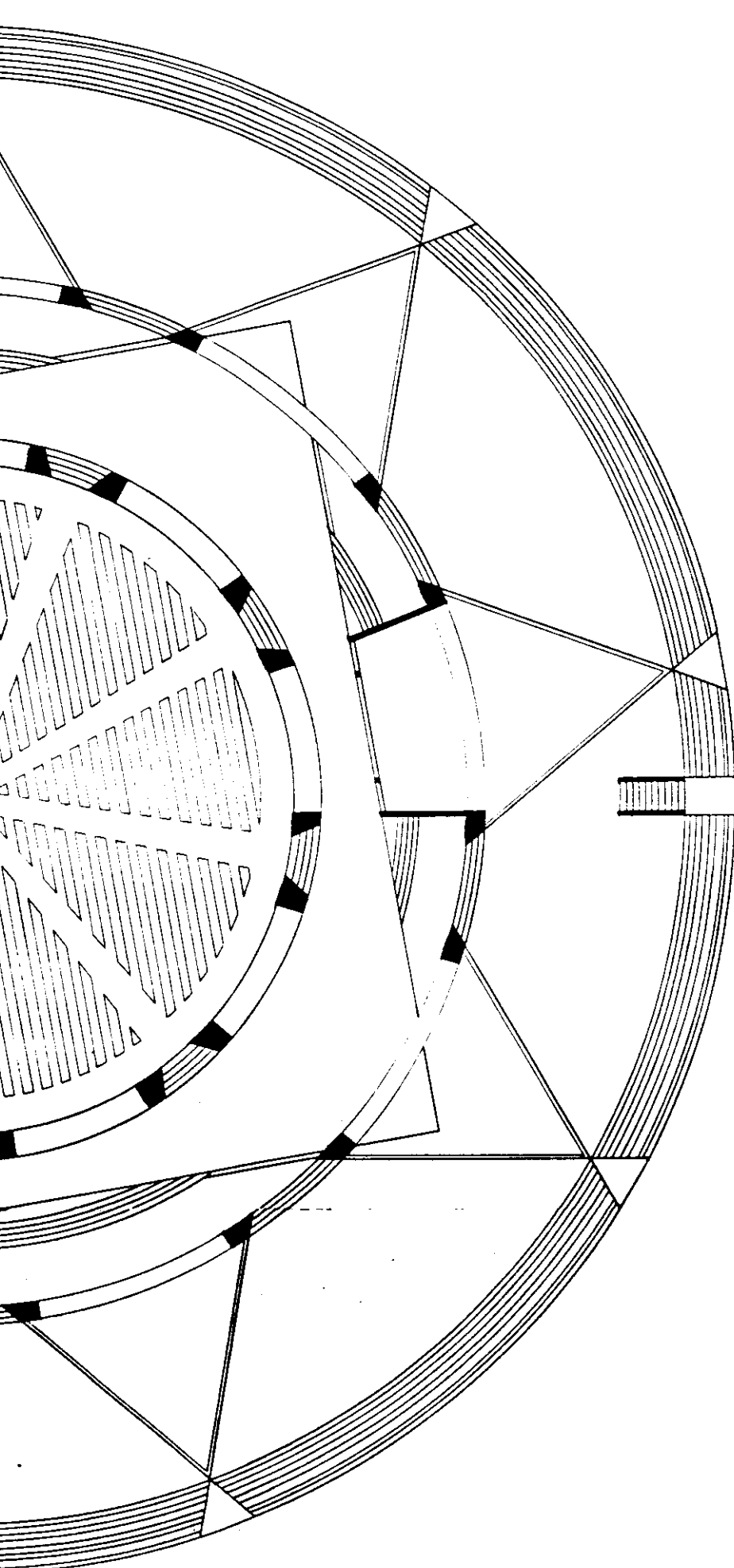

The House of Worship

"A temple is a landscape of the soul. When you walk into a cathedral, you move into a world of spiritual images. It is the mother womb of your spiritual life - the mother church. All forms around are of significant spiritual value." (Campbell, p. 80).

An abstract graphic design featuring a large, curved, black band that sweeps across the page from the top left towards the bottom right. This band is flanked by several thin, parallel lines that also curve in the same direction. In the lower-left quadrant, there is a series of nested, concentric, curved lines that create a sense of depth and movement. The overall composition is minimalist and geometric.

The Garden of
Consultation

forty-eight

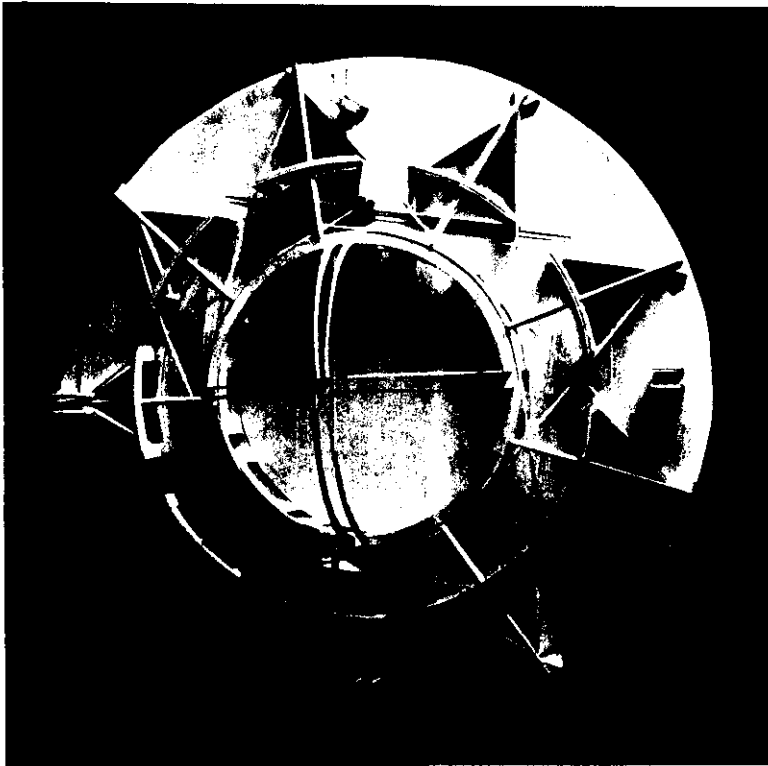

House of Worship Photographs

"Unity and totality stand at the highest point on the scale of objective values, because their symbols can no longer be distinguished from the *Imago Dei*. Hence all statements about the God-Image apply also to the empirical symbols of totality." (Jung, p. 229)

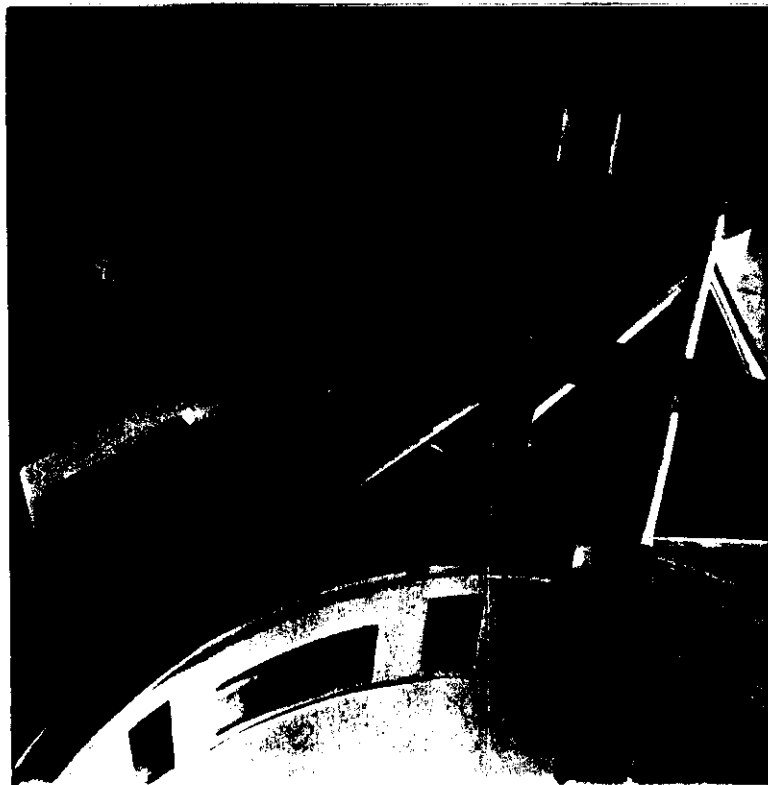

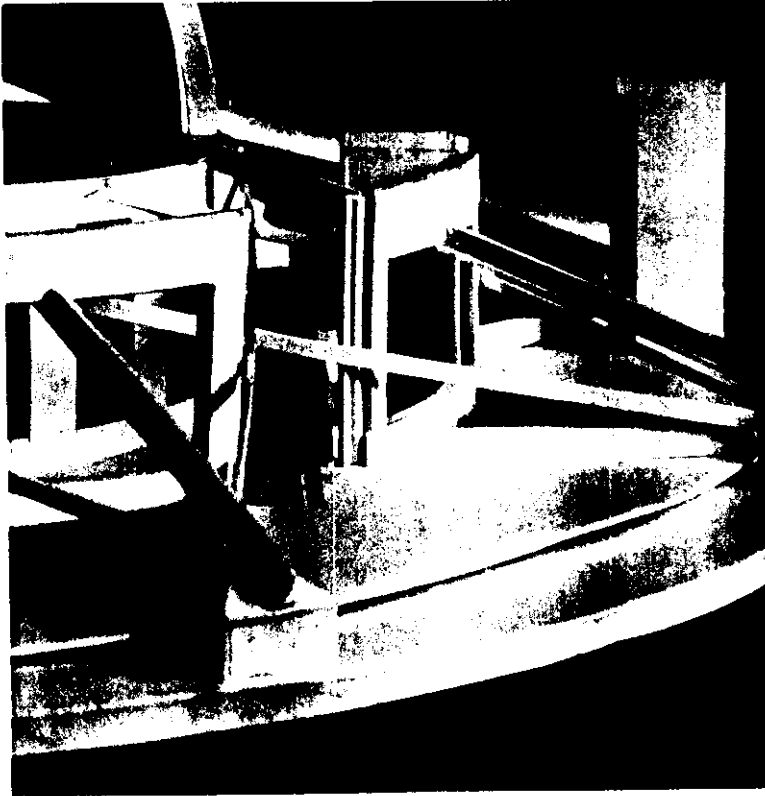

House of Worship Photographs

"The idea that the pure regularities of geometry lie at the basis of thought and of the structure of the universe is deep in our cultural heritage." (Mackay, p. 68).

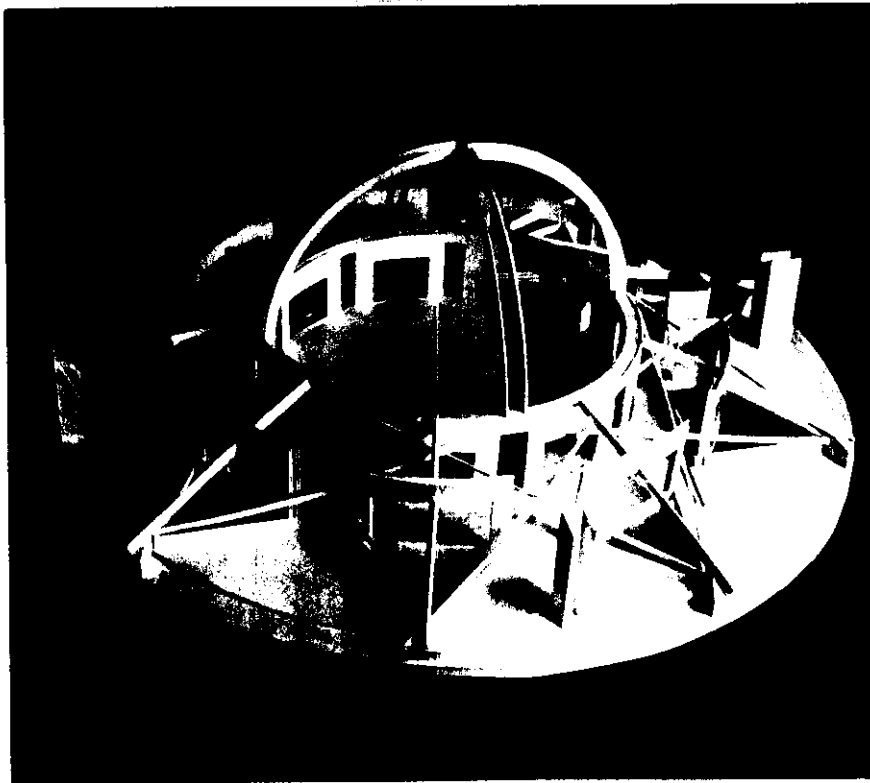

**G a r d e n o f
C o n s u l t a t i o n
P h o t o g r a p h s**

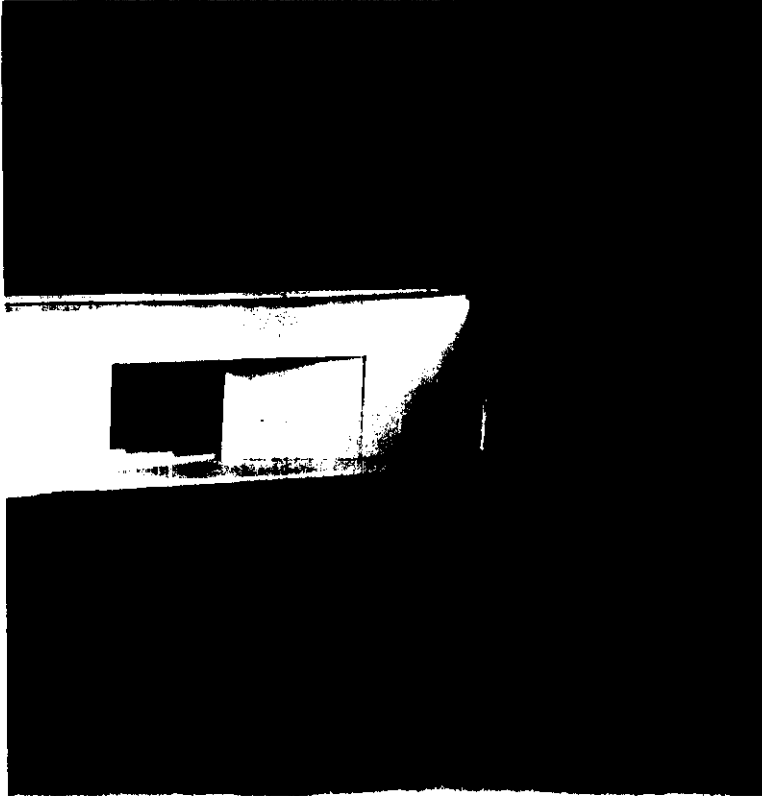

Garden of
Consultation
Photographs

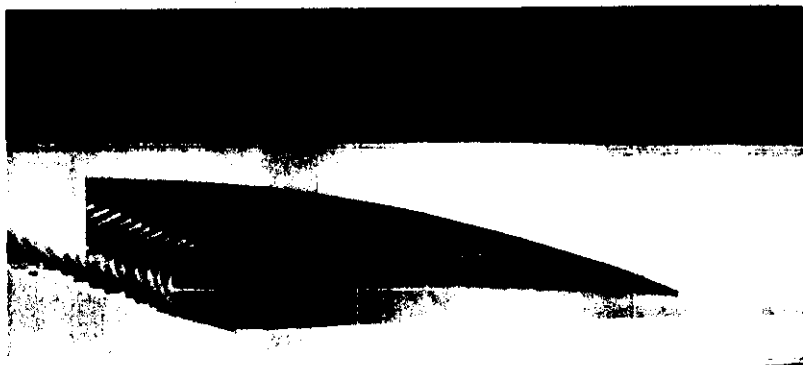

The material quoted below is from a book titled: From Temple to Meeting House: The Phenomenology of Places of Worship. This is a book that would have helped me tremendously, had I been able to use it prior to and during design. However, it may also be useful now as a guide for me to look back through what I have done in order to reflect and evaluate.

"We need a theology of space itself, as a basic category or dimension of human existence with the most immediate relevance to a spatial structure..." (Turner, p. 6).

"The space in which human life is set is far from being homogeneous in our experience. Only in a world 'without form and void' could one space be the same as another, and then all space would be equally meaningless to us. Spaces, or the different places within space, have meaning and value only because of the different organization and content they contain, which mark them out from one another. Among the many differentiations those with the greatest meaning and value are distinguished from the more ordinary places through their association with supra-human powers or presences." (Turner, p. 13).

Both the meeting between men and the gods, and the language men use to the gods and about them are inevitably involved in spatial references, so that in examining the sacred place of meeting we are dealing with a basic category of religion. That it is basic is indicated perhaps by the tremendous variety of spatial forms that the sacred place may adopt: stones singly or in circles, grottoes and groves, trees, pillars and mountains, springs, rivers and seas, altars, shrines and sanctuaries, temples, tabernacles, synagogues, churches, stupas and mosques, places of pilgrimage where divine actions have been

recorded or holy men are buried, sacred cities and holy lands." (Turner, p. 14).

"There is the first idea that all space is organized and oriented by the sacred place, itself regarded as the centre of man's life, the point of reference around which the world is built, or, as it is vividly put in a number of traditions, the navel of the earth. From this point men take their bearings and establish some system and meaning in human existence; at the sacred place life finds its centre of unity and ceases to be merely a chaotic flow of experiences.

"This functioning as the ultimate centre for human affairs derives from a second characteristic structure found in the sacred place, its capacity to mirror or to represent on earth a more perfect and ultimate realm conceived as lying beyond the terrestrial domain." (Turner, pp. 9 - 10).

"...the sacred place is the one place on earth fit for the gods to visit, where they may be encountered with certainty by men, and where the heavenly and earthly realms continue to intersect." (Turner, p. 10).

"A third characteristic form is the cult object, image or idol that symbolizes and embodies the divine presence at the sacred place. It may be almost anything - an unshaped stone, a wooden pole, an empty throne, an elaborate metal image, or even a mirror or a written document. Whatever it is represents the very complex notion implicit also in the previous two structures, that while the gods are really to be met at this place they cannot be contained in it, that while they are truly immanent in this sacred object they are just as truly transcendent and beyond it in their own proper realms. Indeed, this may be regarded as the basic endeavor of all sacred places, to guarantee the immanent divine presence of divine beings who by their very nature transcend all such places; and what is this but the basic

problem of the relation of man to his gods?" (Turner, p. 10).

"(Examples of the experience of being lost) indicate how basic is some centre of reference for life as a person in what we call a 'world' - some organized system which supplies meaning and direction for our actions, some point from which we take our bearings and make sense of it all. Without this life is a senseless flux of events and degenerates into chaos. Value systems, world views, ideologies, philosophies of life as well as the more physical orientation to our material environment through sight, hearing, movement and memory are essential to existence as a man, and all of these imply some centre of reference." (Turner, p. 19).

"Such a centre of reference is found in the sacred place where contact may be made with a much more real and solid world than that of every day uncertain and changing experience. The transient and vulnerable affairs of men then have an 'anchor in the ultimate.'" (Turner, pp. 19 - 20).

"Of the 'entrance' phenomena we may begin with the significance of the threshold. ... There must be a particular place of entrance and to cross the threshold at this point is a momentous act for it marks the transition from the everyday natural order to the place of divine power and presence that lies beyond, within the precinct. In consequence, a host of religious practices are concerned in one way or another with the protection or the crossing of the threshold." (Turner, p. 22).

"...the heavenly realm must be fit for the gods' presence. It is, as it were, a little piece of heaven on earth, or at least it corresponds to the heavenly original as an earthly replica, a mirror of its model, or a microcosm of the cosmos as a whole. The theme of earth and heaven being corresponding realities, existing in mutual relationship, with the sanctuary as the particular point of connection and similarity,

finds many expressions." (Turner, p. 26).

"As the sacred place becomes elaborated with formal enclosures, shrine buildings and their cultic objects, and finally the whole complex of courts and entrances and temple buildings, it remains important that all such development should continue to be patterned on the heavenly model." (Turner, p. 28).

"The sacred place is therefore one of the most complex developments in human history, rich with meaning and of many functions, the centre of reference from which all else is orientated (sic) .. understood, or valued and on which it should be patterned, the one ordered place in a disordered world, the source of life's meaning and the anchor that gives security, the rendezvous between the human and the divine where the two worlds intersect and the gods and men may meet." (Turner, p. 33).

After finishing the book I feel much more positively about the thesis. I felt frustrated toward the end of preparing my presentation as I knew that I would not complete the presentation, that my design could be still a much deeper translation and exploration of the re - search, and that I could have been much more expressive within the format of the presentation itself. Now, having it all together, telling the whole story, and sharing the wonderful words I found in the books, I feel like I can step back and let it soak for awhile before continuing to dig deeper into the knowledge that is out there, and within myself to create. As scary as it was, I am glad I stepped away from my first process and studied the sacred, symbols, myths, and religion. I feel like I am in a much better position to pursue this into other projects and my own experiences in sacred places.

On completing the *Masks of God* series, Joseph Campbell wrote:

"Looking back today over the twelve delightful years that I spent on this richly rewarding enterprise, I find that its main result for me has been its confirmation of a thought I have long and faithfully entertained: of the unity of the race of man, which has not only in its biology, but also in its spiritual history, which has everywhere unfolded in a manner of a single symphony, with its themes an

B . E p i l o g u e

nounced, developed, amplified, and turned about, distorted, reasserted, and today, in a grand fortissimo of all sections sounding together, irresistibly advanced to some kind of mighty climax, out of which the next great movement will emerge."

VI. Bibliography

Arguelles, Jose and Miriam. Mandala. Boston: Shambhala Publications, Inc., 1972.

Baha' u' llah. The Hidden Words of Baha' u' llah. Trans. Shoghi Effendi. London: Oneworld Publications Ltd., 1986.

Baha' u' llah. The Seven Valleys and the Four Valleys. Trans. Marzieh Gail. Wilmette, IL: 1945.

Burckhardt, Titus. "The Symbolism of Water," In Mirror of the Intellect. Trans. and Ed. by William Stoddart. Albany, NY: State University of New York, 1987, pp. 124 - 131.

Also "Traditional Cosmology and Modern Science," In Mirror of the Intellect. pp. 17 - 67.

Campbell, Joseph. The Power of Myth. Ed. Betty Sue Flowers. New York: Bantam Doubleday Dell Publishing Group, Inc., 1988.

Eliade, Mircea. Ordeal by Labyrinth. Chicago: The University of Chicago Press, Inc., 1972.

Franz, N. -L. von. "The Process of Individuation," In Man and His Symbols. Ed. Carl Jung. New York: Dell Publishing Co., Inc., 1964, pp. 95 - 156.

Hornby, Helen. Lights of Guidance. New Delhi, India: Baha'i Publishing Trust, 1983.

Jaffe, Aniela. "Symbolism in the Visual Arts," In Man and his Symbols. Ed. Carl Jung. New York: Dell Publishing Co., Inc., 1964, pp. 255 - 322.

Jung, Carl. The Essential Jung. Ed. Anthony Storr. Princeton, NJ: Princeton University Press, 1983.

Kelsey, Morton T. Myth, History and Faith. New York: Paulist Press, 1974.

Lethaby, W. R. Architecture, Mysticism, and Myth. New York: George Braziller, Inc., 1974.

Mackay, Alan. "Mandala Thinking." In Radical Currents in Contemporary Philosophy. Ed. David DeGroot, Dale Riepe, and John Sommerville. St Louis: Warren H. Green, Inc., 1971. P. 67.

Martin, F. David. Art and the Religious experience: The "Language" of the Sacred. Cranbury, NJ: Associated University Presses, Inc., 1972.

Munar, Bruno. The Discovery of the Circle. New York: George Wittenborn, Inc., 1966.

Reifler, Sam. I Ching. New York: Bantam Books, 1974.

Whitmore, Bruce. The Dawning Place. Wilmette, IL: Baha'i Publishing Trust, 1984.

The following is a quote from an appendix in Bruce Whitmore's book The Dawning Place, which is about the construction of the House of Worship in Chicago. I use it to explain briefly a bit about the Baha'i Faith.

"The Baha'i Faith, an independent world religion, was founded by Mirza Husayn 'Ali (1817 - 1892), known as Baha'u'llah, the 'Glory of God.' The Baha'i Faith's origins are intimately linked with the Babi faith, founded in Persia (Iran) in 1844 by Mirza 'Ali Muhammad (1819 - 1850), known as the Bab, or 'Gate.' The Bab announced that He was not only the founder of an independent religion, but the herald of a new and far greater prophet or messenger of God, Who would usher in an age of peace for all mankind. In 1863 Baha'u'llah declared that He was the One prophesied by the Bab.

Baha'u'llah's teachings quickly brought Him into conflict with the Persian government and the Muslim clergy, and he was exiled from Iran to various places within the Ottoman Empire. In 1868 He was sent as a prisoner to the fortress city of Akka in the Holy Land, in the vicinity of which he passed away in 1892. In His will, He appointed 'Abdu'l-Baha (1844 - 1921), His eldest son, to succeed Him in leading the Baha'i community and in interpreting the Baha' writings. 'Abdu'l-Baha in turn appointed His eldest grandson, Shoghi Effendi (1897 - 1957), as His successor, the Guardian of the Cause and authorized interpreter of the Baha'i teachings. Today the affairs of the Baha'i world community are administered by the Universal House of Justice, the supreme elected council of the Baha'i Faith.

The central teachings of the Baha'i Faith are the oneness of God, the oneness of religion, and the oneness of mankind. The fundamental

principles proclaimed by Baha'u'llah are that religious truth is not absolute but relative; that Divine Revelation is a continuous and progressive process; that all great religions of the world are divine in origin; and that their missions represent successive stages in the spiritual evolution of human society. Since Baha'u'llah teaches that the purpose of religion is the promotion of concord and unity and that religion is the foremost agency for the achievement of peace and orderly progress in society, The Baha'i writings provide the outline of institutions necessary for the establishment of peace and world order. These include a world federation or commonwealth, with executive, legislative, and judiciary arms; an international auxiliary language; a world economy; a mechanism for world intercommunication; and a universal system of currency, weights, and measures.

The Baha'i writings also provide specific guidance that helps Baha'is (followers of Baha'u'llah) fulfill the basic purpose of human life - knowing and worshiping God and 'carrying forth an ever-advancing civilization' - while they strive to bring about the unity of mankind, world peace, and world order. For example, the Baha'i writings call for the fostering of a good character and the development of spiritual qualities such as honesty, trustworthiness, compassion, and justice. These are achieved through prayer, meditation, and work done in the spirit of service to humanity - all expressions, for Baha'is, of the worship of God. In the pursuance of the Baha'i principle of the organic oneness of humanity, the Baha'i writings call for the eradication of the prejudices of race, creed, class, nationality, and sex. They call for the systematic elimination of all forms of superstition hampering human progress and the achievement of a balance between the material and the spiritual aspects of life, both of which rest on an understanding of the principles of the unfettered search for truth and of the harmony of science and religion as two facets of truth. They encourage the development of the unique talents and abilities of every individual, through the pursuit of knowledge and the acquisition of skills; for the practice of a trade or profession is required not only

for personal satisfaction but also for the enrichment of society as a whole. They call for the full participation both of men and women in all aspect of community life, including the elective and administrative processes and decision making, in implementation of the Baha'i principle of equal opportunities, rights, and privileges for both sexes. They call for the fostering of the principle of universal compulsory education." (Whitmore, pp. 245 - 246).

Appendix II.

The paper I mentioned writing for my Theory / Method class is relevant to my thesis and I thought it should be included. It follows in the next pages as I presented it for class.

Kenneth Sewell
THE CENTER IN ARCHITECTURE
From Theism to Nihilism

Abstract

Expressing the sacred nature of life, the Center in architecture is a prime symbol of the Divine, which has manifested in the art and architecture of many cultures, and religions. In the past, the theistic cosmology and philosophy formed a basis for living with art and architecture a natural extension, because architecture has always been representative of the values and attitudes of the people who built it. In places like Stonehenge, the Pantheon, and Chartres, a powerful understanding of the Center is present for cultures that clearly understood their spiritual and mythological image of the world. Coming into the Modern era, the world changed so drastically that all previous ideas about the world and theology had to be reexamined and much of it was discarded. A shift away from the Center becomes increasingly apparent as the disillusionment turns to nihilism. At the turn of the century the grid came to represent an atheistic rationalism. Presently even rationalism has been called into question and the grid has also been vanishing into complex, fragmented, and de-centered spaces. Architects like Ludwig Mies van der Rohe, Peter Eisenman, and Thom Mayne have all experienced a problem with the Center that has effected their architecture. Louis Kahn has somehow maintained his Center, and was one of the few modern architects who continued with centered and symmetrical space. A symbol for search and struggle for meaning and Center is the labyrinth, which seems to be somewhat appropriate for much of today's current architecture. The labyrinth is a symbol that describes not only the physical object of architecture, but the mental processes of its construction, and consequently the state of the culture that it is built within.

Kenneth Sewell
THE CENTER IN ARCHITECTURE
From Theism to Nihilism

"No matter how civilized we become, we must still answer for ourselves the basic question of self-orientation, and in this respect, our condition today is no different than that of our first ancestors stepping out of the forest into the light."¹

"Walk to the well
Turn as the earth and moon turn
Circling what they love
Whatever circles comes from the Center."
- Rumi
Unseen Rain

The most primal symbol is the Circle which contains and is generated by the sacred Center. Jose Arguelles, who has done extensive research on sacred mandalas and also the Center, writes about the metaphysical and mythical power this symbol exerts:

"The circle is the original sign, the prime symbol of the nothing and the all; the symbol of heaven and the solar eye, the all encompassing form beyond and through which man finds and loses himself."²

The Circle, and therefore the Center, symbolize the Divine, the eternal, the whole, the sacred, the all surrounding and encompassing, the beginningless and the endless by acting as the structure for pulling these qualities into human life. An ancient proverb says, "God is a Circle whose Center is everywhere, but whose Circumference is nowhere."³ The Center then becomes the connection to the sacred with the circle (or other 'surrounding' forms) becoming the symbol, sign, or structure that marks the Center.

In space the Center is the place or point that connects man to the Divine, because it is the focus, the most important point which establishes the *locus* of all energy. While discussing the Center's role in cosmological symbolism, Jose Arguelles relates it to the Mind of God, an eternal source of energy generating seeds and the nuclei of cells and atoms.⁴ The instinctual need for centeredness or 'at-oneness' with the sacred is a manifestation of the soul's need for a spiritual existence, expression, and growth. That circular or centered forms find a way into our art and architecture reflects our mythological images and stories of the world and of God, and thus become intertwined and embedded with our psyche's relationship with the sacred.⁵ Discussing the translation of the need for centeredness, Arguelles writes:

"Feeling the impulse towards wholeness, man applies it to all that he does. It motivates his thoughts, permeates his activities, and resides in all that he constructs in his dwellings, as in those of most of the 'primitive,' pre-industrial world, there is a place, an altar, a fire, a stone that is the center, not only of the house or dwelling, but

also of the entire cosmos. This is no inherent contradiction, for we are dealing with what is essentially a *sacred* principle, or sacred state of consciousness in which all beings and all things are realized equally as emanations of One Divine Whole.⁷⁶

The inhabitation of centered, sacred space, be it within a circle, a cube, or a complex set of symmetries, yields a numinous experience for the theistic person. The physically focused space resonates spiritually and brings man into contact with the realm of the Divine by generating, embodying, and preserving the spiritually ontological force that these structures and symbols evoke.⁷⁷

In the great sacred architecture of the past, from Stonehenge to Chartres, an intense presence of the sacred Center was always vital to the structure of the place, the rituals which took place within it, and the theology, cosmology, or philosophy of the culture the architecture embodied. The cathedrals, mosques, and temples built before and through the Fifteenth Century are the densest attempts by various civilizations to consciously embody their beliefs in a meaningful, symbolic, mythical, and centered architecture.⁷⁸

At various moments in history a spiritual movement would reach a highpoint of enlightenment and would express this sentiment through their art and architecture. The following buildings and places are examples of highly centered architecture. Though most of the buildings shown are large stone buildings of Western christianity or pantheistic pagan systems, the idea of the Center can be found in temples of nearly all the world's great religions, including those of the Eastern tradition such as Buddhism and Hinduism. The selection shown here is some the great examples of ancient architecture and represent a sampling of the effort to honor the Center.

Stonehenge

An incredibly ancient example of a culture orienting itself the Center and also using the sun and moon to mark time.
(Images from Trachtenberg).

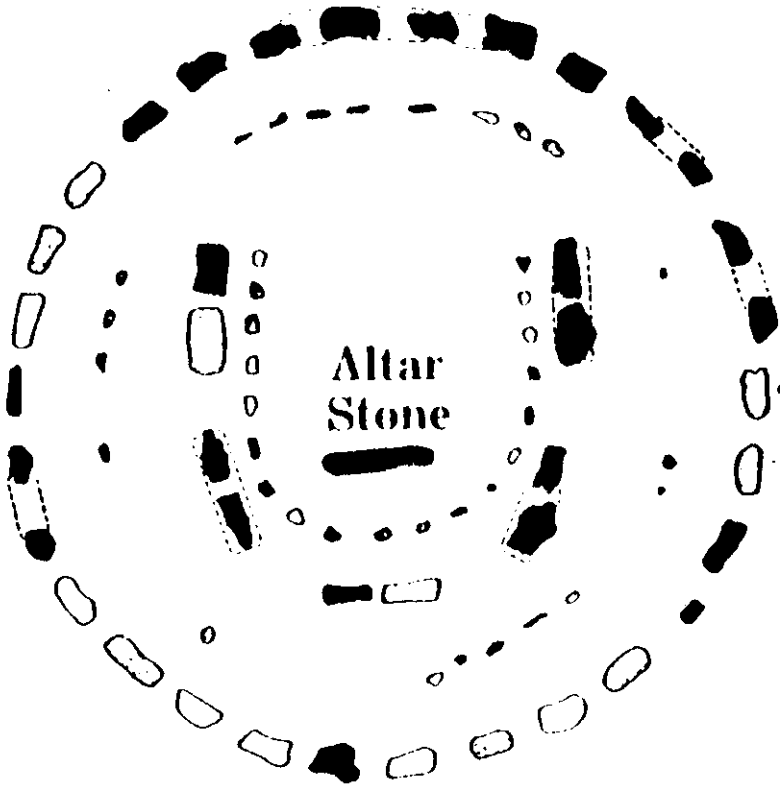

The Parthenon

Uses a rectangular volume and symmetry to surround and enshrine the Center and the Goddess who resided there.
(Images from Trachtenberg).

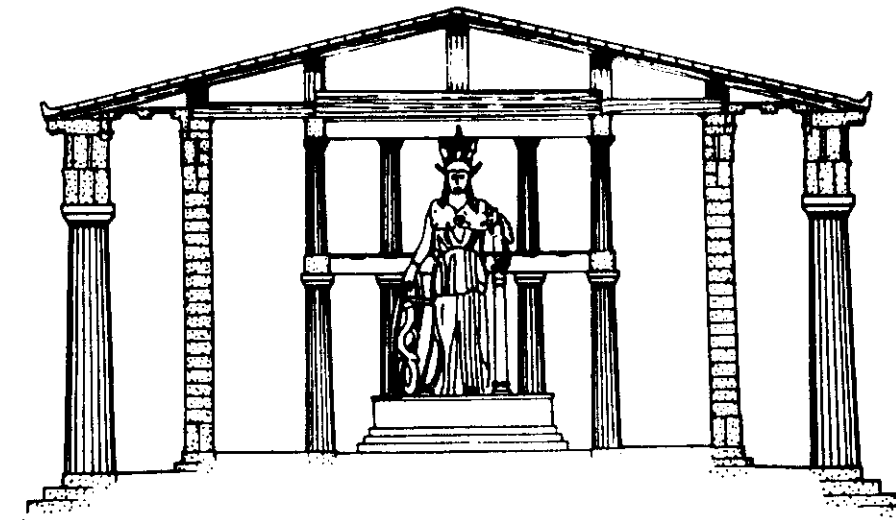
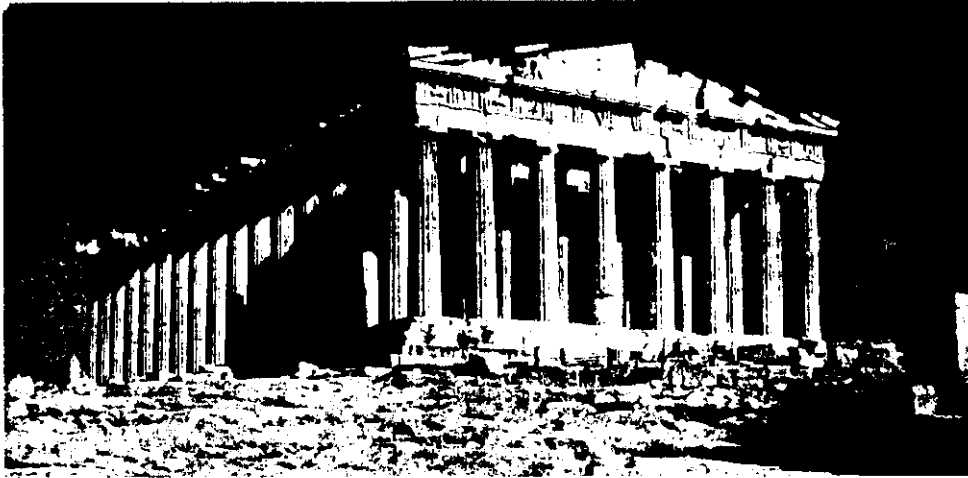

The Pantheon

A highly sophisticated and ordered spherical space that was dedicated to many gods and the Emperor.
(Images from Trachtenberg).

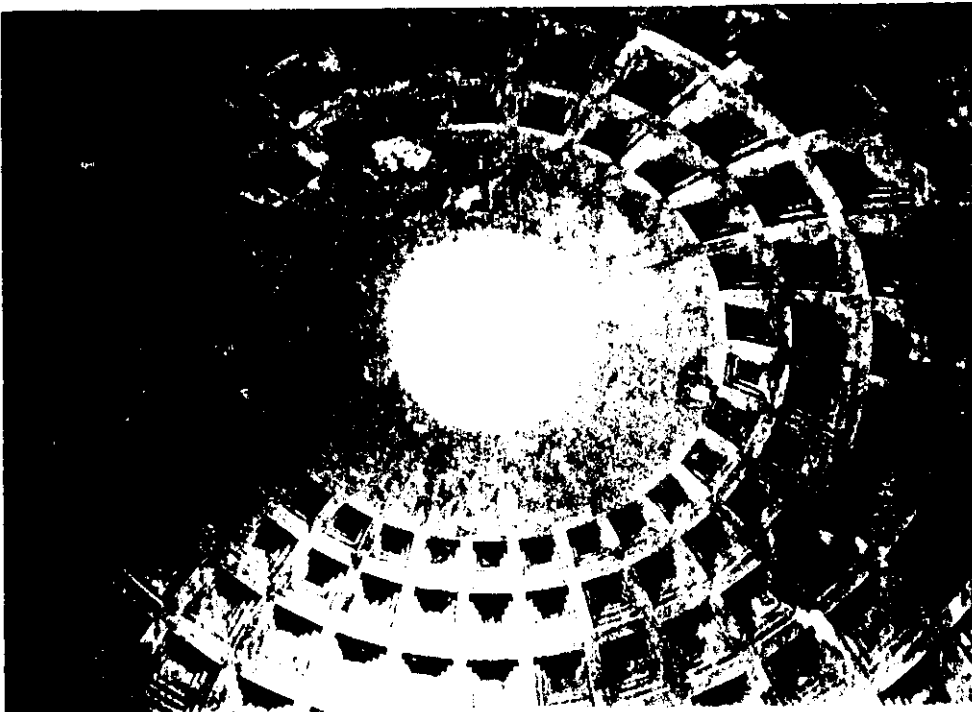
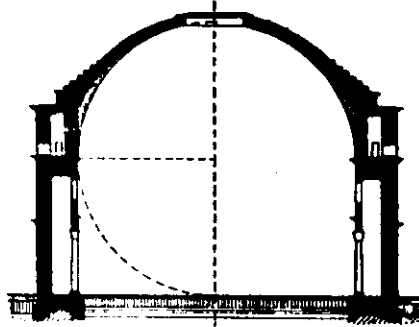
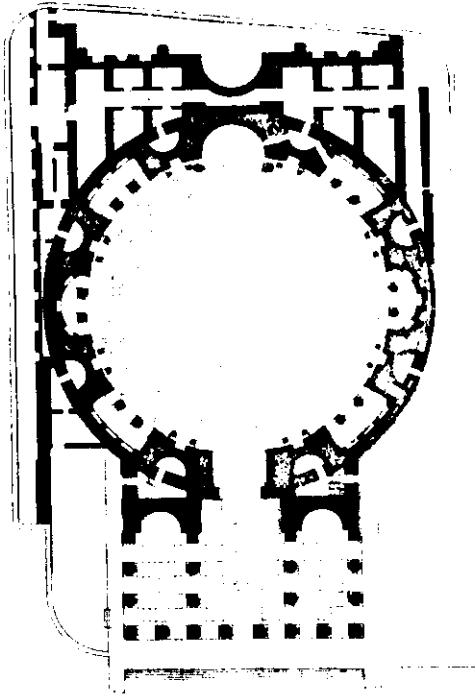

St. Front Perigueux and S. Marco

The Greek Cross plan church most immediately marks the Center with the most prominent dome over the altar in the central square.
(Images from Trachtenberg).

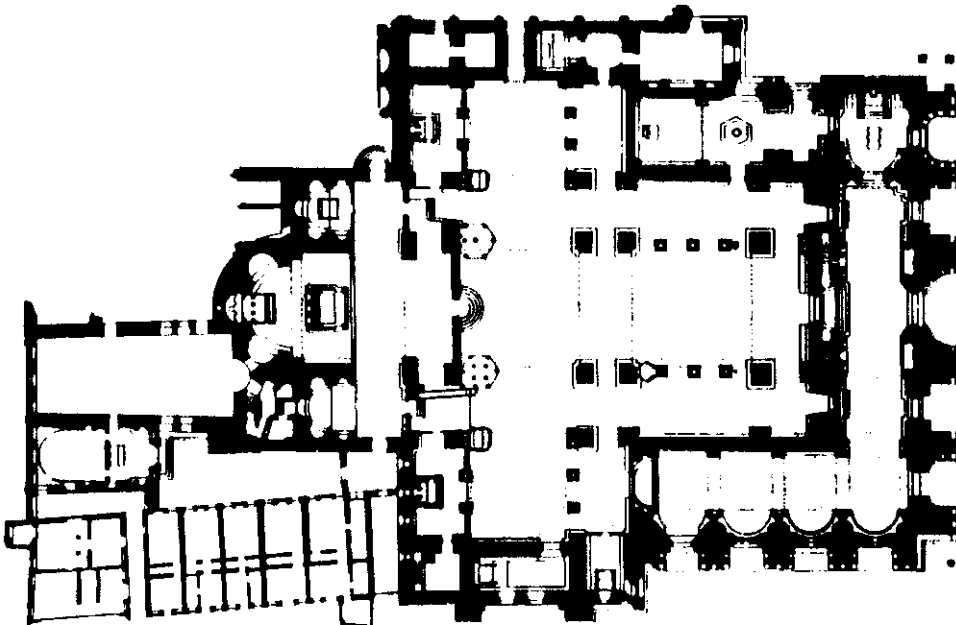
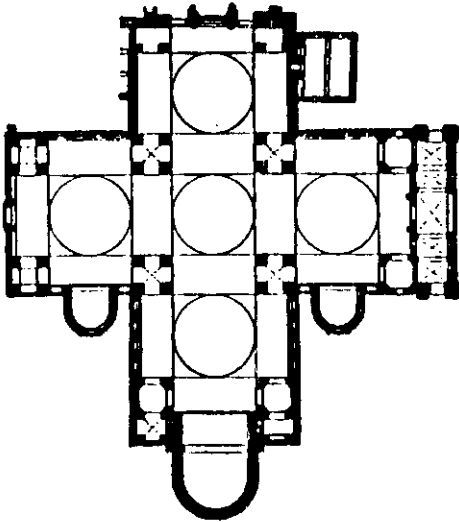

S. Vitale and Hagia Sophia

The octagon and the agglomeration of other pure forms into complex symmetries also have the ability to strongly mark the Center.
(Images from Trachtenberg).

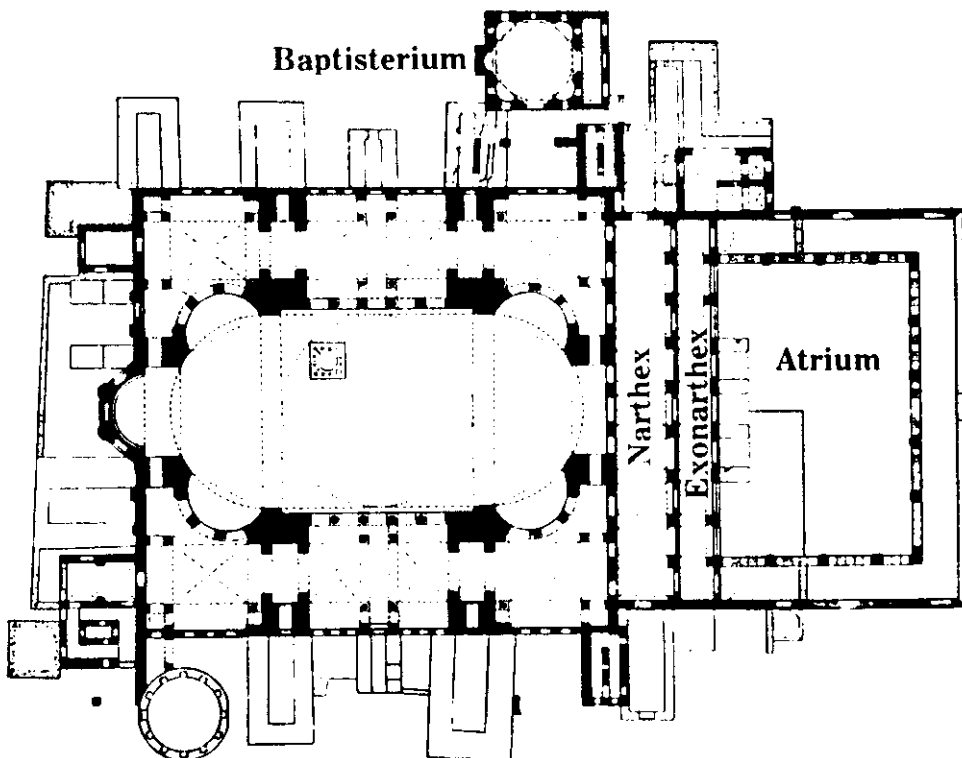
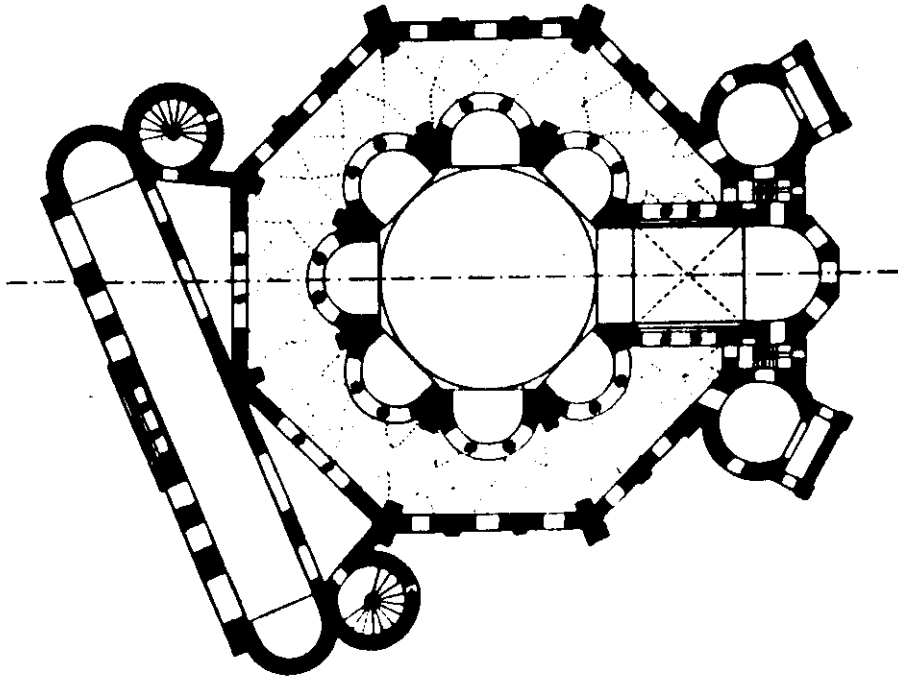

Chartres Cathedral

The Latin Cross plan conveys the symbol of the crucifixion with the nave and the transept forming a crossroads that marks the location of the altar, the heart of Christ, and also a vertical axis through the crossing. Complex symmetries and narrow vertical space cause an intense perspective view that focuses on the Center.

(Images from Trachtenberg).

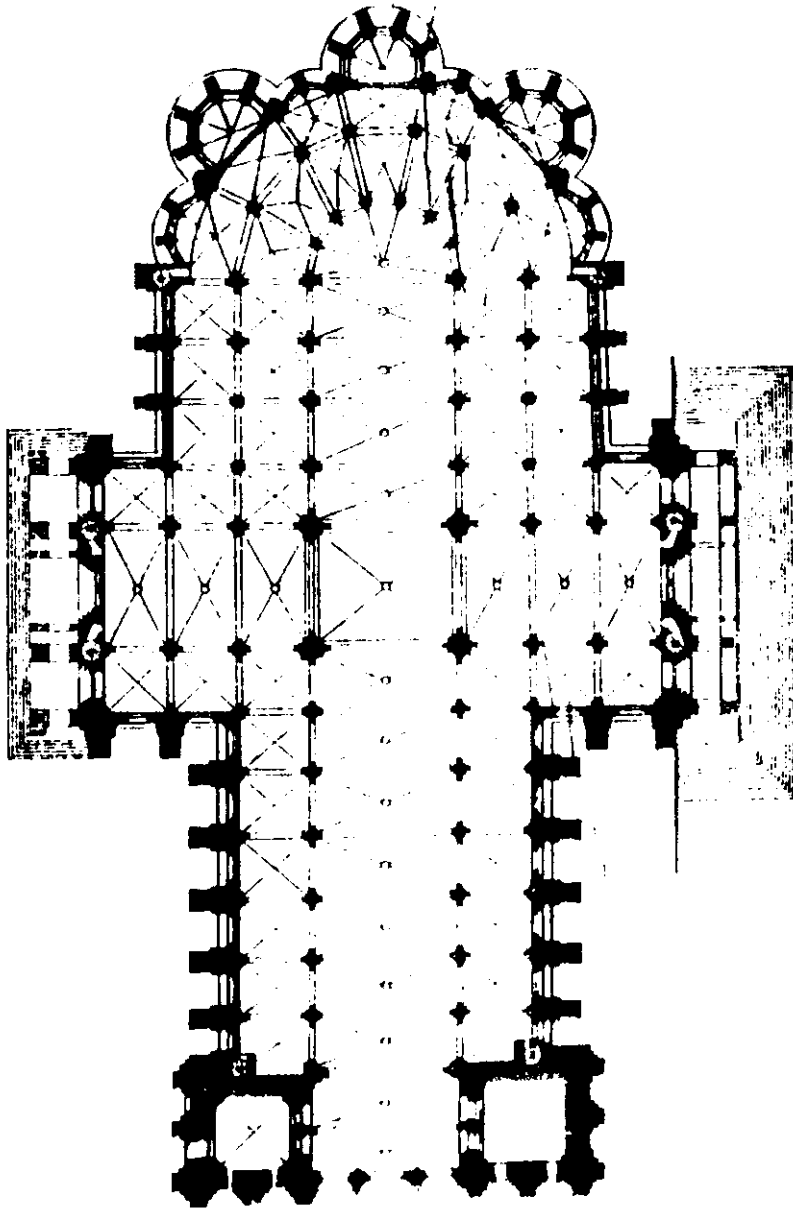

It is not by coincidence that to talk of centered architecture is to talk of sacred architecture, and thus a Theocentric architecture. Until the Nineteenth Century with the rise of rationalism, existentialism, and the Scientific and Industrial Revolutions, in most societies a theistic life, be it christian, muslim, buddhist, hindu, jewish, or some native religion, guided most aspects of life and was understood and believed by nearly everyone and occupied a prominent aspect of their lives.

Coming into the modern age of the Eighteenth Century to the present, a series of discoveries, radical ideas, innumerable wars and atrocities, and the disintegration of the Christian church (which had been a major patron of the arts and sciences) and the spread of Islam (which initiated the Renaissance), all of which served to transform and continue to change the physical and spiritual cosmologies of all cultures, nations, and religions. Naming the specific historic events that initiated each phase of the transformation would be an immense task beyond my scope, but suffice it to say that a fundamental transformational process began in the Western Civilization and grew to become global in its implications.

The world has transformed to be a place where life is much less stable, dangerous, complex, and secular with most of the most important processes of life invisible to the senses. From the invisible workings of computers and satellite telecommunications systems to microbiology and genetics, a totally different cosmological view of the world has emerged that seems incredibly different from the world we perceive with our senses. For example, Titus Burckhardt describes the cosmology of the solar system that places man as a speck on a large and complex planet, which is a speck compared to the sun, which is one among a nearly infinite number of other specks, each light years apart. This type of scaling perspective also applies to the decrease in distance and mass from the atom to the quark. A change in any of these incomprehensible and imperceptible relationships could unleash a cataclysmic of the world by disrupting the earth's orbit, devastating the ecosystem, or causing atomic explosions."

As the discoveries in science caused the changes in physical cosmology, historic events have also altered philosophy, societal values, and beliefs. Various traumas and also positive changes have caused vast transformations in all phases of life, one of which has been a secularization of life, and a rejection of symbols and the Center. An increase in atheism and a general disunity and contamination of the Christian church has contributed to the disillusionment of mainstream culture with religion and myth." The effect of this on people has been a loss or confusion of meaning and Center. The scientific and historic images of the world seemed to leave no room for theism or even humanism." Morton Kelsey writes about the onset of nihilism:

"Men are forced to search for meaning on their own. They face fear and anxiety; they have to deal aggression and hostility which cause misery within and between men. They suffer an almost undefinable heaviness, and often live with depression day in and day out which most psychiatry seems powerless to heal.... It appears that

none of these disturbances can be healed except by a sense of meaning, given by contact with that reality from which meaning originates."¹⁵

The major shift away from the Center began primarily with the Modern movement that began in the early Twentieth Century. Due to the rise of rationalism in architecture, the role of the functional program became the most important - or central - with an explicit effort to remove any ornament, symbolism, stylistic influence, or anything that was not directly related to the function.¹⁶ The attempt to communicate nothing beyond physical requirements of the architecture denied any special symbolic significance to the Center.

The use of the repetitive structural grid, while being the most practical structural system, inadvertently symbolized rationalism. The grid was infinitely repeatable in any direction, its connections were at right angles which was the most direct joint, and the size of the structure could be calculated by specific mathematical formulas that would allow for the minimum amount of material to be used in an 'honest' way. The directionless symmetry created a center line that was always movable if another bay was added, completely denying a Center; rationalism needed no single Point.¹⁶

A few decades after the scientific world abolished the system of naturalism, architecture realized that Modern, rational architecture was flawed. However, as was true with most segments of society, the void left by establishing the rational, secular, industrial world stayed even after the dogma of modernism was called into question. Modern life was either diseased or had become a disease. The airy void had now become a vacuum.¹⁶

More recently, this condition has found an expression in a non-movement called deconstruction. That this cannot even be called a movement is quite symptomatic of the directionlessness and disunity of contemporary architecture. Of this non-movement, architecture critic Charles Jencks writes:

"The sociology of alienation, ... has led to the spectre of a world populated by 'other-directed' automata, ... that is corporately conditioned and externally controlled ciphers who have lost their identities and history. And so we have the deconstructionists' abhorrence of meaning and hierarchy, sentiments shared by Tschumi, Eisenman, and Derrida, and their corresponding elevation of the Empty Man In brief it's a picture of that *beau-ideal* of the 20th Century, the Futurist and Existentialist who defines his goals and changes them without much sentiment or angst. ... The Empty Man, ... finds ... the empty centre at the heart of society, the self-contradiction of texts, the Great Void of Extinction - and this cheers him up. For what he has discovered is a religion without faith, a positive nihilism, or in Derrida's terms an affirmative Deconstruction."¹⁷

The following architects have been instrumental in representing the shift away from the Center. The architecture or paper projects shown are a few of a myriad projects. Twentieth Century architecture either loses the Center in an endless grid, forgets the concept entirely, attacks it, denies it, searches for it, or marks it as something important, but still unsure of how.

Mies van der Rohe - The Barcelona Pavilion
Abstraction and asymmetry deny a figural Center or single focus.
(Images from Trachtenberg).

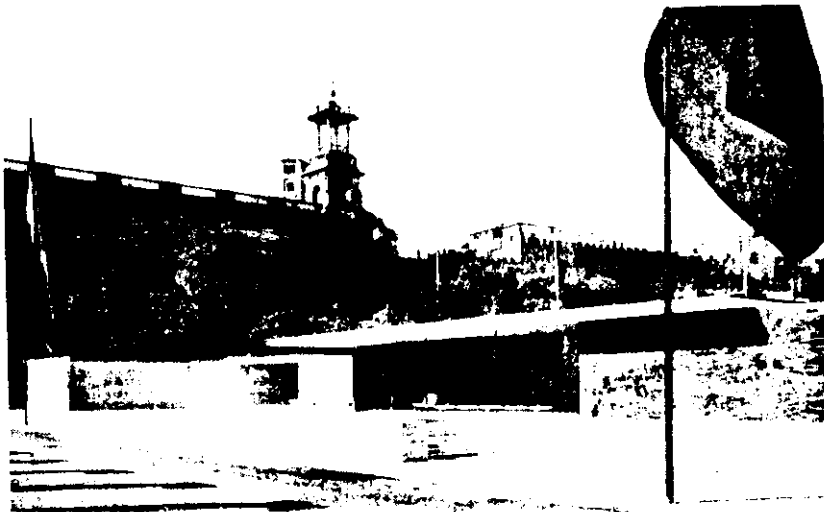
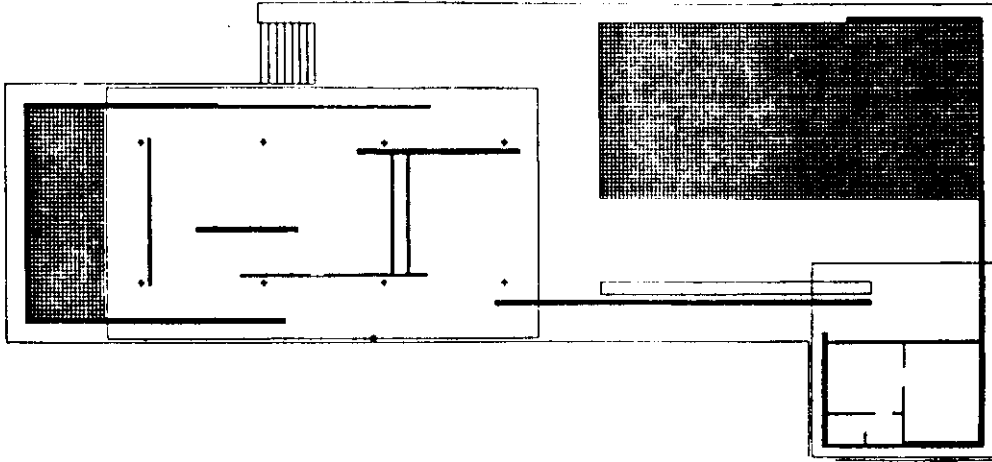

Mies van der Rohe - Seagram Building

Although not a religious structure (nor are any of the following structures), this building became the prototype for the building type that came to exemplify our culture. This building type occupied the downtown mass of modern cities (also layed out on a grid in America) and went through the same refinement process that the cathedral went through previously. The plan has only elevator banks at the center. Though a vertical axis of sorts, it has no sacred value. The building is infinitely extendable and empty. The symmetry marks nothing at the center.
(Images from Trachtenberg).

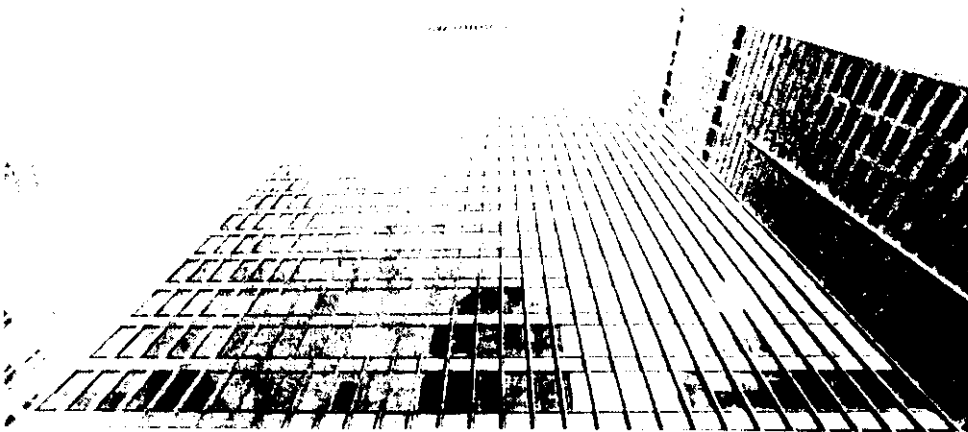
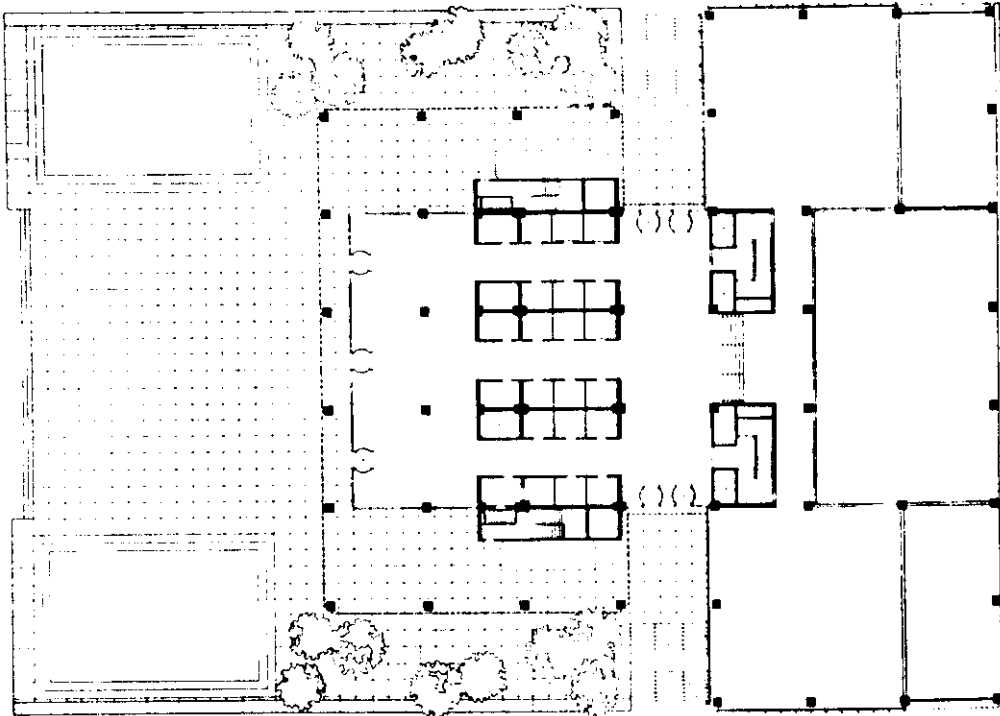

Peter Eisenman - House VI

Eisenman did a series of houses (I-X) that preceded his current work. Of particular interest in the transformation of his ideas about the void is house VI. Gavin Macrae-Gibson writes of House VI:

"Where houses I-IV express neither interest nor disinterest in centrality as a metaphor, House VI has a void center that is explicitly metaphorical. ... The central void is a place derived from and beholden to nothing but the architectural object. It is not a space that can be commanded by man or woman. ...House VI strives to represent a cultural condition. This is a condition Eisenman has identified with a sense of man's loss of control over those things both material and conceptual, to which he has given rise and the impossibility of sustaining an idealized attitude toward these artifacts and mental constructs."•

(Images from Macrae-Gibson).

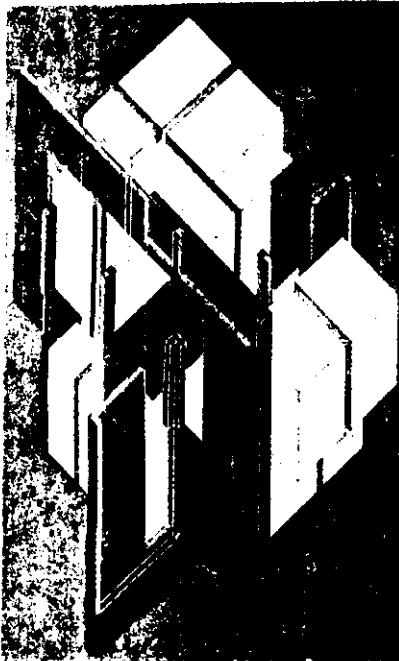
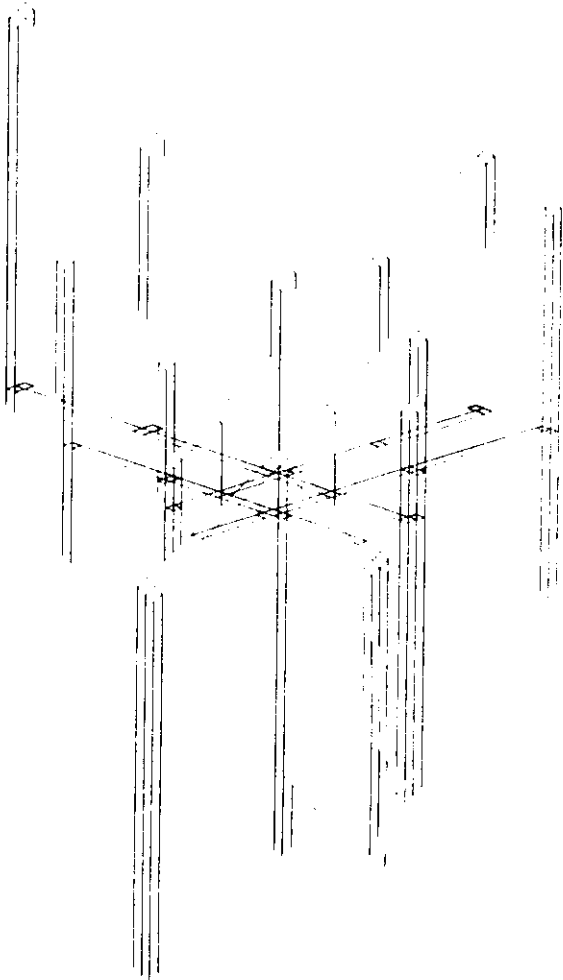

Peter Eisenman - House El Even Odd

Eisenman creates a symbol out of a square with a quarter of it removed called the el. This el has been likened to taking a bite out of a the forbidden apple in Eden." Eisenman transforms the el figure to create a complex statement about the center. Macrae-Gibson explains the el further:

"...the three-dimensional el represents the displacement suffered by man in the universe perceived by Eisenman, for in this universe man no longer commands the center (the cube), but is instead a fragment threatened by the possibility of no longer existing in it at all (the void). The three dimensional el is the sign for this displacement, halfway between nostalgia for the idealism of the past, expressed by the centrality of a platonic solid, and fear of an uncertain future, expressed by the void."

(Images from Macrae-Gibson).

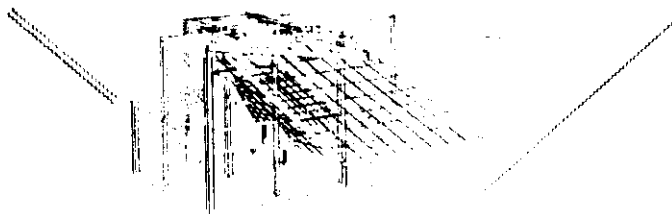
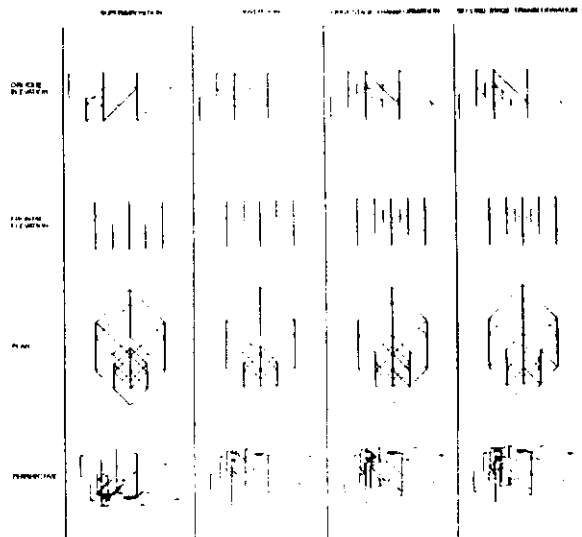

Peter Eisenman - Guardiola House

A further elaboration of the el concept into a seemingly more frantic search for the center. Charles Jencks comments further on Eisenman's thematic concerns:

[Eisenman is] "...wandering ... pushing on to further points of ennui and alienation. The Second World War, the Holocaust, the atom bomb, and any number of inseparable horrors become for him, as they do for a hero in Woody Allen's universe, the essence of Modern life, the data represented in architecture. For some people nothing has more credibility than the Great Void. ...the ultimate *differance*, Jacques Derrida's coinage for the 'difference that escapes language,' the eternal unknowable and 'otherness,' is the individual isolated from the group and now even more removed from himself in schizophrenia."²

(Images from Betsky).



Morphosis - Crawford Residence

A house that marks the Center but is unsure if not mistrustful about what occurs there. The center of the circular wall is in the bottom of a swimming pool which could be interpreted several ways. The entry of the house is on axis with this center, but looks beyond it to the ocean, which could be seen as an optimistic gesture. However, the spaces of the hoes and the guest house are pushed to a periphery that serves to de-center the house.

"The placement of the building mass and wall is intended to complicate or reverse the relationship between the center and the periphery (a deserted center with life on the periphery?)."

(Images from Davis).

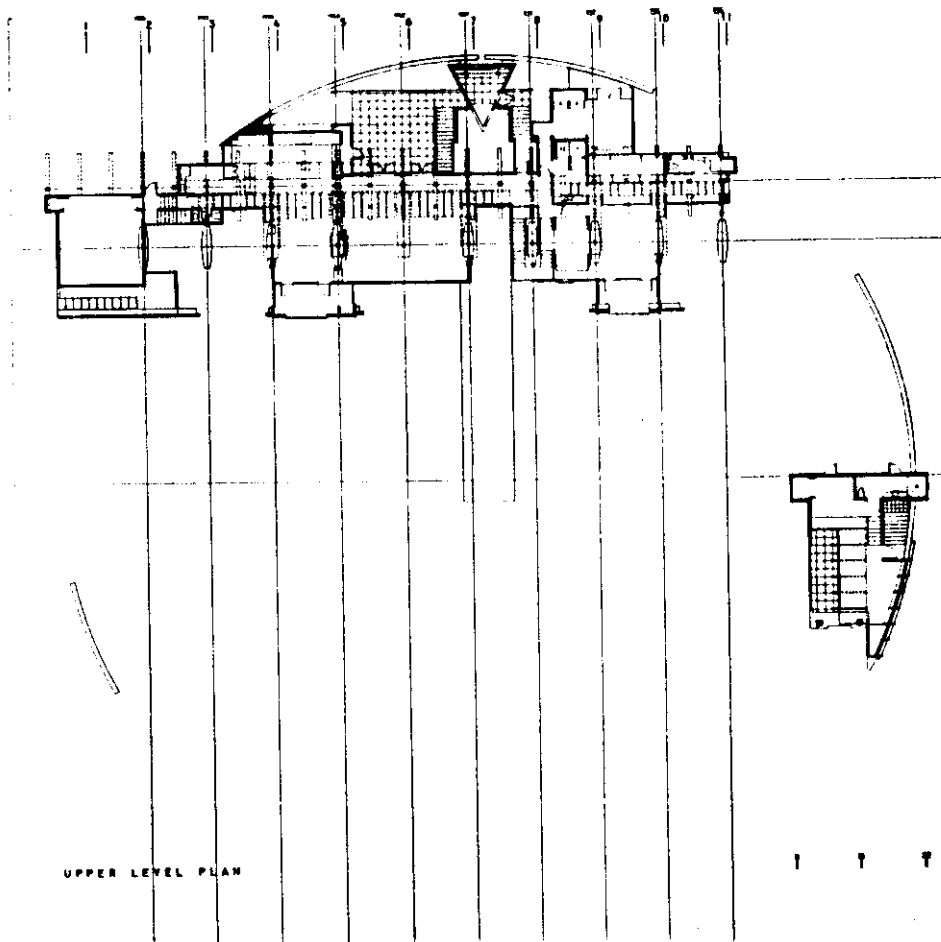

Morphosis - Sixth Street Residence

An earlier project worked with a fragmented centered space. Thom Mayne writes about the chaotic state of his context that generates his architecture:

"Today it is impossible to assess a common system of values within our pluralistic world, where reality is chaotic, unpredictable, and hence ultimately unknowable."²

"Los Angeles is in many ways prototypical of the contemporary metropolis. No longer is it possible to conceive of an impregnable city. There are no clear boundaries, only layers of mostly unperceivable infrastructure which appears as nonsequiturs."²

(Images from Davis).

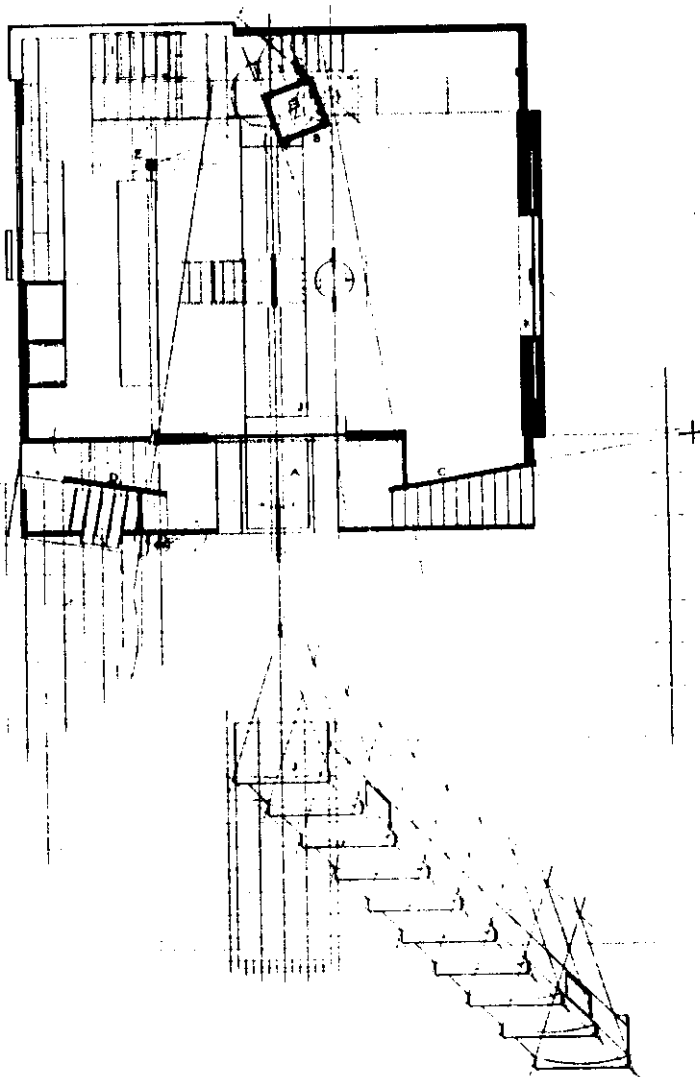

Michael Sorkin - Model City

Another example of an avoidance, fear, assault, or disbelief in the Center.

(Images from Nouver).

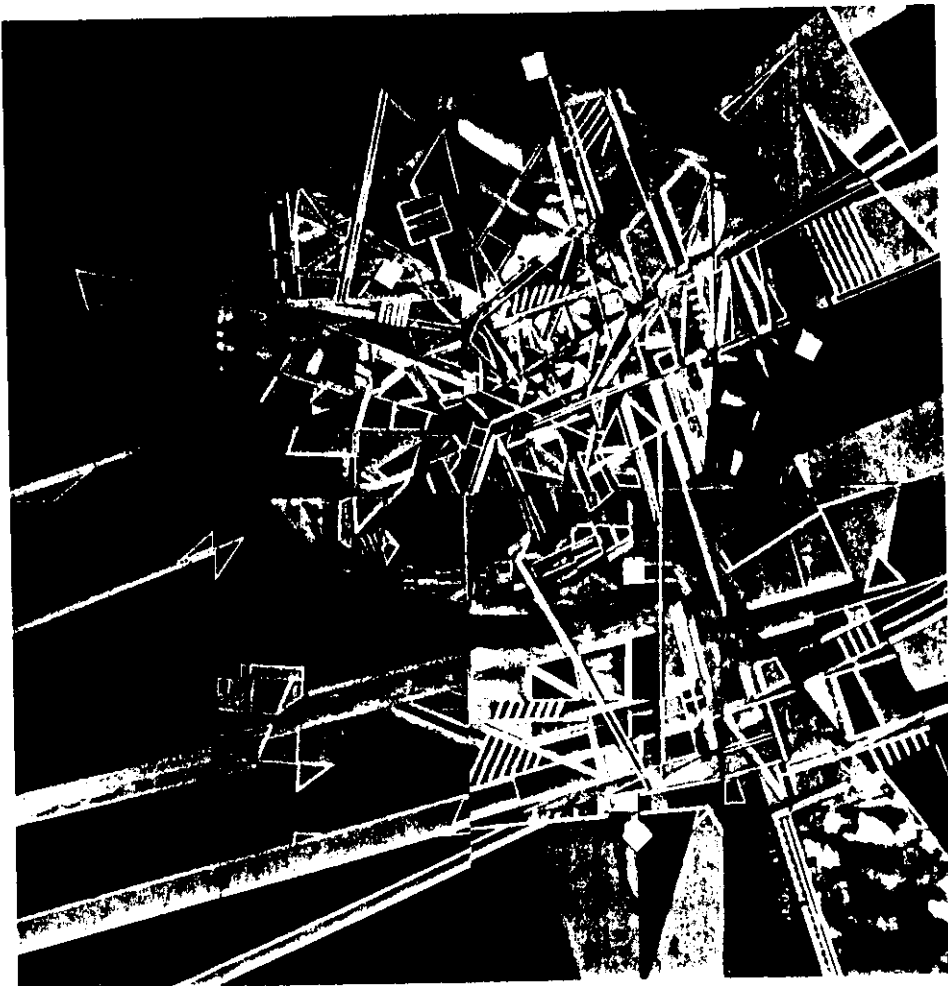

Louis Kahn - Sher - E - Bangla - Nagar, National Assembly Hall

A notable exception to the movement away from the Center is Louis Kahn. Kahn wrote mystically about Order, which was much like the concept of the Tao:

"I tried to find out what Order is. I was excited about it, and I wrote many, many words of what Order is. Every time I wrote something, I felt it wasn't quite enough. If I had covered, say, two thousand pages with just words of what Order is, I would not be satisfied with this statement. And then I stopped by not saying what it is, just saying, 'Order is.'"²⁴

(Images from Lobel).

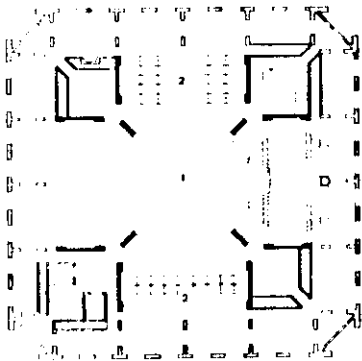

Entrance floor plan

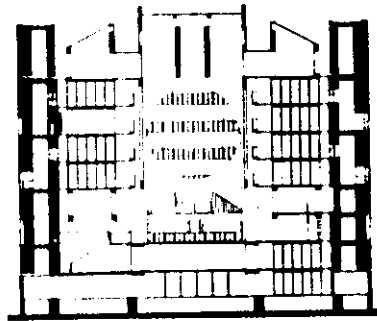

Section

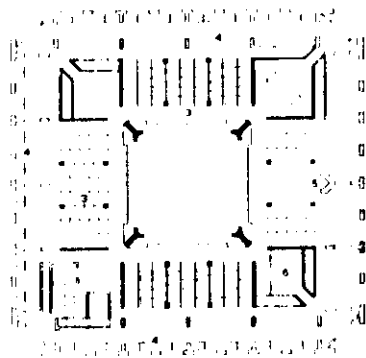

Third floor plan

1. Central hall
2. Reference and periodicals
3. Books
4. Carrels
5. Fireplace
6. Toilets

Louis Kahn - Kimbell Art Museum

"I said that all material in nature, the mountains and streams and the air and we, are made of Light which has been spent, and this crumbled mass called material casts a shadow, and the shadow belongs to light."²⁸

(Images from Lobel).

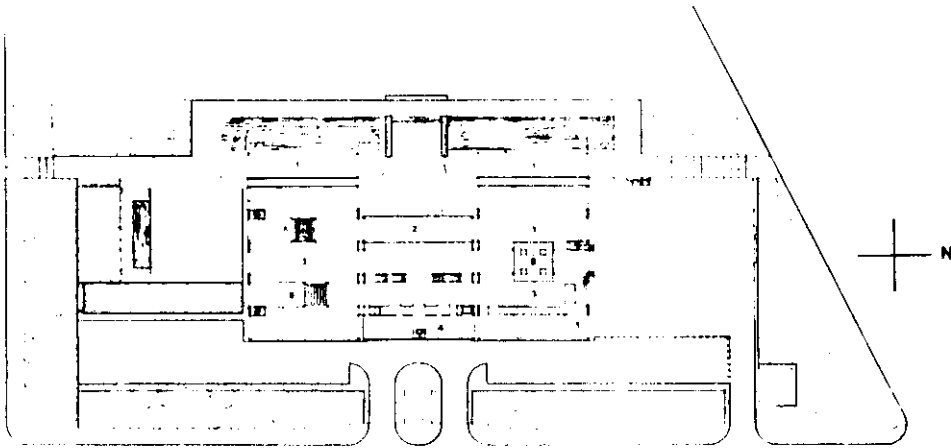

Gallery-level plan

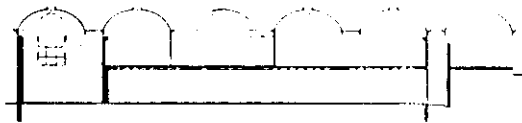

Section

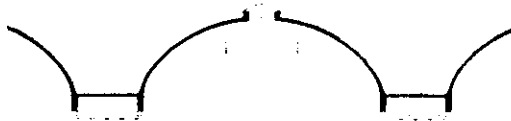

Louis Kahn - Phillips Exeter Library

"Structure is the giver of light. When I choose an order of structure that calls for column alongside column, it represents a rhythm of no light, light, no light, light, no light, light. A vault, a dome, is also a choice of a character of light."

(Images from Lobel).

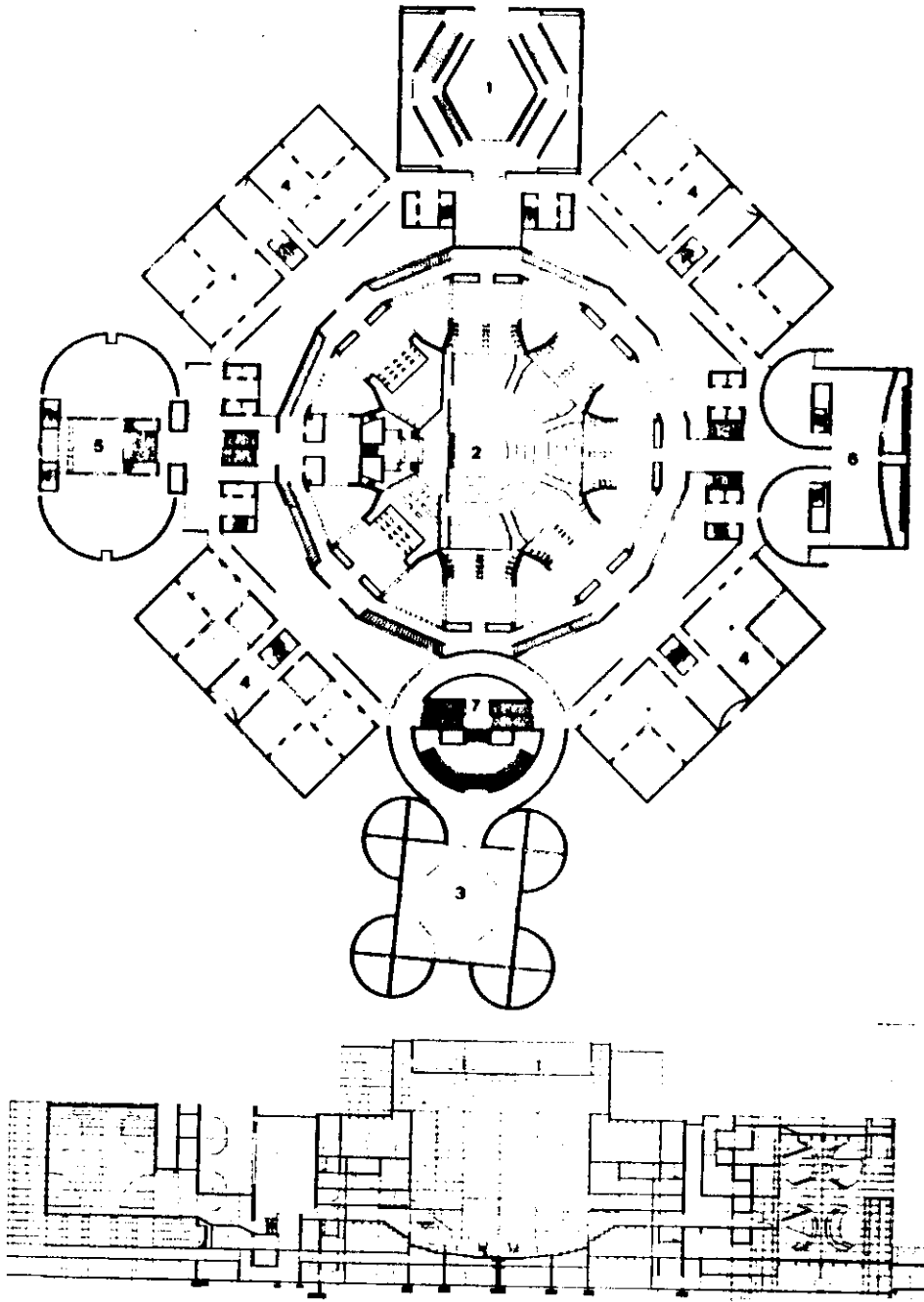

A symbol that seems to still apply to today is that of the labyrinth. The labyrinth symbolizes a struggle to reach a goal, or a state of being lost while searching for that goal. It strikes me that the goal of a labyrinth is usually in the center:

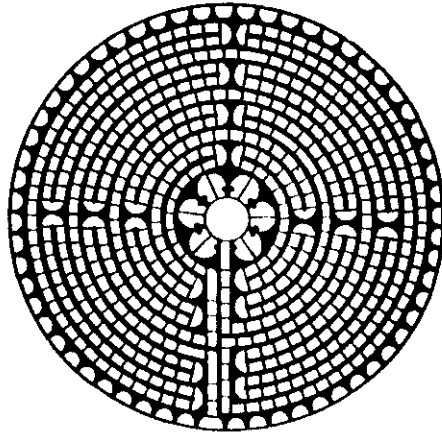

(Images from Arguelles).

Though the complexity of contemporary architecture and theory is oversimplified to call it all merely representations of a labyrinth, the general tone of much of the discourse today suggests an experimental, questioning process where boundaries are stretched. Then the very nature of the process suggests that an intense search is happening that not only manifests itself as labyrinthine architecture, but must also be a response to the searching that is felt by everyone in society for a Center. Architecture always has and always will express the values and attitudes of the society it is built within. The current searching process is, in my opinion, beautiful, natural, and something everyone will go through over and over as a continuing process of expanding life. Mircea Eliade writes of labyrinths:

"A labyrinth is usually a defense, ...built to guard a center, a treasure, a meaning. ...that symbol is the model of all existence, which passes through many ordeals in order to journey towards its own center, towards its self.... There have been occasions when I have been aware of emerging from a labyrinth, or of coming across the thread. I was feeling hopeless, oppressed, lost. Of course I didn't actually say to myself: 'I am lost in the labyrinth.' And yet, in the end, I did very much have the feeling of having emerged from a labyrinth as a victor. Everyone has that experience. But one must add that life is not just one labyrinth. The trial, the ordeal recurs."²⁷

Bibliography

- Arguelles, Jose and Miriam. Mandala. Boston: Shambhala Publications, Inc., 1972.
- Betsky, Aaron. Violated Perfection. New York: Rizzoli International Publications, 1990.
- Burckhardt, Titus. "Traditional Cosmology and Modern Science," In Mirror of the Intellect. Trans. and Ed. by William Stoddart. Albany, NY: State University of New York, 1987, pp. 17 - 67.
- Campbell, Joseph. The Power of Myth. Ed. Betty Sue Flowers. New York: Bantam Doubleday Dell Publishing Group, Inc., 1988.
- Davies, Horton and Davies, Hugh. Sacred Art in a Secular Century. Collegeville, MN: The Liturgical Press, 1978.
- Eliade, Mircea. Ordeal by Labyrinth. Chicago: The University of Chicago Press, 1982.
- Jencks, Charles. "Deconstruction: The Pleasures of Absence," Deconstruction in Architecture In Architectural Design, Profile 72. London: Academy Group, 1988, pp. 16 - 30.
- Kelsey, Morton T. Myth, History and Faith. New York: Paulist Press, 1974.
- Lobell, John. Between Silence and Light. Boston: Shambhala Publications, Inc., 1979.
- Macrae-Gibson, Gavin. The Secret Life of Buildings. Cambridge, MA: The M. I. T. Press, 1985.
- Martin, F. David. Art and the Religious Experience: The "Language of the Sacred". Cranbury, NJ: Associated University Presses, Inc., 1972.
- Mayne, Thom. "Connected Isolationism," Architecture in Transition. Ed. P. Nouver. Munich, Germany: Prestel, 1991, pp. 73 - 89.
- Mayne, Thom and Rotundi, Michael. Morphosis: A Decade of Architectural Confrontation. Spokane, WA: Cheney Cowles Museum, 1989.
- Munaro, Bruno. The Discovery of the Circle. New York: George Wittenberg, Inc., 1966.
- Trachtenberg, Marvin and Hyman, Isabelle. Architecture: From Prehistory to Post-Modernism. New York: Harry N. Abrams, Inc., 1986.

Endnotes

1. Jose Arguelles, Mandala, 1972, p.16.
2. Arguelles, p.33.
3. Bruno Munaro, The Discovery of the Circle, 1966, p. 5.
4. Arguelles, p. 12.
5. Joseph Campbell, The Power of Myth, 1988, p.214.
6. Arguelles, p.16.
7. F. David Martin, Art and the Religious Experience, 1972, p. 229.
8. Arguelles, p. 44.
9. Titus Burckhardt, "On Cosmology and Modern Science," Mirror of the Intellect, 1987, pp. 31-33.
10. Burckhardt, p. 33.
11. Horton Davies, Sacred Art in a Secular Century, 1978, p. 3.
12. Morton Kelsey, Myth, History and Faith, 1974, p.8.
13. Kelsey, p. 10.
14. John Lobel, Between Silence and Light, 1979, p.61.
15. Lobel p. 62.
16. Lobel p. 62.
17. Charles Jencks, "The Pleasures of Absence," Deconstruction in Architecture, 1988, p. 25.
18. Gavin Macrae-Gibson, The Secret Life of Buildings, 1985, p. 30-34.
19. Macrae-Gibson, p. 35.
20. Jencks, p. 17.
21. Thom Mayne and Michael Rotundi, Morphosis, 1988, p. 16.
22. Thom Mayne, "Connected Isolation," Architecture in Transition, 1991, p. 73.
23. Mayne, "Connected....," p. 74.
24. Lobel, p. 18.

25. Lobel, p. 22.

26. Lobel, p. 34.

27. Mircea Eliade, Ordeal by Labyrinth, 1982, p.185.

The following are selected sketches from the design process.

Appendix III.

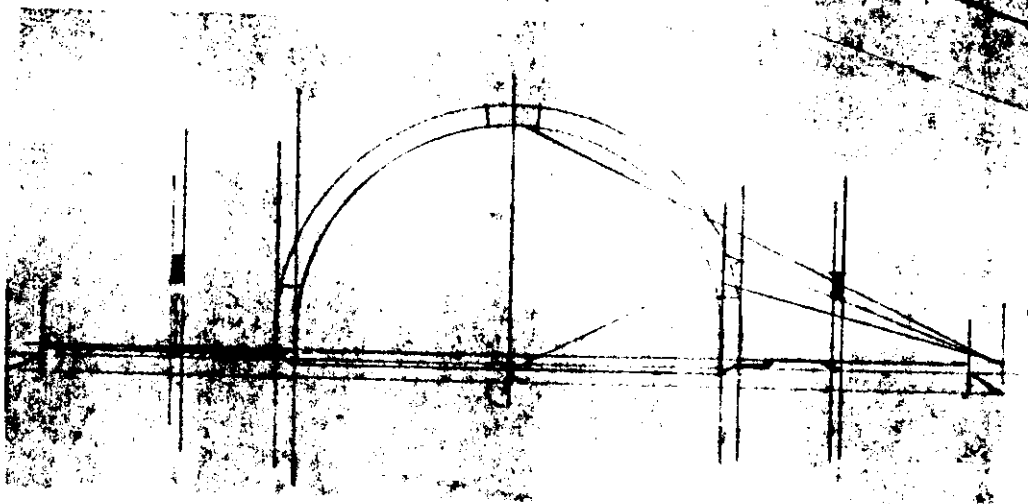
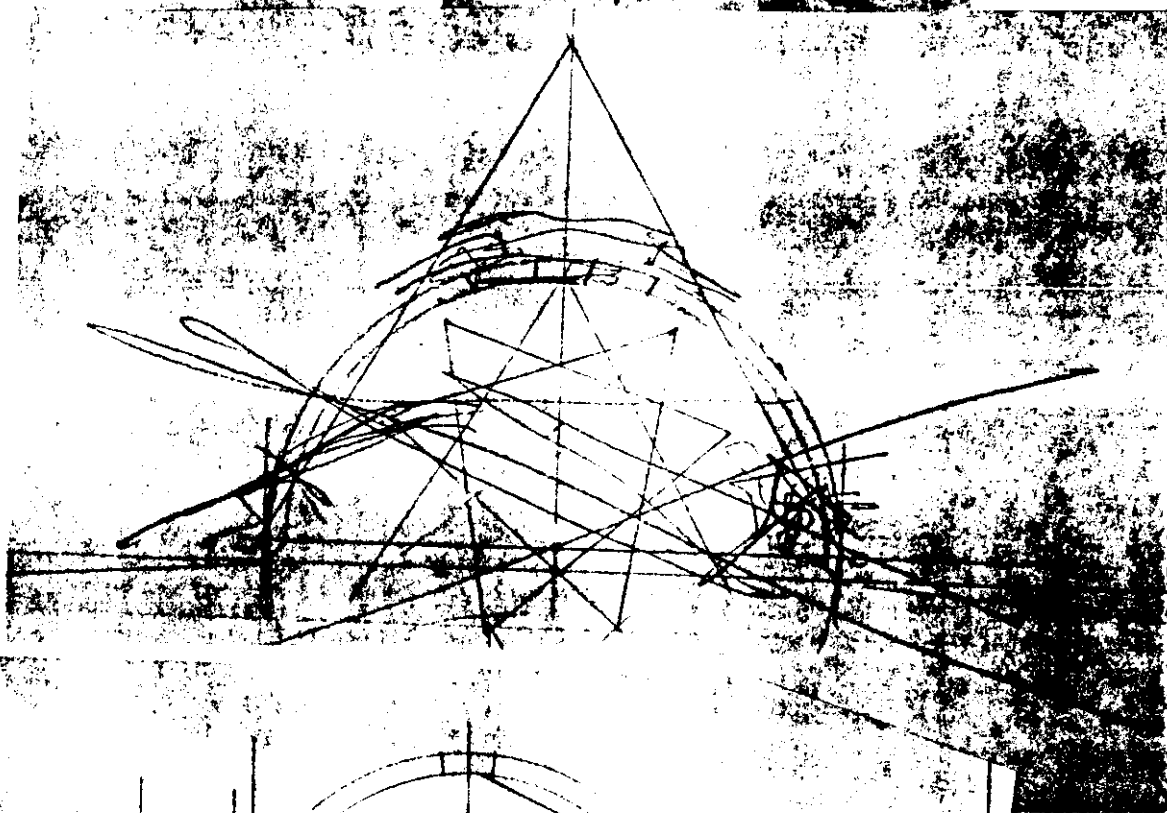
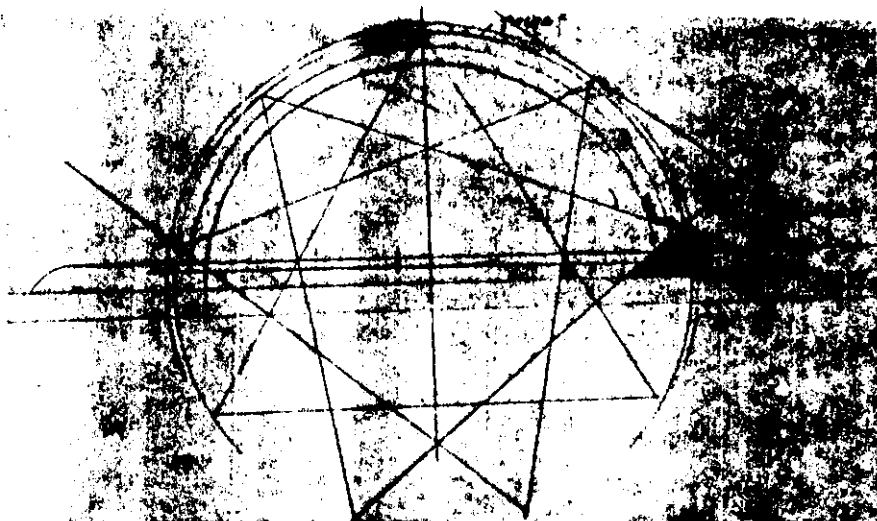

eighty-eight

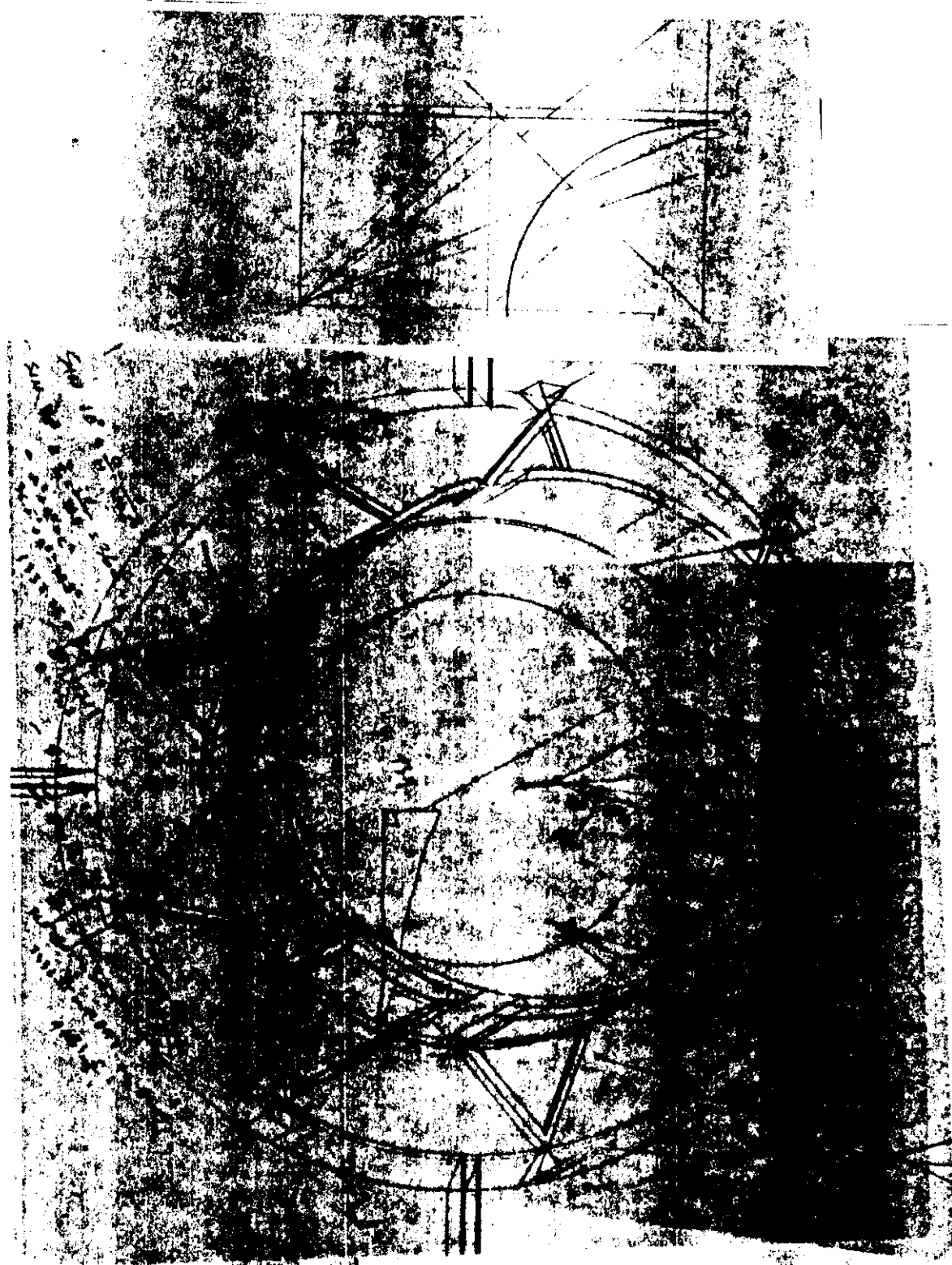
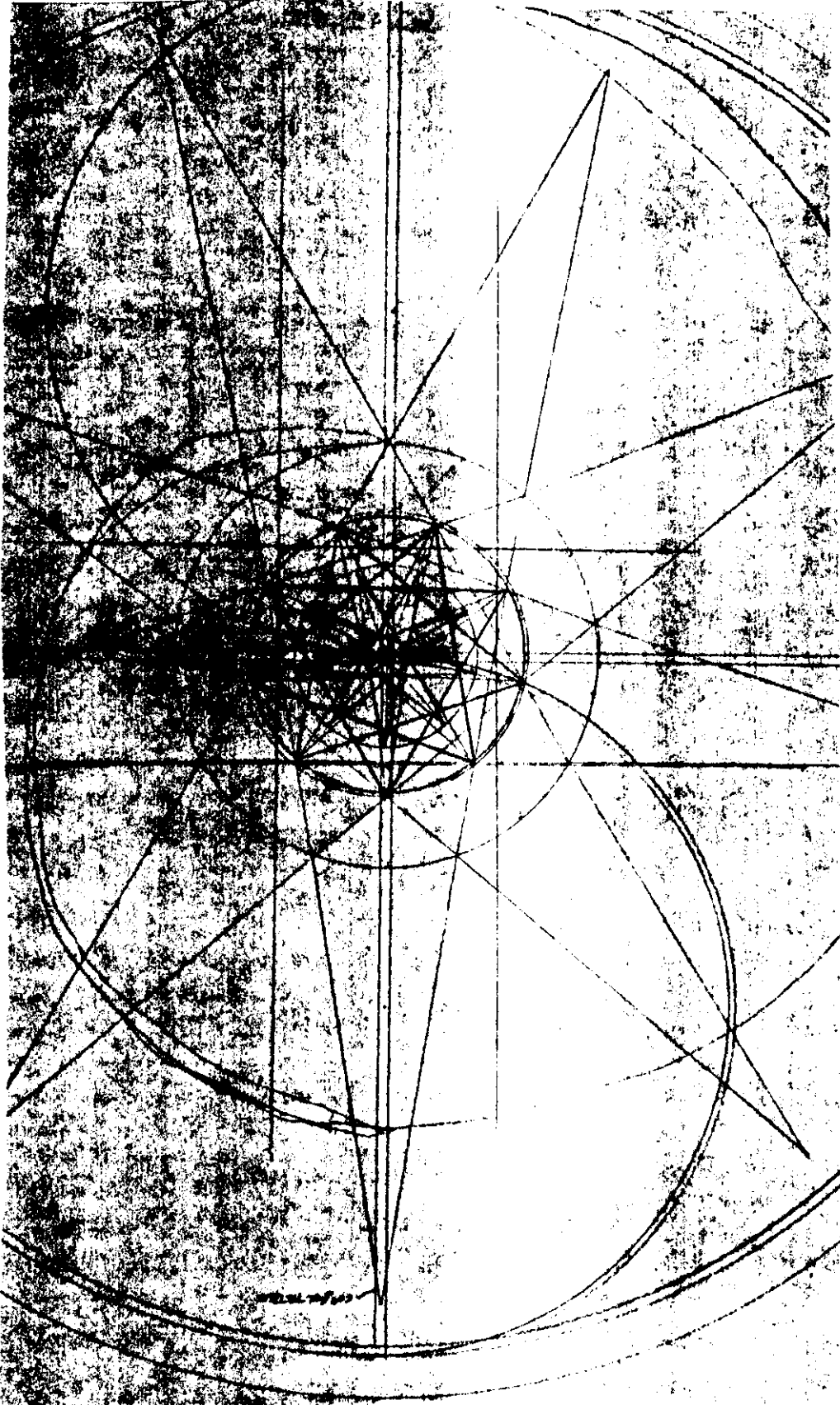

Fig 2



eighty-nine



ninety